

# Service Manual



## PQA300 Picture Quality Analysis System

**071-0914-00**

This document applies to firmware version 1.00 and above.

### **Warning**

The servicing instructions are for use by qualified personnel only. To avoid personal injury, do not perform any servicing unless you are qualified to do so. Refer to all safety summaries prior to performing service.

**[www.tektronix.com](http://www.tektronix.com)**

Copyright © Tektronix, Inc. All rights reserved.

Tektronix products are covered by U.S. and foreign patents, issued and pending. Information in this publication supercedes that in all previously published material. Specifications and price change privileges reserved.

JNDmetrix is a trademark of Sarnoff Corporation

Tektronix, Inc., P.O. Box 500, Beaverton, OR 97077

TEKTRONIX and TEK are registered trademarks of Tektronix, Inc.

## WARRANTY

Tektronix warrants that the products that it manufactures and sells will be free from defects in materials and workmanship for a period of one (1) year from the date of shipment. If a product proves defective during this warranty period, Tektronix, at its option, either will repair the defective product without charge for parts and labor, or will provide a replacement in exchange for the defective product.

In order to obtain service under this warranty, Customer must notify Tektronix of the defect before the expiration of the warranty period and make suitable arrangements for the performance of service. Customer shall be responsible for packaging and shipping the defective product to the service center designated by Tektronix, with shipping charges prepaid. Tektronix shall pay for the return of the product to Customer if the shipment is to a location within the country in which the Tektronix service center is located. Customer shall be responsible for paying all shipping charges, duties, taxes, and any other charges for products returned to any other locations.

This warranty shall not apply to any defect, failure or damage caused by improper use or improper or inadequate maintenance and care. Tektronix shall not be obligated to furnish service under this warranty a) to repair damage resulting from attempts by personnel other than Tektronix representatives to install, repair or service the product; b) to repair damage resulting from improper use or connection to incompatible equipment; c) to repair any damage or malfunction caused by the use of non-Tektronix supplies; or d) to service a product that has been modified or integrated with other products when the effect of such modification or integration increases the time or difficulty of servicing the product.

**THIS WARRANTY IS GIVEN BY TEKTRONIX IN LIEU OF ANY OTHER WARRANTIES, EXPRESS OR IMPLIED. TEKTRONIX AND ITS VENDORS DISCLAIM ANY IMPLIED WARRANTIES OF MERCHANTABILITY OR FITNESS FOR A PARTICULAR PURPOSE. TEKTRONIX' RESPONSIBILITY TO REPAIR OR REPLACE DEFECTIVE PRODUCTS IS THE SOLE AND EXCLUSIVE REMEDY PROVIDED TO THE CUSTOMER FOR BREACH OF THIS WARRANTY. TEKTRONIX AND ITS VENDORS WILL NOT BE LIABLE FOR ANY INDIRECT, SPECIAL, INCIDENTAL, OR CONSEQUENTIAL DAMAGES IRRESPECTIVE OF WHETHER TEKTRONIX OR THE VENDOR HAS ADVANCE NOTICE OF THE POSSIBILITY OF SUCH DAMAGES.**



# Table of Contents

<b>General Safety Summary</b> .....	<b>xi</b>
<b>Service Safety Summary</b> .....	<b>xiii</b>
<b>Preface</b> .....	<b>xv</b>
Related Manuals .....	xvi
Manual Conventions .....	xvi
<b>Introduction</b> .....	<b>xvii</b>
Before You Begin .....	xvii
Service Strategy .....	xvii
Tektronix Service Offerings .....	xviii
Warranty Repair Service .....	xviii
Repair Service .....	xviii
Self Service .....	xviii
Contacting Tektronix .....	xix

## Specifications

Product Description .....	1-1
Operating Features .....	1-2
Specification Tables .....	1-4
Performance Conditions .....	1-4
Hardware Specifications .....	1-5
System Components .....	1-9
Power Specifications .....	1-12
Mechanical (Physical) Characteristics .....	1-12
Environmental Characteristics .....	1-13
Certification and Compliances .....	1-14

## Operating Information

Installation .....	2-1
First Time Operation .....	2-5
First Time Power On .....	2-5
Preference Preset .....	2-6
Virtual Front Panel Controls, Indicators, and Display .....	2-10
Soft Key Controls .....	2-11
Text Editing and Keyboard Controls .....	2-12
Display Behavior .....	2-12
Configuration Menus .....	2-13
Other Soft Key Choices .....	2-13
Messages and Prompts .....	2-23

## Theory of Operation

Functional Operation .....	3-1
Hardware Implementation .....	3-2
Data Flow .....	3-3
Functional Block Overview .....	3-4

Composite Generator Configurations .....	3-6
Composite Analyzer Configuration .....	3-8
DSP System Operation .....	3-8
Serial Digital I/O Block Description .....	3-9
DSP Block Description .....	3-11
PCI Bus Interface .....	3-12
Boot ROM .....	3-12
Composite Decoder .....	3-12
Input .....	3-12
Calibration Generator .....	3-13
Sync Stripper .....	3-13
A/D Converters .....	3-14
Decoder .....	3-14
FPGA .....	3-14
Color Lock .....	3-14
Parallel to Serial Converter .....	3-14
PCI Interface .....	3-14
Composite Encoder .....	3-15
Serial Receiver .....	3-15
Encoder .....	3-15
Genlock .....	3-15
Serial Black Burst .....	3-16
PCI Interface .....	3-16

## Performance Verification

Test Interval .....	4-1
Prerequisites .....	4-1
Equipment Required .....	4-1
Procedure .....	4-3
Load the Impaired Test Sequences .....	4-4
Set Up the PQA300 System for Serial Digital Testing .....	4-5
Unimpaired Sequence Test .....	4-7
Impaired Sequence Test .....	4-8
Check Analyzer DSP 601 Out Signal .....	4-10
Analyzer 601 Out Amplitude .....	4-12
Check Analyzer Channel A Out Loop Through Amplitude .....	4-16
Check Generator 601 Output .....	4-18
Check Generator Main Loop Through .....	4-19
Analyzer and Generator Channel B Out Loop Through Connectors .....	4-20
Option 1 Performance Verification .....	4-21

Run Encoder and Decoder Diagnostics .....	4-21
Set Up the PQA300 System for Composite Video Testing .....	4-24
Composite Sequence Test Using a 601 Ref .....	4-26
Composite Sequence Test Using a De-embedded Ref .....	4-27
Composite Impaired Sequence Test .....	4-29
S-Video Verification .....	4-30
Format Verification .....	4-32
Decoder 601 Out Amplitude .....	4-33
Check Encoder Output Amplitude Accuracy .....	4-35
Check Encoder Serial Black Out Genlock .....	4-41
Check the DSP 27 MHz Clock Frequency .....	4-43
Test Equipment Setup .....	4-43

## Adjustment Procedures

Equipment Required .....	5-1
DSP 27 MHz Oscillator Frequency Adjustment .....	5-1
Test Equipment Setup .....	5-2
Encoder Auto Cal .....	5-4
Check the Encoder Reference Voltage .....	5-4
Run the Encoder Auto Calibration Routine .....	5-6
Decoder Board Adjustments .....	5-7
Adjust Luma Gain .....	5-7
Adjust Chroma Gain .....	5-10
Run the Decoder Diagnostic .....	5-10

## Maintenance

Preparation .....	6-1
Handling Static-Sensitive Components .....	6-1
Cleaning and Inspection .....	6-2
Removal and Replacement Instructions .....	6-3
Replaceable Modules .....	6-3
Recommended Tools .....	6-4
Removing the Bezel Trim Ring .....	6-4
Removing the Cabinet .....	6-4
Replacing the PQA300 Cabinet .....	6-6
Replacing the Bezel Trim Ring .....	6-7
Application Modules .....	6-8
Removing a Plug-In Module .....	6-8
Reinstalling a Plug-In Module .....	6-9
Mainframe Modules .....	6-9
Removing the Interface Circuit Board Cover .....	6-9

Reinstalling the Front Panel Interface Circuit Board Cover .....	6-10
Removing the Blank Key Pad Assembly .....	6-11
Replacing the Key Pad Assembly .....	6-12
Removing the Flat Panel Display .....	6-12
Reinstalling the Flat Panel Display .....	6-12
Removing the Key Pad Assembly .....	6-13
Replacing the Key Pad Assembly .....	6-14
Removing the CD and Floppy Disk Drive Assembly .....	6-15
Removing and Replacing the CDROM Drive .....	6-16
Removing and Replacing the Floppy Disk Drive .....	6-17
Reinstalling the CD and Floppy Disk Drive Assembly .....	6-18
Speaker Removal .....	6-19
Speaker Replacement .....	6-20
Removing and Replacing the Dual SCSI Hard Disk Drives .....	6-21
Power Supply Removal and Replacement .....	6-22
Controller Board Removal and Replacement .....	6-24
Controller I/O Board Removal and Replacement .....	6-26
Interface Board Removal and Replacement .....	6-32
Backplane Circuit Board Removal and Replacement .....	6-36
CPU Jumper Settings .....	6-37
Repacking for Shipment .....	6-40
Obtaining Replacement Packaging .....	6-40
Repackaging Instructions .....	6-41

## Options

Option 01 Composite Video .....	7-1
Option LC Display .....	7-2

## Replaceable Parts

Parts Ordering Information .....	8-1
Module Servicing .....	8-1
Module Exchange .....	8-1
Module Repair and Return .....	8-1
New Modules .....	8-1
Using the Replaceable Parts List .....	8-2
Abbreviations .....	8-2
Mfr. Code to Manufacturer Cross Index .....	8-2

## Appendices

<b>Appendix A: Software Repair .....</b>	<b>A-1</b>
If an Application Locks .....	A-1
Creating and Using an Emergency Repair Disk .....	A-1
Creating an Emergency Repair Disk .....	A-2
Using the Emergency Repair Disk .....	A-3
Reinstalling the PQA300 Picture Quality Analysis System Software .....	A-4
Installing the PQA300 Application Program .....	A-4
Standard Instrument Encoder and Decoder Driver .....	A-4
Installing the Generator and Reference Sequences .....	A-5
<b>Appendix B: PQA300 Directories and Files .....</b>	<b>B-1</b>
<b>Appendix C: Video Test Sequences .....</b>	<b>C-1</b>



# List of Figures

<b>Figure 1-1: Components of the PQA300 Picture Quality Analysis System</b> .....	<b>1-1</b>
<b>Figure 2-1: PQA300 system rear panel</b> .....	<b>2-2</b>
<b>Figure 2-2: On/Stby switch</b> .....	<b>2-5</b>
<b>Figure 2-3: Virtual front panel with soft key menus</b> .....	<b>2-8</b>
<b>Figure 2-4: Supporting functions under the Other soft key</b> .....	<b>2-11</b>
<b>Figure 2-5: Working directory selection screen</b> .....	<b>2-12</b>
<b>Figure 2-6: File Operations menu under the Other soft key</b> .....	<b>2-13</b>
<b>Figure 2-7: Select Network Drive menu</b> .....	<b>2-14</b>
<b>Figure 2-8: The Save As menu for saving results text files</b> .....	<b>2-15</b>
<b>Figure 2-9: The network selection menu for choosing the location to store results text files</b> .....	<b>2-15</b>
<b>Figure 2-10: Display settings controls</b> .....	<b>2-16</b>
<b>Figure 2-11: Hardware settings menu</b> .....	<b>2-17</b>
<b>Figure 2-12: Encoder/Decoder diagnostics and Encoder Auto-Cal</b> .....	<b>2-18</b>
<b>Figure 2-13: Help system contents screen</b> .....	<b>2-19</b>
<b>Figure 2-14: Progress indicator shown across the bottom of the display</b> .....	<b>2-19</b>
<b>Figure 3-1: Test setup for direct measurement of system fidelity</b> .....	<b>3-1</b>
<b>Figure 3-2: Functional operation diagram</b> .....	<b>3-2</b>
<b>Figure 3-3: PQA300 Picture Quality Analysis System block diagram with encoder/decoder option</b> .....	<b>3-5</b>
<b>Figure 3-4: Composite generator with external analog reference</b> ..	<b>3-6</b>
<b>Figure 3-5: Composite generator free-run mode</b> .....	<b>3-7</b>
<b>Figure 3-6: Composite analyzer block diagram</b> .....	<b>3-8</b>
<b>Figure 3-7: Digital signal processor module I/O section simplified block diagram</b> .....	<b>3-9</b>
<b>Figure 3-8: Digital signal processor module DSP section simplified block diagram</b> .....	<b>3-11</b>
<b>Figure 3-9: Decoder simplified block diagram</b> .....	<b>3-13</b>
<b>Figure 3-10: Encoder simplified block diagram</b> .....	<b>3-16</b>

<b>Figure 4-1: On/Stby switch</b> .....	<b>4-3</b>
<b>Figure 4-2: Initial connections for the functional check</b> .....	<b>4-5</b>
<b>Figure 4-3: Connection for analyzer 601 Out check</b> .....	<b>4-11</b>
<b>Figure 4-4: CH 1 high amplitude</b> .....	<b>4-14</b>
<b>Figure 4-5: CH 1 low amplitude</b> .....	<b>4-14</b>
<b>Figure 4-6: CH 1 fall time</b> .....	<b>4-15</b>
<b>Figure 4-7: CH 1 rise time</b> .....	<b>4-16</b>
<b>Figure 4-8: Connection for analyzer Channel A Out loop through check</b> .....	<b>4-17</b>
<b>Figure 4-9: Connection for generator output check</b> .....	<b>4-18</b>
<b>Figure 4-10: Connections for the Generator Channel A Out loop through check</b> .....	<b>4-19</b>
<b>Figure 4-11: Hardware settings menu</b> .....	<b>4-21</b>
<b>Figure 4-12: Encoder/Decoder diagnostics and Encoder Auto-Cal</b> .....	<b>4-22</b>
<b>Figure 4-13: Connections for the encoder and decoder functional check</b> .....	<b>4-24</b>
<b>Figure 4-14: Decoder Configuration menu Notch processing selection</b> .....	<b>4-27</b>
<b>Figure 4-15: Decoder Configuration menu for S-Video</b> .....	<b>4-31</b>
<b>Figure 4-16: Connections for the decoder 601 output check</b> .....	<b>4-33</b>
<b>Figure 4-17: Encoder Configuration menu</b> .....	<b>4-34</b>
<b>Figure 4-18: Hardware settings menu</b> .....	<b>4-36</b>
<b>Figure 4-19: Encoder/Decoder diagnostics and Encoder Auto-Cal</b> .....	<b>4-36</b>
<b>Figure 4-20: Setup for Composite video luma (Y) and chroma (C) gain and offset</b> .....	<b>4-37</b>
<b>Figure 4-21: PQA encoder/decoder dialog box</b> .....	<b>4-38</b>
<b>Figure 4-22: Encoder diagnostics selection menu</b> .....	<b>4-39</b>
<b>Figure 4-23: Setup for S-Video luma (Y) and chroma (C) gain and offset</b> .....	<b>4-40</b>
<b>Figure 4-24: Connections for Serial Black Out and Genlock check</b> .....	<b>4-42</b>
<b>Figure 4-25: Oscillator test point for frequency check</b> .....	<b>4-44</b>
<b>Figure 5-1: 27 MHz clock test point for frequency adjustment</b> ....	<b>5-3</b>
<b>Figure 5-2: Locating the decoder and encoder circuit boards</b> .....	<b>5-5</b>
<b>Figure 5-3: Location of TP75, the 1.250 V encoder auto-cal reference test point</b> .....	<b>5-5</b>
<b>Figure 5-4: Hardware settings menu</b> .....	<b>5-6</b>
<b>Figure 5-5: Encoder/Decoder diagnostics and Encoder Auto-Cal</b> ..	<b>5-7</b>

<b>Figure 5-6: Decoder board LED indicator locations</b> .....	<b>5-8</b>
<b>Figure 5-7: Decoder board adjustment locations</b> .....	<b>5-9</b>
<b>Figure 6-1: Right side handle screws</b> .....	<b>6-5</b>
<b>Figure 6-2: Rear panel feet removal</b> .....	<b>6-6</b>
<b>Figure 6-3: Circuit board retaining plate</b> .....	<b>6-8</b>
<b>Figure 6-4: Front panel circuit board cover removal</b> .....	<b>6-10</b>
<b>Figure 6-5: Blank key pad assembly removal</b> .....	<b>6-11</b>
<b>Figure 6-6: Flat panel display removal</b> .....	<b>6-13</b>
<b>Figure 6-7: Key pad assembly removal</b> .....	<b>6-14</b>
<b>Figure 6-8: Front panel interface circuit board connectors</b> .....	<b>6-15</b>
<b>Figure 6-9: Chassis screw locations for CD drive</b> .....	<b>6-16</b>
<b>Figure 6-10: Chassis screw locations for the floppy disk drive</b> ....	<b>6-17</b>
<b>Figure 6-11: Floppy disk drive and CD audio connector installation</b> .....	<b>6-19</b>
<b>Figure 6-12: Speaker installation and fan locations</b> .....	<b>6-20</b>
<b>Figure 6-13: Power supply large and small screws locations</b> .....	<b>6-23</b>
<b>Figure 6-14: Controller board orientation and screw locations</b> ....	<b>6-25</b>
<b>Figure 6-15: SCSI ribbon cable connection location</b> .....	<b>6-27</b>
<b>Figure 6-16: Insert I/O board into slot 12</b> .....	<b>6-28</b>
<b>Figure 6-17: Installing the I/O circuit board</b> .....	<b>6-29</b>
<b>Figure 6-18: I/O to controller board top interconnections</b> .....	<b>6-30</b>
<b>Figure 6-19: I/O to controller board bottom interconnections</b> .....	<b>6-31</b>
<b>Figure 6-20: Top connection to controller board</b> .....	<b>6-31</b>
<b>Figure 6-21: Location of J220 connections and wiring orientation</b> .....	<b>6-32</b>
<b>Figure 6-22: Front panel interface circuit board connectors</b> .....	<b>6-33</b>
<b>Figure 6-23: Screw locations for the interface circuit board</b> .....	<b>6-34</b>
<b>Figure 6-24: Cut-away view showing wire routing of fan and speaker wires</b> .....	<b>6-35</b>
<b>Figure 6-25: Backplane orientation and screw locations</b> .....	<b>6-37</b>
<b>Figure 6-26: CPU Jumper setting locations</b> .....	<b>6-39</b>
<b>Figure 6-27: Placement of bottom spacer pad in inner shipping box</b>	<b>6-42</b>
<b>Figure 6-28: Repackaging</b> .....	<b>6-43</b>
<b>Figure 8-1: Chassis parts</b> .....	<b>8-6</b>
<b>Figure 8-2: Modules and mounting hardware</b> .....	<b>8-9</b>
<b>Figure 8-3: Front panel parts</b> .....	<b>8-11</b>
<b>Figure 8-4: Cables</b> .....	<b>8-13</b>
<b>Figure 8-5: Cabinet parts and accessories</b> .....	<b>8-16</b>

# List of Tables

<b>Table 1-1: DSP board</b> .....	<b>1-5</b>
<b>Table 1-2: NTSC/PAL Decoder board</b> .....	<b>1-6</b>
<b>Table 1-3: NTSC/PAL Encoder board</b> .....	<b>1-7</b>
<b>Table 1-4: System components</b> .....	<b>1-9</b>
<b>Table 1-5: Rear panel interface</b> .....	<b>1-10</b>
<b>Table 1-6: Side panel interface characteristics</b> .....	<b>1-11</b>
<b>Table 1-7: AC power source characteristics</b> .....	<b>1-12</b>
<b>Table 1-8: Mechanical characteristics</b> .....	<b>1-12</b>
<b>Table 1-9: Environmental characteristics</b> .....	<b>1-13</b>
<b>Table 1-10: Electromagnetic compatibility</b> .....	<b>1-14</b>
<b>Table 1-11: Environmental limits and use classification for safety certification compliance</b> .....	<b>1-15</b>
<b>Table 2-1: Operating requirements</b> .....	<b>2-2</b>
<b>Table 2-2: Standard Accessories</b> .....	<b>2-3</b>
<b>Table 2-3: Additional standard accessories for Option 01 systems</b> .	<b>2-3</b>
<b>Table 2-3: Additional standard accessories for Option LC</b> .....	<b>2-4</b>
<b>Table 2-4: Optional Accessories</b> .....	<b>2-4</b>
<b>Table 2-5: Soft key control behavior</b> .....	<b>2-9</b>
<b>Table 4-1: Required equipment list</b> .....	<b>4-2</b>
<b>Table 4-2: Impaired video test sequences disk</b> .....	<b>4-5</b>
<b>Table 4-3: Mobile+.601-525 impaired video test sequence results and correction values</b> .....	<b>4-9</b>
<b>Table 4-4: Mobile+.601-625 impaired video test sequence results</b> ..	<b>4-10</b>
<b>Table 4-5: Test oscilloscope settings</b> .....	<b>4-12</b>
<b>Table 4-6: Summary PQR for unimpaired sequence using a 601 digital reference sequence</b> .....	<b>4-26</b>
<b>Table 4-7: Summary PQR for unimpaired sequence using a captured composite reference</b> .....	<b>4-28</b>
<b>Table 4-8: Mobile+ NTSC and NTSC No Setup impaired video test sequence results for composite video</b> .....	<b>4-30</b>
<b>Table 4-9: Mobile+ PAL impaired video test sequence results for composite video</b> .....	<b>4-30</b>
<b>Table 4-10: Summary picture quality values for unimpaired sequence against 601 serial digital reference</b> .....	<b>4-31</b>

---

<b>Table 4-11: Summary picture quality values for unimpaired sequence against captured S-Video reference using Simple processing ..</b>	<b>4-32</b>
<b>Table 4-12: Mobile+ NTSC and NTSC No Setup impaired video test sequence results for S-Video .....</b>	<b>4-32</b>
<b>Table 4-13: Mobile+ PAL impaired video test sequence results for S-Video .....</b>	<b>4-32</b>
<b>Table 4-14: Frequency counter setup .....</b>	<b>4-43</b>
<b>Table 5-1: Required equipment list .....</b>	<b>5-1</b>
<b>Table 5-2: Frequency counter setup .....</b>	<b>5-2</b>
<b>Table 6-1: Static susceptibility .....</b>	<b>6-1</b>
<b>Table 6-2: CPU Speed settings .....</b>	<b>6-37</b>
<b>Table 6-3: Flat panel jumper settings .....</b>	<b>6-38</b>
<b>Table 6-4: Packaging material .....</b>	<b>6-39</b>
<b>Table 7-1: Power cord options .....</b>	<b>7-1</b>
<b>Table C-1: Video test sequences for 601-525 format .....</b>	<b>C-1</b>
<b>Table C-2: Video test sequences for 601-625 format .....</b>	<b>C-2</b>
<b>Table C-3: Impaired video test sequences disk .....</b>	<b>C-2</b>



# General Safety Summary

Review the following safety precautions to avoid injury and prevent damage to this product or any products connected to it. To avoid potential hazards, use this product only as specified.

*Only qualified personnel should perform service procedures.*

## **To Avoid Fire or Personal Injury**

**Use Proper Power Cord.** Use only the power cord specified for this product and certified for the country of use.

**Ground the Product.** This product is grounded through the grounding conductor of the power cord. To avoid electric shock, the grounding conductor must be connected to earth ground. Before making connections to the input or output terminals of the product, ensure that the product is properly grounded.

**Provide Proper Ventilation.** Refer to the manual's installation instructions for details on installing the product so that it has proper ventilation.

**Observe All Terminal Ratings.** To avoid fire or shock hazard, observe all ratings and markings on the product. Consult the product manual for further ratings information before making connections to the product.

**Do Not Operate Without Covers.** Do not operate this product with covers or panels removed.

**Use Proper Fuse.** Use only the fuse type and rating specified for this product.

**Do Not Operate With Suspected Failures.** If you suspect there is damage to this product, have it inspected by qualified service personnel.

**Do Not Operate in Wet/Damp Conditions.**

**Do Not Operate in an Explosive Atmosphere.**

**Keep Product Surfaces Clean and Dry.**

**Symbols and Terms**

**Terms in this Manual.** These terms may appear in this manual:



---

**WARNING.** *Warning statements identify conditions or practices that could result in injury or loss of life.*

---



---

**CAUTION.** *Caution statements identify conditions or practices that could result in damage to this product or other property.*

---

**Terms on the Product.** These terms may appear on the product:

DANGER indicates an injury hazard immediately accessible as you read the marking.

WARNING indicates an injury hazard not immediately accessible as you read the marking.

CAUTION indicates a hazard to property including the product.

**Symbols on the Product.** The following symbols may appear on the product:



CAUTION  
Refer to Manual



Protective Ground  
(Earth) Terminal



# Service Safety Summary

Only qualified personnel should perform service procedures. Read this *Service Safety Summary* and the *General Safety Summary* in the product service manual or the instruction manual.

**Do Not Service Alone.** Do not perform internal service or adjustments of this product unless another person capable of rendering first aid and resuscitation is present.

**Disconnect Power.** To avoid electric shock, switch off the instrument power, then disconnect the power cord from the mains power.

**Use Care When Servicing With Power On.** Dangerous voltages or currents may exist in this product. Disconnect power, remove battery (if applicable), and disconnect test leads before removing protective panels, soldering, or replacing components.

To avoid electric shock, do not touch exposed connections.



# Preface

This manual contains the servicing information for the PQA300 Picture Quality Analysis System. This information explains how to verify, service, troubleshoot, and repair the system to the module level.

- *Specifications* describes functional characteristics and performance requirements for the PQA300 Picture Quality Analysis System.
- *Operating Information* tells you how to install and operate the instrument.
- *Theory of Operation* provides descriptions of the PQA300 system modules.
- *Performance Verification* describes how to verify the functional performance of the PQA300 system.
- *Adjustment Procedures* gives the adjustment procedures.
- *Maintenance* contains the following information:
  - How to safely handle static sensitive modules and components
  - How to remove and replace modules
  - Diagnostic and Troubleshooting information and procedures
- *Options* provides a brief description of the available options for the PQA300 system.
- *Replaceable Parts* gives all module and mechanical parts that comprise the PQA300 system.
- The appendices consist of the following items:
  - *Appendix A* provides the procedure to follow if the operating system software needs to be repaired. Installing the application software and loading the video test sequences are also explained.
  - *Appendix B* describes the PQA300 application directory structure and the supporting files.
  - *Appendix C* provides a listing of the 601-525 and 601-625 video test sequences on each of the CD-ROM disks. The scene characteristics are also given.

## Related Manuals

The PQA300 Picture Quality Analysis System user documentation consists of the following:

- The *PQA300 Picture Quality Analyzer User Manual* details how to operate this picture quality analysis system.

## Manual Conventions

The following terms and conventions are used throughout this manual:

- The terms instrument and system refer to the PQA300 Picture Quality Analysis System.

# Introduction

This manual contains maintenance information for the PQA300 Picture Quality Analysis System. You should read this introduction before you service the instrument.

## Before You Begin

This manual is for servicing the PQA300 Picture Quality Analysis System. To prevent injury to yourself or damage to the PQA300 system, fulfill the following requirements:

- Repair should be performed only by a qualified service person.
- Read the Safety Summary at the beginning of this manual before beginning service.
- Read *Service Strategy*, below, before beginning service.
- When using this manual to service your PQA300 system, be sure to heed all warnings, cautions, and notes.

## Service Strategy

This manual contains the following maintenance and repair procedures:

- Periodic maintenance
- Performance verification
- Field adjustments
- Module removal and replacement
- Module-level fault diagnosis

Once you isolate a problem with a module, use the *Replaceable Parts List* in this manual to determine the correct module part number to order from Tektronix.

## Tektronix Service Offerings

Tektronix provides service to cover repair under warranty. Other services are available that may provide a cost-effective answer to your service needs.

Whether providing warranty repair service or any of the other services listed below, Tektronix service technicians, trained on Tektronix products, are best equipped to service your PQA300 system. Tektronix technicians are apprised of the latest information on improvements to the product as well as the latest product options.

### Warranty Repair Service

Tektronix warrants this product for one year from the date of purchase. (The warranty appears after the title page and copyright page in this manual.) Tektronix technicians provide warranty service at most Tektronix service locations worldwide. Your Tektronix product catalog lists all service locations worldwide.

### Repair Service

Tektronix offers single per-incident and annual maintenance agreements that provide Depot Service repair of this product.

Of these services, the annual maintenance agreement offers a particularly cost-effective approach to service for many owners of the PQA300 Picture Quality Analysis System. Such agreements can be purchased to span several years.

### Self Service

Tektronix supports repair to the module level by offering a Module Exchange program.

**Module Exchange.** This service reduces down time for repair by allowing you to exchange most modules for remanufactured ones. Tektronix ships you an updated and tested exchange module from the Beaverton, Oregon, service center. Each module comes with a 90-day service warranty.

**For More Information.** Contact your local Tektronix service center or sales engineer for more information on any of the repair or adjustment services previously described.

## Contacting Tektronix

<b>Phone</b>	1-800-833-9200*
<b>Address</b>	Tektronix, Inc. Department or name (if known) 14200 SW Karl Braun Drive P.O. Box 500 Beaverton, OR 97077 USA
<b>Web site</b>	<a href="http://www.tektronix.com">www.tektronix.com</a>
<b>Sales support</b>	1-800-833-9200, select option 1*
<b>Service support</b>	1-800-833-9200, select option 2*
<b>Technical support</b>	Email: <a href="mailto:techsupport@tektronix.com">techsupport@tektronix.com</a> 1-800-833-9200, select option 3* 6:00 a.m. - 5:00 p.m. Pacific time

---

\* **This phone number is toll free in North America. After office hours, please leave a voice mail message. Outside North America, contact a Tektronix sales office or distributor; see the Tektronix web site for a list of offices.**







# Specifications

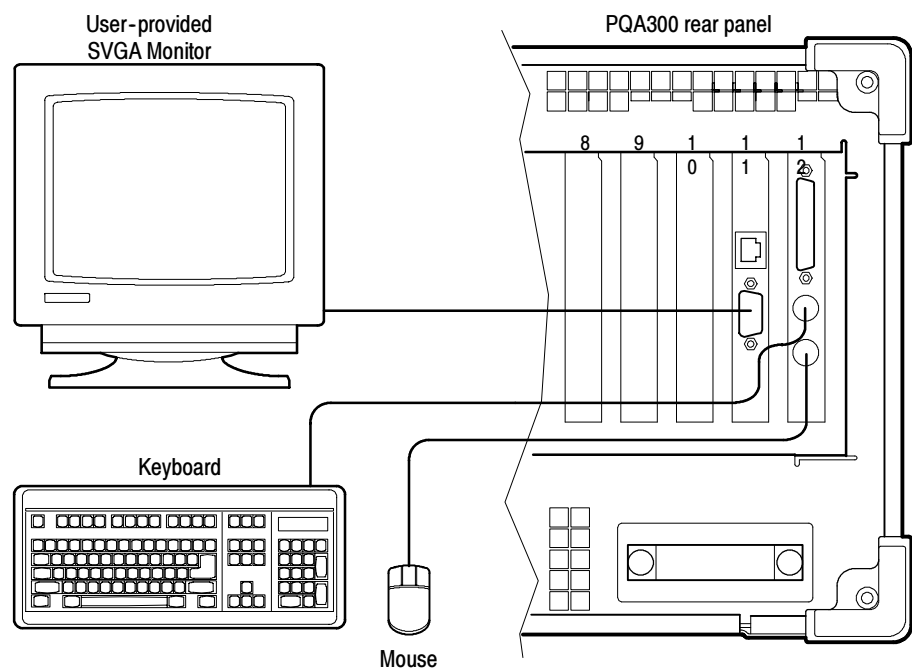


# Specifications

This section lists the electrical, physical, and environmental characteristics of the PQA300 Picture Quality Analysis System.

## Product Description

The PQA300 analysis system uses Microsoft® Windows NT Workstation 4.0 as its operating system (see Figure 1-1). The PQA300 Picture Quality Analysis System has a standard configuration that can be used to determine the picture quality of 601 serial digital video test sequences. The addition of Option 01, the composite video option, permits the testing of composite video test sequences.



**Figure 1-1: Components of the PQA300 Picture Quality Analysis System**

The system consists of the following components:

- The key system components are the Analyzer DSP module and the Generator DSP module. These are identical modules.
- The Option LC provides an integrated display, touch screen, U.S. keyboard, keypad and three-button mouse.
- The Composite video option consists of the composite decoder module (for capture of composite video) and the composite video encoder module (for the generation of composite video test sequences).
- PQA300 Picture Quality Analysis System application software consists of the user interface, video capture, measurement, and results presentation. It also has the generate application. Additional support features include setups, printing, and a 601 digital video signal output for external display.

## Features

The standard PQA300 Picture Quality Analysis System can determine the picture quality of 601 serial digital video test sequences. With the addition of Option 01 (composite video), you can test composite video test sequences.

You can use this system to do the following tasks:

- Generate video test sequences in serial digital component (and with Option 01, composite analog signal formats).
- Capture video test sequences in serial digital component (and with Option 01, composite analog signal formats).
- Create generate and reference video sequences from your selected program material to use for PQR and PSNR measurements.
- Make PQR and PSNR picture quality measurements on captured and stored video test sequences.
- Compare results from multiple measurements.
- Select an area of the fields and/or a range of fields on which to make picture quality measurements.
- Display live video on an SVGA monitor.
- Display reference video, captured video, and result maps (PQR and PSNR) on screen (with option LC), on an SVGA monitor, or on a serial digital video display monitor (using the 601 serial digital output).
- Display a selected field of the reference sequence, captured sequence, or results map.
- Set the brightness and contrast of the picture difference results map displays.

- Display measurement results in various modes - graphs, details, summary, and picture difference maps - with rapid switching through the results display modes to compare data.
- Designate trace colors for the results graphs.
- Choose to apply preprocessing corrections to the detected gain, level, shift, and cropping prior to making measurements.
- Create function files that perform a complete measurement: generate a sequence, capture and measure it, and display the measurement results.
- Define preference setups that restore often-used application configurations.
- Load reference and generator video test sequences from CD-ROM.
- Store and retrieve results to and from a floppy disk, the hard disk, or the network file systems (when connected to a network).
- Configure system settings such as time-outs, measurement limits, and display model parameters.
- Enter control commands through the keyboard and with mouse clicks on the virtual front panel display.
- Print results and screen captures or save them as PostScript or ASCII text files for later printing or transfer to other applications such as a spreadsheet or database program.
- Access online help for the system.

## Specification Tables

The tables list the specifications for the PQA300 Picture Quality Analysis System. Refer to the following definitions for an explanation of each specification table column heading.

The following definitions describe the information you will find in the specification tables.

- **Specification.** A document or a section of a document that lists and describes characteristics and performance requirements of equipment and certain programming material.
- **Characteristic.** A property of the product.
- **Description.** A statement that describes a characteristic usually in limit form. This statement is considered to be binding on the company (seller), and can be verified by performing the appropriate portion of the Performance Verification Procedure, or by a separate and available procedure.
- **Supplemental information.** Statements that explain performance requirements or provide performance information. These are not considered to be statements of guaranteed performance and are not ordinarily supported by a performance check.

## Performance Conditions

The Performance requirements are valid within the environmental limits if the instrument is adjusted at  $25^{\circ} \text{C} \pm 5^{\circ} \text{C}$  and you allow a minimum warm-up time of 20 minutes.

## Hardware Specifications

**Table 1-1: DSP board**

Characteristic	Description	Supplemental information
Input Signal Format	Receives 270 MB/s serial digital signal	Complies with ITU-R BT.601, BT.656, and SMPTE 259M
Channel A: 601 In and 601 Out		Active loop-through BNC, 75 $\Omega$ terminating
Channel 2: Ref In and Ref Out		Active loop-through SMB, 75 $\Omega$ terminating
Channel 1 to Channel 2 Isolation		30 dB to 300 MHz
Input Return Loss		At least 15 dB (1 MHz to 270 MHz), with power on
Serial Receiver Equalization Range		Proper operation with coaxial cable up to 14.5 dB loss at 135 MHz. Typical operation; to 300 meters with Belden 8281 coaxial cable.
Active loop-through output characteristics		Meets SMPTE 259M levels and rise and fall times. No reclocking is done on loop-through output.
Loop Output Return Loss		At least 15 dB (1 MHz to 270 MHz), with power on
Output Signal Format	270 MB/s serial digital signal	Complies with ITU-R BT.601, BT.656, and SMPTE 259M. Exception: output frequency accuracy only specified when not referenced to an external input signal.
Output impedance		75 $\Omega$
Return Loss		At least 15 dB (1 to 270 MHz), with power on
Output level	800 mV $\pm$ 80 mV	
Rise/Fall		0.3 ns to 1.2 ns, measured 20% to 80%
Jitter - Internal Reference		Less than 0.2 UI, typically 0.3 ns peak-to-peak
Jitter - External Reference		Depends on the reference input. Typically peaking at 0.05 dB. Jitter attenuation 3 dB point is typically at 650 kHz.
Frequency	270 Mbit/s	
Frequency accuracy		$\pm$ 1.5 ppm over temperature range plus $\pm$ 1 ppm per year drift, when using the internal oscillator
Output Connector		BNC

**Table 1-2: NTSC/PAL Decoder board**

Characteristic	Performance requirement	Supplemental information
Input Channels		
Video Format	NTSC, NTSC No Setup, PAL (B, D, G, H, and I)	
Composite Input type		Passive loop-through, 75 $\Omega$ , compensated, BNC
Return loss		40 dB up to 6 MHz on composite video
Loop-through insertion loss		0.6dB Max to 6MHz for composite video
Input amplitude range		+5%, -20% typical
Hum range	0.5 V peak-to-peak	
Frequency range		$\pm 20$ ppm
Genlock jitter		0.5 degree on 0 dB signal, -20 dB hum, -50 dB SNR
S-Video Input type		Standard S-Video and connector. No loop-through, terminated.
Return loss		25 dB typical
601 Out (serial digital video)		
Connectors		One BNC, one SMB. Identical signals on both output connectors.
Format	270 MB/s serial component only	Complies with ITU-R BT.601, BT.656, and SMPTE 259M
Output level	800 mV $\pm$ 80 mV	
Rise/Fall	0.4 ns to 1.2 ns, measured 20% to 80%	
Jitter	< 0.2UI above 10 Hz	
Output impedance		75 $\Omega$ , 15 dB return loss 5 to 270 MHz
Frequency		270 Mbit/s nominal, tracks input signal
Output mode		8 bit or 9 bit, not user selectable
Conversion Accuracy		
Gain	1 $\pm$ 2% low frequency	
Flatness	1% to 5 MHz for luma, relative to 500 kHz	
Luma linearity		2%
Differential Gain		1%
Differential Phase		1 degree
Black Level Error		10 mV



Table 1-3: NTSC/PAL Encoder board

Characteristic	Performance requirement	Supplemental information
Genlock (analog black burst) input	Burst locks to NTSC or PAL composite video	Does not lock to monochrome input video
Format	NTSC, NTSC No Setup, PAL (B, D, G, H, and I)	
Input type		Passive loop-through, BNC, 75 $\Omega$ , compensated
Return loss		40 dB to 6 MHz on composite video
Loop-through insertion loss		0.6 dB maximum to 6 MHz for composite video
Color Framing (Genlocked to input reference)		Correct color framing detected for signals having no greater than $\pm 45$ degrees SCH phase error. Color framing is maintained, once obtained, until the SCH phase error exceeds a nominal value of 125 degrees. Burst must be present and be within $\pm 3$ dB of nominal levels.
Burst lock jitter		SNR > 50 dB  SNR is defined as the ratio of 0.714 $V_{P-P}$ video to the RMS value of white gaussian noise over a 5 MHz bandwidth
Genlock noise performance		Genlock will be maintained with a SNR > 40 dB or 60 Hz hum < 0.714 $V_{P-P}$
Burst lock phase change with input burst amplitude		$\leq 2.5$ degrees over a burst amplitude range of nominal value $\pm 3$ dB
Burst lock phase change with input signal APL		$\leq 1$ degree over input signal APL range of 10% to 90%
Output Channels		
Analog video format	NTSC, NTSC No Setup, PAL (B, D, G, H, and I)	NTSC; SMPTE 170M, with and without pedestal. PAL; CCIR 625
Composite output		75 $\Omega$ BNC
Composite return loss		>40 dB to 5.5 MHz at 75 $\Omega$
S-Video (Y/C) output		75 $\Omega$ Standard S-Video
Y/C S-video crosstalk		$\geq 50$ dB down
S-video return loss		25 dB typical, to 5.5 MHz at 75 $\Omega$
601 In		
Format	270 MB/s serial component video	Complies with ITU-R BT.601, BT.656, and SMPTE 259 M
Input type		Non loop-through, 75 $\Omega$ terminated SMB
Return loss		$\geq 15$ dB to 270 MHz

**Table 1-3: NTSC/PAL Encoder board (cont.)**

Characteristic	Performance requirement	Supplemental information
Serial receiver equalization range		Proper operation with coaxial cable up to 14.5 dB loss at 135 MHz using coaxial cable with $1/\sqrt{F}$ loss characteristics.  Nominally 150 meters of Belden 8281 coaxial cable.
Serial Black Out		
Format	270 MB/s serial component video	Complies with ITU-R BT.601, BT.656, and SMPTE 259M
Output type		75 $\Omega$ , SMB
Amplitude	800 mV $\pm$ 100 mV	
Rise/Fall time		0.3 ns to 1.2 ns, measurement 20% to 80%
Return loss		$\geq$ 15 dB from 5 MHz to 270 MHz
Jitter		$\leq$ 0.2 UI above 10 Hz. Only when burst genlocked.
Encoder Conversion Accuracy at Output		
Amplitude accuracy	Within 1%	
Frequency response		Within 1% to 5 MHz, relative to 400 kHz
Group delay		10 ns or less at 5 MHz, relative to luma transition
Luminance Linearity		$\leq$ 1%, measured with a 5-step staircase
Differential Gain		$\leq$ 0.5%
Differential phase		$\leq$ 0.5 degree
Chrominance to Luminance Gain Error		$\leq$ 2%
Chrominance to Luminance Delay Error		$\leq$ 7 ns
Field and Line Tilt		$\leq$ 0.5%
S/N Ratio	$\geq$ 60 dB (unweighted, 5 MHz low-pass filtered)	
Composite DC offset	$\leq$ 50 mV	

## System Components

**Table 1-4: System components**

Characteristic	Supplemental information
Mainframe	Tektronix manufactured, common-platform mainframe
Form Factor	Rack-mountable in standard 19-inch rack. Optional local display, mouse and keyboard.
Processor	Two 400 MHz Pentium II processors
System Memory	256 MB
Real Time Clock	Real-time clock/calendar with a resolution of 1 second or less
Retention Time: Real-time clock, CMOS setup, and PnP NVRAM	Projected battery life is typically 10 years
BIOS	Phoenix BIOS, field upgradable
Bus	32-bit PCI
Expansion Slots	8 PCI slots
Graphics	
External VGA connector	1024 × 768 SVGA resolution with 32 k colors minimum
Optional local display	800 × 600 resolution with 32 k colors minimum
Non-volatile Storage	
Floppy Disk drive	Standard 3.5 inch PC compatible disk drive; 1.44-MB high-density double sided (2HD)
CD-ROM drive	PC compatible half height IDE CD-ROM drive, 8X
Hard Disk Drives	Standard PC compatible Small Computer Systems Interface (SCSI) HDD. Two drives of 9.1 Gbyte capacity each. Captured video sequences and other user files are striped on both hard drives.
Mainframe Interfaces	<ul style="list-style-type: none"> <li>■ One loop-through ethernet port</li> <li>■ One bi-directional RS-232/RS-422/RS-485 port</li> <li>■ One parallel port (printer)</li> <li>■ Two hot-pluggable keyboard ports (on the rear panel and the left front side panel).</li> <li>■ Two hot-pluggable mouse ports (on the rear panel and the left front side panel).</li> </ul> <p>Use either connector to connect only one keyboard and only one mouse.</p>
External Display	
SVGA Monitor	An SVGA monitor can be attached for external display of the user interface.
Digital Picture Monitor Output	An ancillary display can be attached. The output protocol is ITU-R BT.601.
Front Panel	Virtual front panel on external display monitor; requires optional mouse and keyboard.

**Table 1-4: System components (Cont.)**

Characteristic	Supplemental information
Internal Display (optional local control)	LCD, 6-bit, 250 NIT, CCFL backlight, 0. 264 MM pixel
Size	10.4 in. Diagonal
Resolution	800 X 600 (SVGA)
Touch Panel	Standard 10.4 in. touch panel pointing device mounted on the surface of the TFT display, connecting to the Front Panel Interface Board.

**Table 1-5: Rear panel interface**

Characteristic	Description																										
Parallel interface port	<p>Port supports standard Centronics mode, Enhanced Parallel Port (EPP), or Microsoft high-speed mode (ECP) and utilizes a 25-pin D-sub connector.</p> <p>Compliant with IEEE P1284-C/D2 for bi-directional Parallel Peripheral Interface for Personal Computers (draft) style 1284-C.</p> <p>Pin assignments for compatible mode:</p> <table> <tr> <td>1. STROBE*</td> <td>14. AUTOLF*</td> </tr> <tr> <td>2. D0</td> <td>15. ERR*</td> </tr> <tr> <td>3. D1</td> <td>16. INIT*</td> </tr> <tr> <td>4. D2</td> <td>17. SELECTIN*</td> </tr> <tr> <td>5. D3</td> <td>18. STROBE*</td> </tr> <tr> <td>6. D4</td> <td>19. GND</td> </tr> <tr> <td>7. D5</td> <td>20. GND</td> </tr> <tr> <td>8. D6</td> <td>21. GND</td> </tr> <tr> <td>9. D7</td> <td>22. GND</td> </tr> <tr> <td>10. ACK*</td> <td>23. GND</td> </tr> <tr> <td>11. BUSY</td> <td>24. GND</td> </tr> <tr> <td>12. PaperEnd</td> <td>25. GND</td> </tr> <tr> <td>13. SELECT.</td> <td></td> </tr> </table>	1. STROBE*	14. AUTOLF*	2. D0	15. ERR*	3. D1	16. INIT*	4. D2	17. SELECTIN*	5. D3	18. STROBE*	6. D4	19. GND	7. D5	20. GND	8. D6	21. GND	9. D7	22. GND	10. ACK*	23. GND	11. BUSY	24. GND	12. PaperEnd	25. GND	13. SELECT.	
1. STROBE*	14. AUTOLF*																										
2. D0	15. ERR*																										
3. D1	16. INIT*																										
4. D2	17. SELECTIN*																										
5. D3	18. STROBE*																										
6. D4	19. GND																										
7. D5	20. GND																										
8. D6	21. GND																										
9. D7	22. GND																										
10. ACK*	23. GND																										
11. BUSY	24. GND																										
12. PaperEnd	25. GND																										
13. SELECT.																											
Serial interface port	<p>9-pin male-D-sub connector to support RS232 serial port. Compliant to EIA/TIA 574</p> <p>Pin Assignments (RS232):</p> <table> <tr> <td>1. DCD</td> <td>6. DSR</td> </tr> <tr> <td>2. RXD</td> <td>7. RTS</td> </tr> <tr> <td>3. TXD</td> <td>8. CTS</td> </tr> <tr> <td>4. DTR</td> <td>9. RI</td> </tr> <tr> <td>5. GND</td> <td></td> </tr> </table> <p>Pin Assignments (RS485):</p> <table> <tr> <td>1. RXD-</td> <td>6. CTS-</td> </tr> <tr> <td>2. RXD+</td> <td>7. RTS+</td> </tr> <tr> <td>3. TXD+</td> <td>8. CTS+</td> </tr> <tr> <td>4. TXD-</td> <td>9. RTS-</td> </tr> <tr> <td>5. GND</td> <td></td> </tr> </table>	1. DCD	6. DSR	2. RXD	7. RTS	3. TXD	8. CTS	4. DTR	9. RI	5. GND		1. RXD-	6. CTS-	2. RXD+	7. RTS+	3. TXD+	8. CTS+	4. TXD-	9. RTS-	5. GND							
1. DCD	6. DSR																										
2. RXD	7. RTS																										
3. TXD	8. CTS																										
4. DTR	9. RI																										
5. GND																											
1. RXD-	6. CTS-																										
2. RXD+	7. RTS+																										
3. TXD+	8. CTS+																										
4. TXD-	9. RTS-																										
5. GND																											

**Table 1-5: Rear panel interface (Cont.)**

<b>Characteristic</b>	<b>Description</b>																
SVGA Output Port	<p>15-pin female high density-D-sub SVGA connector. Compliant with EIA RS 343A. Selectable 640 X 480 (VGA), 800 X 600, and 1024 X 768 (SVGA).</p> <p>Pin assignments:</p> <table> <tr> <td>1. Red</td> <td>9. (key)</td> </tr> <tr> <td>2. Green</td> <td>10. GND</td> </tr> <tr> <td>3. Blue</td> <td>11. NC</td> </tr> <tr> <td>4. NC</td> <td>12. NC</td> </tr> <tr> <td>5. GND</td> <td>13. HSYNC</td> </tr> <tr> <td>6. AGND</td> <td>14. VSYNC</td> </tr> <tr> <td>7. AGND</td> <td>15. NC</td> </tr> <tr> <td>8. AGND</td> <td></td> </tr> </table>	1. Red	9. (key)	2. Green	10. GND	3. Blue	11. NC	4. NC	12. NC	5. GND	13. HSYNC	6. AGND	14. VSYNC	7. AGND	15. NC	8. AGND	
1. Red	9. (key)																
2. Green	10. GND																
3. Blue	11. NC																
4. NC	12. NC																
5. GND	13. HSYNC																
6. AGND	14. VSYNC																
7. AGND	15. NC																
8. AGND																	
USB Port	<p>Series A USB receptacle</p> <p>Pin assignments:</p> <table> <tr> <td>1. Vbus</td> <td>3. +Data</td> </tr> <tr> <td>2. -Data</td> <td>4. GND</td> </tr> </table>	1. Vbus	3. +Data	2. -Data	4. GND												
1. Vbus	3. +Data																
2. -Data	4. GND																
Ethernet Port	<p>10 Base-T/100 Base-T on PCI bus, RJ45 Connector, Plug &amp; Plan compatible, Bus master mode.</p> <p>RJ45 Pin assignments:</p> <table> <tr> <td>1. TX+</td> <td>5. NC</td> </tr> <tr> <td>2. TX-</td> <td>6. RX-</td> </tr> <tr> <td>3. RX+</td> <td>7. NC</td> </tr> <tr> <td>4. NC</td> <td>8. NC</td> </tr> </table>	1. TX+	5. NC	2. TX-	6. RX-	3. RX+	7. NC	4. NC	8. NC								
1. TX+	5. NC																
2. TX-	6. RX-																
3. RX+	7. NC																
4. NC	8. NC																

**Table 1-6: Side panel interface characteristics**

<b>Characteristic</b>	<b>Description</b>						
Mouse Port	<p>PS2 compatible mouse port utilizing a mini-DIN connector. Pin assignments:</p> <table> <tr> <td>1. data</td> <td>4. +5 V</td> </tr> <tr> <td>2. NC</td> <td>5. clock</td> </tr> <tr> <td>3. ground</td> <td>6. NC</td> </tr> </table>	1. data	4. +5 V	2. NC	5. clock	3. ground	6. NC
1. data	4. +5 V						
2. NC	5. clock						
3. ground	6. NC						
Keyboard Port	<p>PS2 compatible keyboard port utilizing a mini-DIN connector. Pin assignments:</p> <table> <tr> <td>1. data</td> <td>4. +5 V</td> </tr> <tr> <td>2. NC</td> <td>5. clock</td> </tr> <tr> <td>3. ground</td> <td>6. NC</td> </tr> </table>	1. data	4. +5 V	2. NC	5. clock	3. ground	6. NC
1. data	4. +5 V						
2. NC	5. clock						
3. ground	6. NC						
USB Port	<p>Series A USB receptacle. Pin assignments:</p> <table> <tr> <td>1. Vbus</td> <td>3. +Data</td> </tr> <tr> <td>3. +data</td> <td>4. GND</td> </tr> </table>	1. Vbus	3. +Data	3. +data	4. GND		
1. Vbus	3. +Data						
3. +data	4. GND						

## Power Specifications

**Table 1-7: AC power source characteristics**

Characteristic	Description
Source Voltage	100 VAC to 240 VAC, 50/60 Hz, continuous range CAT II
Fuse Rating	8 A Fast / 250 V
Maximum Power Consumption	330 Watts max, 145 Watts typical
Steady State Input Current	6 Amps max, 1.25 Amps RMS typical
Inrush Surge Current	36 Amps maximum
Power Factor Correction	Yes

## Mechanical (Physical) Characteristics

**Table 1-8: Mechanical characteristics**

Characteristic	Description
Classification	Transportable platform intended for either rackmount or bench/lab based applications.
Overall Dimensions	
Height	8.5 inches (w/o feet) (21.6 cm)
Width	17 inches (43.2 cm)
Depth	22 inches (55.9 cm)
Weight	42 lb (19.1 kg)
Shipping Weight	64 lb (29.1 kg)
Construction Materials	Chassis parts are constructed of aluminum alloy and aluminized steel; front panel and trim pieces are constructed of plastic; circuit boards are constructed of glass and/or ceramic-glass laminate.

## Environmental Characteristics

**Table 1-9: Environmental characteristics**

Characteristic	Description
Cooling airflow	Intake is from the front and sides of the instrument. Exhaust is to the bottom and rear of the instrument.
Required Clearance	2 in. (50 mm) air space adjacent to the bottom of the instrument is required.
Use Rating	Rated for indoor use only.
Atmospherics	
Temperature:	
Operating	5° C to 40° C (41° F to 104° F), 30° C (54° F)/hr max gradient, non-condensing (derated 1° C or 1.8° F per 1,000 ft. or 305 m above 5,000 ft. or 1524 m altitude)
Non-operating	-20° C to 60° C (-4° F to 140° F), 30° C (54° F)/hr max gradient (without disk media installed in disk drives)
Humidity	
Operating	20% to 80% relative humidity, non-condensing. Max wet bulb temperature: 29.4° C or 84.9° F (derates relative humidity to ~46% at 40° C or 104° F)
Non-operating	8% to 80% relative humidity, non-condensing. Max wet bulb temperature: 40° C or 104° F (derates relative humidity to ~54% at 50° C or 122° F)
Altitude	
Operating	2000 meters maximum.
Non-Operating	Up to 40,000 ft (12,190 m)

## Certification and Compliances

**Table 1- 10: Electromagnetic compatibility**

Category	Standards or description
EC Declaration of Conformity - EMC	<p>Meets the intent of Directive 89/336/EEC for Electromagnetic Compatibility.</p> <p>Compliances were demonstrated using EN 61326:1997 EMC Product Family Standard for Electrical Equipment for Measurement, Control, and Laboratory use.</p> <p>Emissions<sup>1</sup>:            EN 61326            Class A Radiated and Conducted Emissions            EN 61000-3-2(A14) Conducted Power Line Harmonic Current</p> <p>Immunity<sup>1,2</sup>:            IEC 61000-4-2      Electrostatic Discharge Immunity, Performance Criterion "B"            IEC 61000-4-3      Radiated RF Electromagnetic Field Immunity<sup>3,4</sup> Performance Criterion "A"            IEC 61000-4-4      Electrical Fast Transient/Burst Immunity, Performance Criterion "B"            IEC 61000-4-5      Power Line Surge Immunity, Performance Criterion "B"            IEC 61000-4-6      Conducted RF Immunity<sup>3</sup>, Performance Criterion "A"            IEC 61000-4-11     Voltage Dips and Short Interruptions Immunity, Performance Criterion "B"</p>
Australia Declaration of Conformity	Complies with EMC Framework and demonstrated per Emission standard: AS/NZS 2064 Industrial, Scientific, and Medical Equipment.
USA, FCC Compliance	Emissions comply with FCC Code of Federal Regulations 47, Part 15, Subpart B, Class A Limits.

<sup>1</sup> **Compliance demonstrated using high quality, shielded interface cables.**

<sup>2</sup> **Minimum immunity test requirement, except where noted.**

<sup>3</sup> **Performance Criterion: Product continues to operate properly and display remains readable.**

<sup>4</sup> **Controlled EM environment requirement (1V/M).**



**Table 1- 11: Environmental limits and use classification for safety certification compliance**

<b>Category</b>	<b>Standards or description</b>
Safety Certification Compliance	
Temperature, operating	+5° C to +40° C
Altitude (maximum operating)	2000 meters
Equipment Type	Test and measuring
Safety Class	Class 1 (as defined in IEC 61010-1, Annex H) - grounded product
Installation (Overvoltage) Category	Overvoltage Category II (as defined in IEC 61010-1, Annex J)
Pollution Degree	Pollution Degree 2 (as defined in IEC 61010-1). Note: Rated for indoor use only.
Supply Voltage Range	100 VAC to 240 VAC, 50/60 Hz, single phase
Fuse Rating	Mains fuse is 8A, 250 V, Fast; Not operator replaceable. Refer servicing to qualified service personnel.
Current Rating	6.0 Amps maximum
Relative Humidity (maximum operating)	80 % for temperatures up to 31° C, decreasing linearly to 50 % at 40° C
Pollution Degree Definition	<p>A measure of the contaminants that could occur in the environment around and within a product. Typically the internal environment inside a product is considered to be the same as the external. Products should be used only in the environment for which they are rated.</p> <p>Pollution Degree 1      No pollution or only dry, nonconductive pollution occurs. Products in this category are generally encapsulated, hermetically sealed, or located in clean rooms.</p> <p>Pollution Degree 2      Normally only dry, nonconductive pollution occurs. Occasionally a temporary conductivity that is caused by condensation must be expected. This location is a typical office/home environment. Temporary condensation occurs only when the product is out of service.</p> <p>Pollution Degree 3      Conductive pollution, or dry, nonconductive pollution that becomes conductive due to condensation. These are sheltered locations where neither temperature nor humidity is controlled. The area is protected from direct sunshine, rain, or direct wind.</p>
European Union Compliance	<p>Compliance was demonstrated to the following specification as listed in the Official Journal of the European Union:</p> <p>Low Voltage Directive 73/23/EEC, amended by 93/68/EEC</p> <p>EN 61010-1/A2      Safety Requirements for Electrical Equipment for Measurement Control and Laboratory Use.</p>
Listing by a U.S. Nationally Recognized Testing Laboratory	<p>ANSI/ISA S82.01      Safety Standard for Electrical and Electronic Test, Measuring, Controlling, and Related Equipment., 1994.</p>
Canadian Certification	<p>CAN/CSA C22.2 No. 1010.1      Safety Requirements for Electrical Equipment for Measurement, Control, and Laboratory Use.</p>

**Table 1- 11: Environmental limits and use classification for safety certification compliance (Cont.)**

Category	Standards or description
Additional Compliance	<p>UL3111-1                      Standard for Electrical Measuring and Test Equipment.</p> <p>IEC61010-1/A2              Safety Requirements for Electrical Equipment for Measurement, Control, and Laboratory Use.</p>
Installation (Overvoltage) Category	<p>Terminals on this product may have different installation (overvoltage) category designations. The installation categories are:</p> <p>CAT III    Distribution-level mains (usually permanently connected). Equipment at this level is typically in a fixed industrial location.</p> <p>CAT II    Local-level mains (wall sockets). Equipment at this level includes appliances, portable tools, and similar products. Equipment is usually cord-connected.</p> <p>CAT I    Secondary (signal level) or battery operated circuits of electronic equipment.</p>
Laser Classification	<p>This product contains a CD-ROM drive, which utilizes a Class 1 laser and complies with EN60825-1:94, as well as with the U.S. FDA regulations. The drive is marked with the laser's classification and the date of manufacture, as well as the following information: Complies with the DHHS rules 21 CFR Chapter 1, Subchapter J applicable at the date of manufacture.</p>



# Operating Information



# Operating Information

This section provides installation instructions and gives a brief overview of how to operate the PQA300 Picture Quality Analysis System.

## Installation



---

**CAUTION.** To avoid damage to the PQA300 system during shipping, retain the original shipping carton. Shipping the PQA300 system in any other packaging may void the warranty.

---

### Software Installation

All software is installed at the factory. If you need to reinstall it, refer to *Appendix C: Software Installation*.

### Hardware Installation

The standard instrument is shipped with a rackmount kit. For proper cooling, allow at least 2 inches (5.1 cm) of clearance on the rear and sides of the mainframe. Use the instructions provided with the rackmount kit to install the rackmount cradle in a standard rack and to install the PQA300 in the cradle.



---

**CAUTION.** For rack mounting, the product must be installed in its specified rack cradle as listed in Table 2-2. For proper cooling, the air temperature at all air intake vents (inside the rack) must not exceed 40 °C.

---

Before you can operate the product, you must connect the provided power cord. Refer to Figure 2-1 to connect the power cord to the instrument. Refer to Table 2-1 for the supply voltage rating and connect the other end of the power cord to the proper source. Do not connect to any power sources other than those for which the instrument is rated. For a complete specification list, refer to *Appendix A: Specifications*.



---

**CAUTION.** Keep the bottom of the instrument clear of obstructions to ensure proper cooling.

---

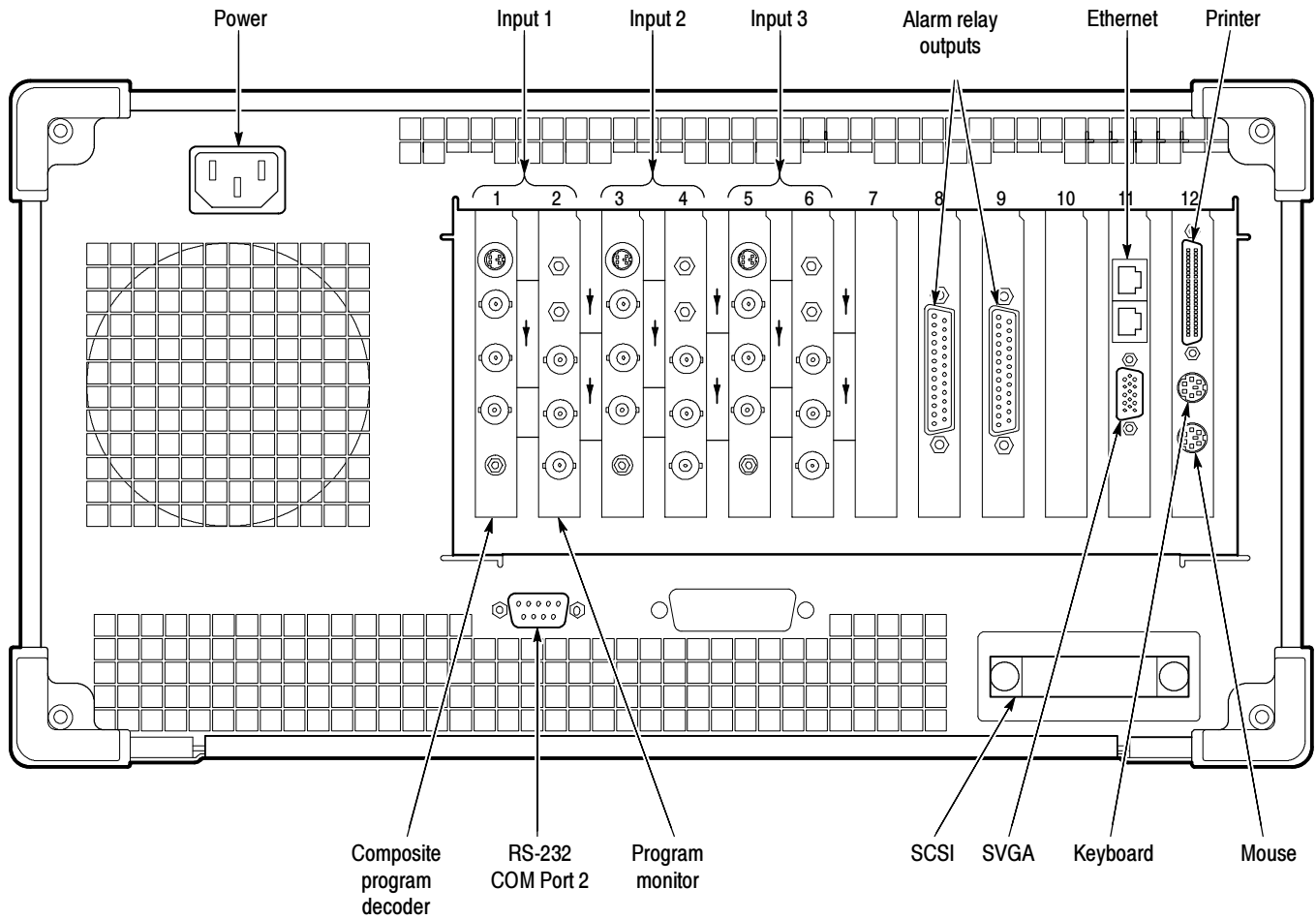


Figure 2- 1: PQA300 system rear panel

Table 2- 1: Operating requirements

Requirement	Specification
Source voltage	100-240 VAC <sub>RMS</sub> , 50 / 60 Hz
Steady State input current	6 A <sub>RMS</sub> maximum, 1.25 A <sub>RMS</sub> typical
Maximum power consumption	330 Watts max, 145 Watts typical
Temperature	5° C to +40° C (32° F to 104° F), 30° C/hr max gradient, non-condensing (derated 1° C per 1,000 ft. above 5,000 ft. altitude)
Humidity	20% to 80% relative humidity, non-condensing. Max wet bulb temperature: +29.4° C or 84.9° F (derates relative humidity to ~46% at 40° C or 104° F).
Altitude	2,000 meters maximum.

**Standard Accessories**

The standard PQA300 is shipped with the accessories listed in Table 2-2.

**Table 2-2: Standard Accessories**

<b>Description</b>	<b>Part number</b>
<i>PQA300 Picture Quality Analysis System User Manual</i>	071-0909-00
PQA300 Application Installation CD-ROM	063-3477-00
Emergency repair disk (use as described in the Windows NT System Guide)	063-3484-00
Rackmount kit with instructions	016-1691-01
Standard North American power cable	161-0066-00
CD-ROM set of 11 compact discs: 10 discs containing selected video test sequences for 525-line and 625-line video formats. 1 disc containing impaired video test sequences in 525-line and 625-line video formats with known and quantified impairments for testing the functional performance of the PQA300	063-3483-00
One low-loss 75 $\Omega$ double-shielded coaxial cable, length 72 inches, with BNC connectors for use in video signal interconnections	012-0159-01

The Option 01 system is shipped with the items listed in Table 2-3, in addition to the items listed in Table 2-2.

**Table 2-3: Additional standard accessories for Option 01 systems**

<b>Description</b>	<b>Part number</b>
One 75 $\Omega$ adapter coaxial cable, length 9 inches, with a male BNC connector on one end and a female SMB connector on the opposite end for encoder to generator DSP interconnection.	174-3916-00
Two 75 $\Omega$ coaxial cables, length 8 inches, with female SMB connectors on both ends for encoder to generator DSP and decoder to analyzer DSP interconnections.	174-3915-00
Two 75 $\Omega$ BNC terminations for use in terminating the passive loop-through connections of the encoder and decoder modules.	011-0102-01
Two S-Video cables, length 72 inches, with standard S-Video connectors on both ends for use in S-Video signal interconnections.	012-1554-00

The Option LC system is shipped with the items listed in Table 2-4, in addition to the items listed in Table 2-2.

**Table 2-4: Additional standard accessories for Option LC systems**

<b>Description</b>	<b>Part number</b>
One Keyboard, U.S.	118-9402-00
One Mouse, pointer	119-4330-02
Two Styluses for touch screen	119-6107-00

**Optional Accessories**

The following accessories must be purchased separately. Any one of the power cable options shown in Table 2-5 is provided at no charge when ordered with the instrument. The optional power cord replaces the standard North American power cord.

**Table 2-5: Optional Accessories**

<b>Description</b>	<b>Part number</b>
<i>PQA300 Picture Quality Analysis System Service Manual</i>	071-0914-00
Video monitor with serial digital component interface	User-supplied accessory
Power cord options	
Opt. A1 Universal Euro 230 V	161-0066-09
Opt. A2 United Kingdom 230 V	161-0066-10
Opt. A3 Australian 230 V	161-0066-11
Opt. A5 Swiss 230 V	161-0154-00
Opt. AC China 240 V	161-0304-00



# First Time Operation

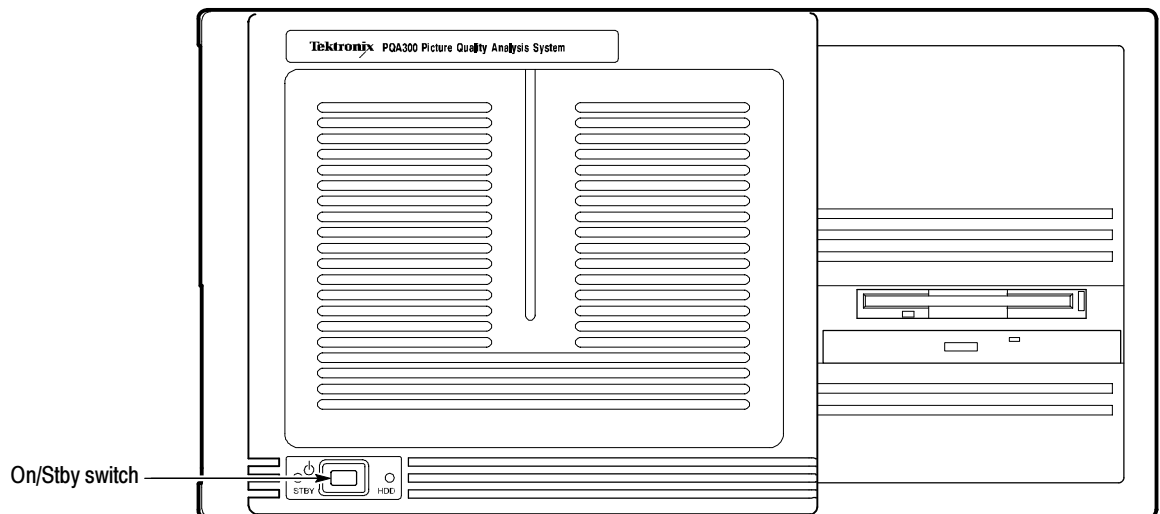
After you install the PQA300, it is ready to operate.

## First Time Power On

Power on the PQA300 for the first time as follows:

1. Connect an SVGA monitor for a display and a keyboard and mouse for user command inputs. See Figure 1-1 and Figure 1-2 for the connector locations. If you have the local control flat panel display installed (option LC), use the local display. You do not have to connect an external SVGA monitor. You can connect the keyboard and mouse either to the rear panel connectors or to the left side connectors.
2. Press the On/Stby switch to power on the instrument (see Figure 2-2 for the switch location).

Whenever you power on the PQA300, it initializes and starts the PQA300 application without the need to enter a user name and password as normally required for a Windows NT operating system. (For more information on the Windows NT initialization process, refer to Windows NT documentation.)



**Figure 2-2: On/Stby switch**

3. When the PQA300 application starts, click on the X in the upper right corner of the PQA300 application window to stop the PQA300 application.

---

**NOTE.** The PQA300 uses automatic login with the user name of Administrator and the password of PQA300. No other user can log in while the autologin property of the application is enabled.

If it becomes necessary to disable the automatic login, you must run the Regedit (registration edit) program and set the HKEY\_LOCAL\_MACHINE\SOFTWARE\Microsoft\Windows NT\CurrentVersion\Winlogon\AutoAdminLog value to 0. It must be reset to 1 to enable automatic login. See Configure for Auto Boot Up in Appendix C.

---

4. If autologin is disabled as described in the preceding note, use the key sequence CTRL + ALT + Delete to display the login dialog box. There are three possible logins:
  - You can log in as **Administrator** and use **PQA300** as the password. This user can load software, change passwords, assign users, and make the Windows NT system setups for the network.
  - You can log in as **PQA300** without entering any password. Use this login for normal use of the system for testing picture quality.
  - You can log in as **Guest** without entering any password. A guest has only limited access to files and applications.
5. Set the PQA300 clock to the correct system time.

If you have the ability to diagnose and repair module level defects, the service manual will aid you in module-level trouble isolation of the PQA300 modules. Once a problem module is identified, you can order an exchange replacement module. You will then have to install the module, configure the instrument as necessary, and do any system calibration that may be needed. Troubleshooting of the instrument is not included in the service manual.

## Preference Preset

The PQA300 Picture Quality Analysis System supports saving and recalling instrument configuration setups. A preference preset file contains all of the static configuration elements defining the PQA300 behavior. Once saved to the preference directory, a preset file can be used to restore that configuration of the instrument settings.

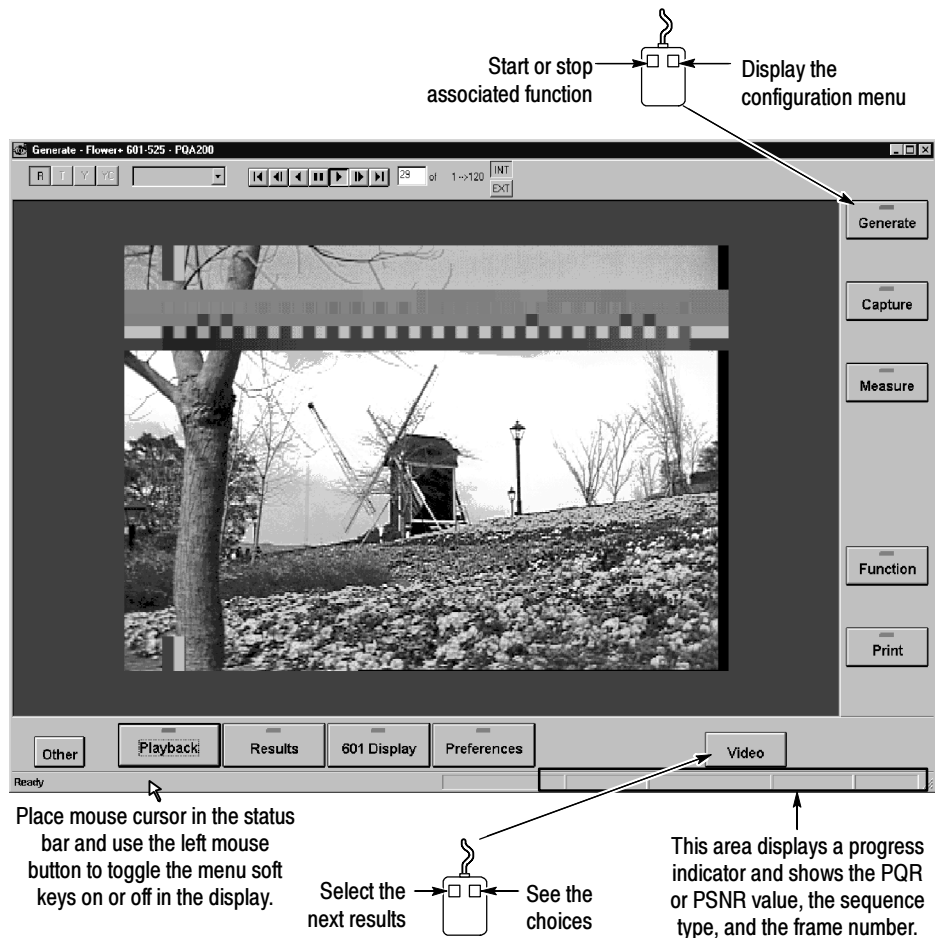
From the factory there is one preset installed and one created at the first shutdown of the PQA200 application. These are called factory and shutdown. The factory preset is a read-only file, which is used to set up the PQA300 for factory and service testing procedures. Use the factory preset to remove any settings remaining from previous operation and begin a new setup with known

settings. After making new configuration settings, give the preset a new name and save it to make a new preference preset.

At shutdown of the PQA300 application, the present settings are saved for restoration in a preference preset file called “shutdown.” If the shutdown preset is the selected preference preset for startup, those shutdown settings are restored the next time the application is started. For additional information on creating and activating preference presets, refer to *Preference Configuration Menu* in the *PQA300 Picture Quality Analysis System Service Manual*.

## Virtual Front Panel Controls, Indicators, and Display

Once you have correctly completed the login, you have access to the PQA300 application menus and displays. Double click on the PQA300 icon to start the application. The PQA300 Picture Quality Analysis System user interface consists of a virtual front panel (shown in Figure 2-3 with menus) and other configuration control panels that provide access to all the configuration settings and operating control choices.



**Figure 2-3: Virtual front panel with soft key menus**

The displays are viewed on the monitor, and all the controls are selected using the mouse pointer and activated by clicks or presses of the mouse buttons. The keyboard can be used to input alpha or numeric information when appropriate.

The arrow keys on the keyboard are used to step a changeable parameter up and down when that parameter is selected using the mouse cursor. The vertical cursor that is displayed in the graphical results display can also be positioned using both the arrow keys and the mouse cursor. The Windows NT operating controls provide access to any instrument configurations that must be made or changed.

## Soft Key Controls

The main control soft keys located to the right of and below the display provide access to the various configuration menus and processes. These menus are used to control the operation of the PQA300 and to make any configuration changes to the parameters that control the various modes of operation. You can remove the soft keys from the display by clicking in the bar at the bottom of the PQA300 screen. Click in the bar again to make the soft keys reappear.

---

**NOTE.** *If you click on a soft key to start a process and the configuration for that process is not correct, you will get an error message and the process will not start. Correct the configuration, and then the process will continue.*

---

**Soft Key Behavior.** Most of the main menu soft keys have left mouse button and right mouse button selections. A click of the left mouse button activates or toggles a specific feature. A small indicator in the soft key is turned on when the function associated with that soft key is active. A click of the right mouse button on the major function soft keys displays the configuration menu associated with the soft key. (A press and hold of the left mouse button for longer than about 1 second has the same result as clicking the right mouse button.) The soft key functions are shown in Table 2-6.

**Table 2-6: Soft key control behavior**

Soft key name	Left mouse button click	Right mouse button click
Generate	Activates or terminates a generate task	Displays the Generate Configuration menu
Capture (Start)	Activates or terminates a capture task Starts capturing a user sequence for striping	Displays the Capture Configuration menu
Measure (Set Region)	Activates or terminates a measurement task Sets crop limits for a defined sub region	Displays the Measure Configuration menu
Function (Learning)	Activates or terminates a function task Starts and stops a Learn Mode function creation	Displays the Function Configuration menu

**Table 2-6: Soft key control behavior (cont.)**

<b>Soft key name</b>	<b>Left mouse button click</b>	<b>Right mouse button click</b>
Print	Displays the Print setup menu	Displays the Page Setup menu
Summary/Detail/Graph/Video	Cycles through the measurement results displays. The label on the soft key changes to show the results type being displayed.	Displays a popup menu showing the results displays that you can select. Unavailable choices are grayed out.
Preference	Restores the user preference setup (any in-process activity is terminated)	Displays the Preference Configuration menu
601 Display	Activates or terminates the external monitor display	Displays the External 601 Display Configuration menu
Results	Activates or terminates a results display activity	Displays the Result Configuration menu
Playback	Activates or terminates a playback activity	Displays the Playback Configuration menu
Other	Accesses the menu choices of Video Controls on/off, View Graph Legend on/off, View Transcript, Working Directory, File Operations, Update Database, Display Settings, Hardware Settings and Diagnostics, Save Values to Disk, Help, Minimize, and Exit.	Same as a left mouse button click

**Text Editing and Keyboard Controls**

The instrument keyboard is used to enter file names, directory locations, and various alpha or numeric variables. Any parameter field in the configuration menus permitting alpha or numeric entries can be edited using the edit features of the keyboard. Use the tab and shift-tab keys to select the button choices in the configuration menus. Use the enter key to activate a selected button (a small outline is shown around the button label when the button is selected). The Esc button exits an active configuration menu.

**Display Behavior**

All the PQA300 displays are in windows. In each of the four measurement views (summary, detail, graph, video) the sequence name, the measurement name (PQR, PSNR), and the format (601-525, 601-625, NTSC, NTSC No Setup, or PAL I) are displayed for the current test sequence.

**Video Sequences.** You can select live video, a captured video sequence, or a stored video sequence file to display using the menu choices associated with the playback configuration menu (refer to *Playback Configuration Menu* in the *PQA300 Picture Quality Analysis System User Manual* for configuring information).

**Results Displays.** You can view measurement results as a summary, as field-by-field details, as a graphical display, or as a video picture difference sequence. You can use the measurement results to determine overall picture quality or to examine specific fields of a video sequence for problem areas.

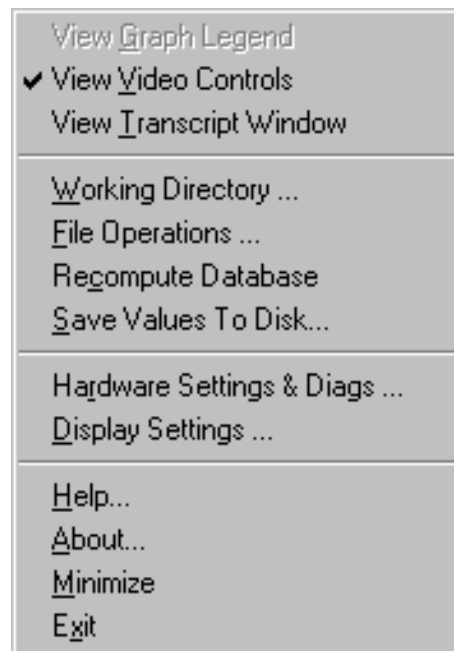
**External Display.** You can connect a serial digital component video monitor to the 601 digital picture monitor output to view the PQR and PSNR picture difference maps at full resolution. In addition, you can view input signals and captured signals in full digital component video resolution. You can configure the external digital picture monitor display in a display configuration menu. Access the external display configuration menu by clicking the right mouse button on the 601 Display soft key to bring up the menu window.

### Configuration Menus

All the configuration menus are accessed by a click of the right mouse button (a long click and hold of the left mouse button also works). Refer to *Soft Key Controls* on page 2-9. Refer to the *PQA300 Picture Quality Analysis System Service Manual* for a description of the configuration menus and the user configuration choices.

### Other Soft Key Choices

Press the Other soft key to access some operation supporting functions. The choices are shown in Figure 2-4. Refer to the *PQA300 Picture Quality Analysis System User Manual* for further information on the Other soft key.



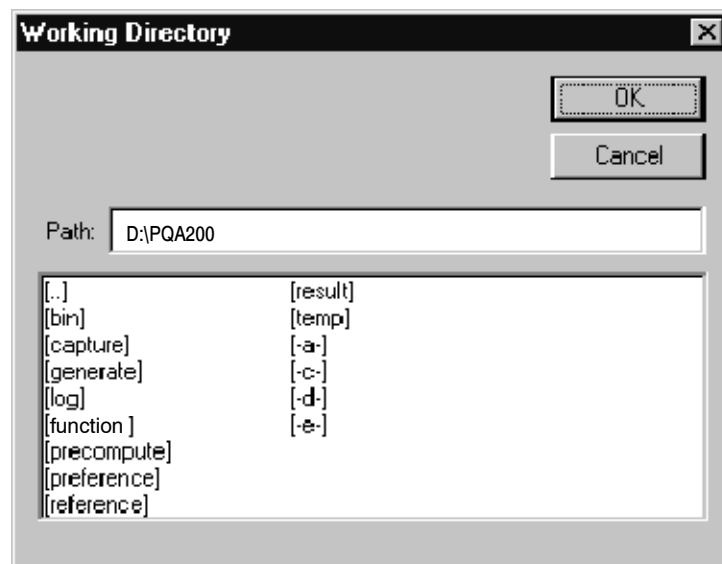
**Figure 2-4: Supporting functions under the Other soft key**

**View Graph Legend.** The graph legend is available for display only while graph results are displayed. Turn the legend on or off using the selection on the Other soft key or with the Legend soft key in the graph display.

**View Video Controls.** The Video Controls are available during playback operation and when viewing video of either test sequences or maps. Turn it off by deselecting the choice in the Other soft key choices.

**View Transcript Window.** The transcript window lists the application activities that have occurred and are occurring for use as a debugging tool. Use the scroll bar to move through the list of events if necessary.

**Working Directory.** The PQA300 application searches for its files in the working directory. Use this window to select the working directory shown in Figure 2-5 by double clicking on a directory name. Double click on the [..] symbol to go up the directory tree one directory at a time. You can also enter or edit the path directly in the Path edit field. To save your changes, either select the OK soft key or press the enter key. The Working Directory window closes.

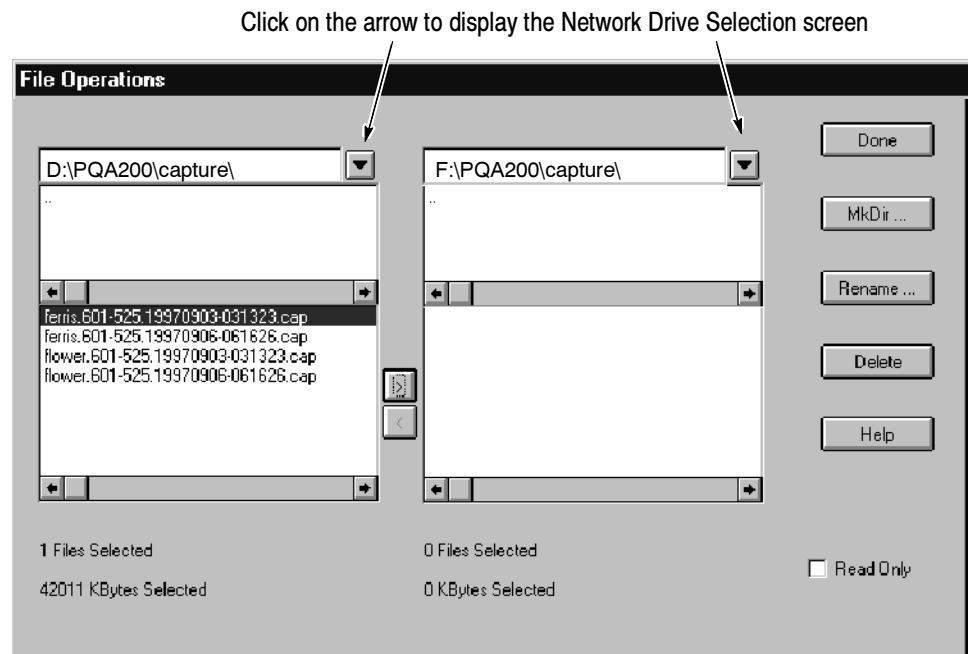


**Figure 2-5: Working directory selection screen**



**NOTE.** The working directory must contain all the PQA200 subdirectories. The application software expects to find the files in specific directories. If you select a working directory that is not structured as needed for the application, the supporting files for generate, results, and so on, will not be available. On the instrument, the appropriate working directory is D:\PQA200.

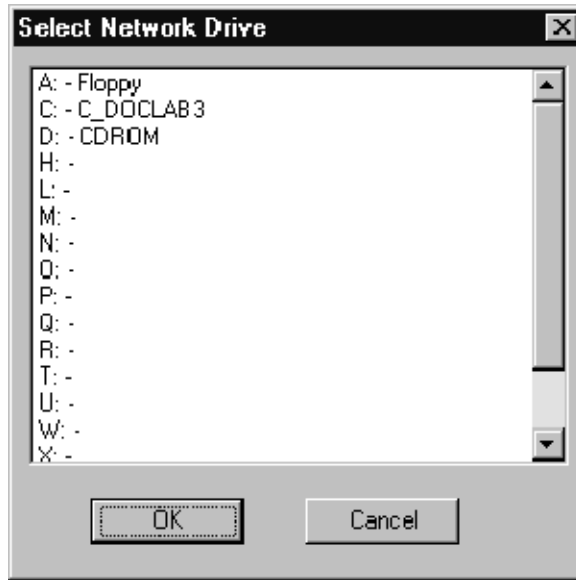
**File Operations.** Use the File Operations screen to move files between the internal hard drive and the 1.44 Meg disk drive and to retrieve files from the CD-ROM drive. The dialog box for the File Operation menu is shown in Figure 2-6. Move down the directory tree by double clicking on a directory name in the top window. Select a file by clicking on the name in the bottom window. Move back up the directory tree by double clicking on the “..” selection.



**Figure 2-6: File Operations menu under the Other soft key**

**Select Network Drive.** Access the Select Network Drive dialog screen (shown in Figure 2-7) by clicking on the selection arrow next to the directory label field (shown in Figure 2-6).

The choices include the hard disk drive, the floppy disk drive, the CD drive, and any available network drives. Select both the source directory and target directory for file transfers as appropriate. Files can be transferred in either direction between currently selected drives.



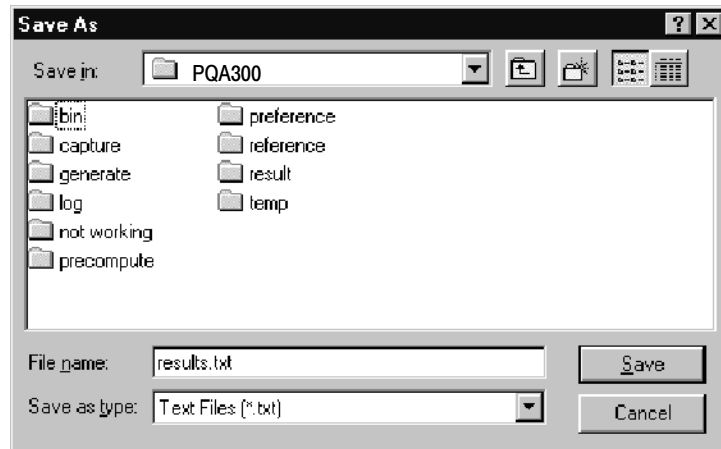
**Figure 2-7: Select Network Drive menu**

**Recompute Database.** As user references, alias-named test sequences, and user sequence files are captured, the information about the names assigned to the files and the references that are associated with the files is stored in text files in the PQA200 bin directory. To regain disk space, delete unused user references, alias-named test captures, and user-named sequences.

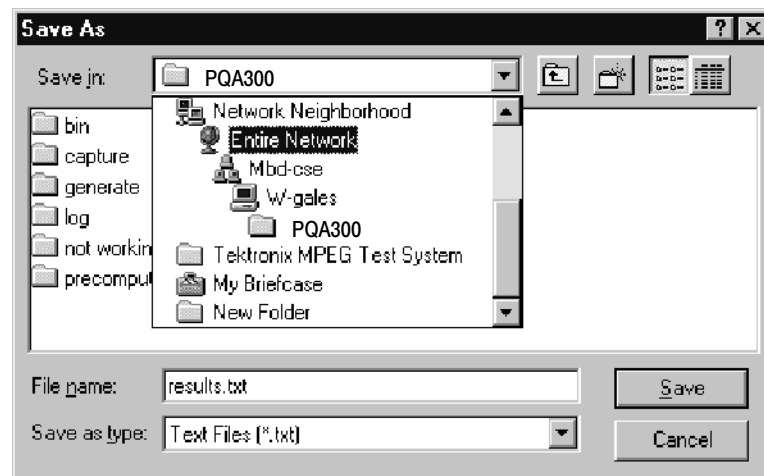
Use the Recompute Database selection as part of the disk-space clean up after deleting a large number of user files or after adding user files from another PQA300. When the database is recomputed, the system updates database files to delete associations that are no longer in use and adds new associations of the user files copied to the PQA300.

**Save Values to Disk.** This selection saves the summary and detail results of the current results displays to a text file on the selected disk drive. The Save As menu shown in Figure 2-8 is displayed when you select the Save Values to Disk feature. You can name the file by clicking in the file name field and editing the default name. You can use the Save in: choice to select a drive where you want to save the files.

Click the arrow key in the Save in: edit field to display the network selection menu shown in Figure 2-9. In this menu you can select any drive on the network you have access to for saving the results text files. The Help ? in this menu accesses the instrument What's This help for information on the choices in the menu.

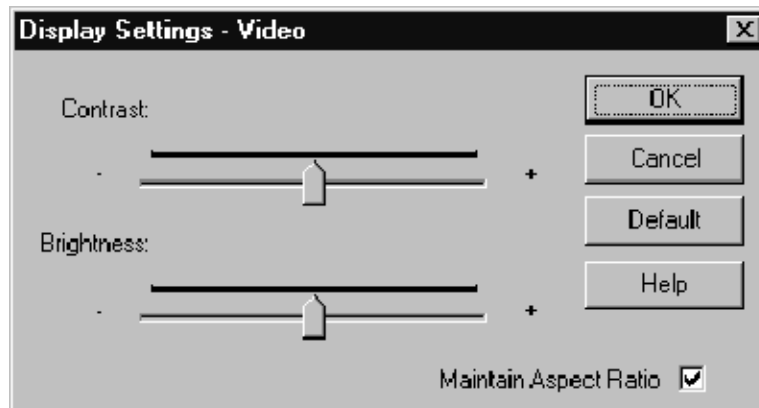


**Figure 2-8: The Save As menu for saving results text files**



**Figure 2-9: The network selection menu for choosing the location to store results text files**

**Display Settings.** Click on the Display Setting selection in the Other menu choices to show the Display Settings controls (see Figure 2-10). The display setting controls are used to adjust the brightness and contrast of the maps and video displays individually. The controls adjust the display that is active when the Display Settings menu is activated. The menu label changes to indicate the active display type (Video, PQR Maps, or PSNR Maps).



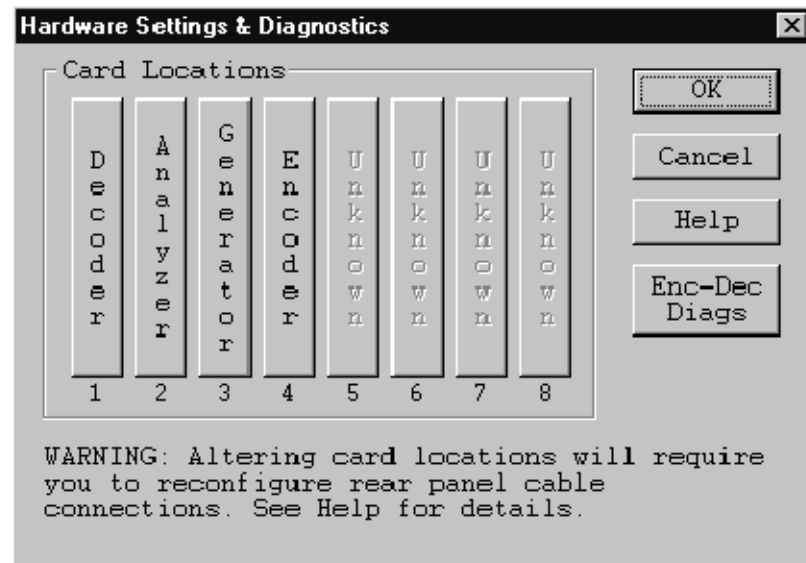
**Figure 2- 10: Display settings controls**

Select **Maintain Aspect Ratio** to have map or video displays keep the same vertical-to-horizontal ratio when you resize the PQA300 window. If **Maintain Aspect Ratio** is not checked, the map and video displays resize in the same proportions as the PQA300 window.

**Hardware Settings.** The controls for setting the slot locations for the analyzer DSP and generator DSP modules are in the **Hardware Settings** menu (shown in Figure 2-11). Click a slot in the configuration menu to switch between **Analyzer**, **Generator**, and **Empty** (undesigned). If you switch the location of the **Analyzer** and **Generator**, you must reconnect the rear panel signal cables appropriately.

The default configuration is:

- Slot 1: Option 01 composite decoder (if installed).
- Slot 2: The analyzer DSP.
- Slot 3: The generator DSP.
- Slot 4: Option 01 composite encoder (if installed).
- Slot 5: Video circuit card. The video card is not a recognized PQA300 system module and is shown as **Unknown** in the **Hardware Settings** menu.

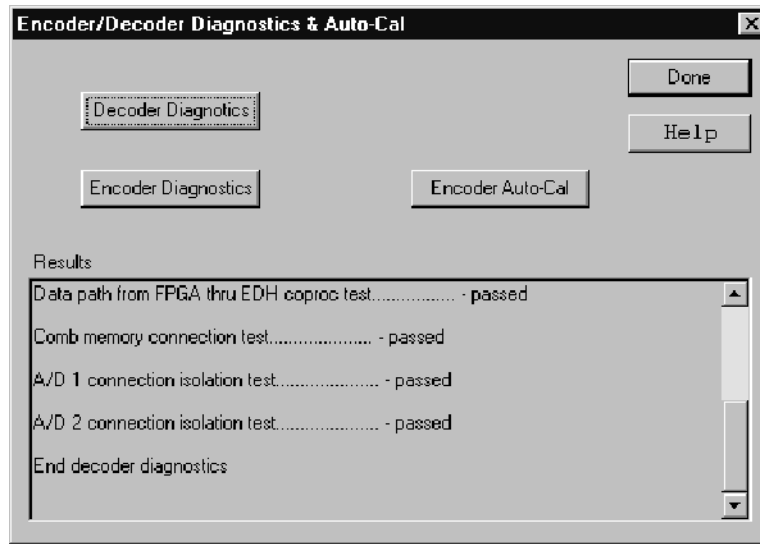


**Figure 2-11: Hardware settings menu**

**Encoder/Decoder Diagnostics.** Click the Encoder/Decoder soft key selection in the Hardware Settings menu to access the Option 01 user diagnostics (shown in Figure 2-12). The diagnostic tests for each module are separately selectable. They provide pass/fail testing of the Encoder and Decoder module circuitry. When you run the tests, the results are displayed in the Results box with the name of the test and the pass or fail result of the test. The Encoder Diagnostics need more time to complete than the Decoder diagnostics. Use the scroll bar to view the completed test results.

**Encoder Auto-Cal.** The automatic calibration routine compensates the adjustments of the encoder module for temperature changes and aging. Typically, you would use this feature about every six months to maintain optimum encoder operating. Another good time to use it would be if the Encoder diagnostic tests start showing soft failures (failures that occur with temperature changes). The PQA300 must be allowed to completely warm up (about 20 minutes) before the using the automatic calibration feature.

**Help Menu.** The PQA300 Picture Quality Analysis System has a Windows based help system. You can obtain general help on the PQA300 using the Help choice in the Other soft key selection list. The Help Topics contents screen shown in Figure 2-13 is displayed. You can use the contents help screen to navigate through the user interface for information entirely within the help system.



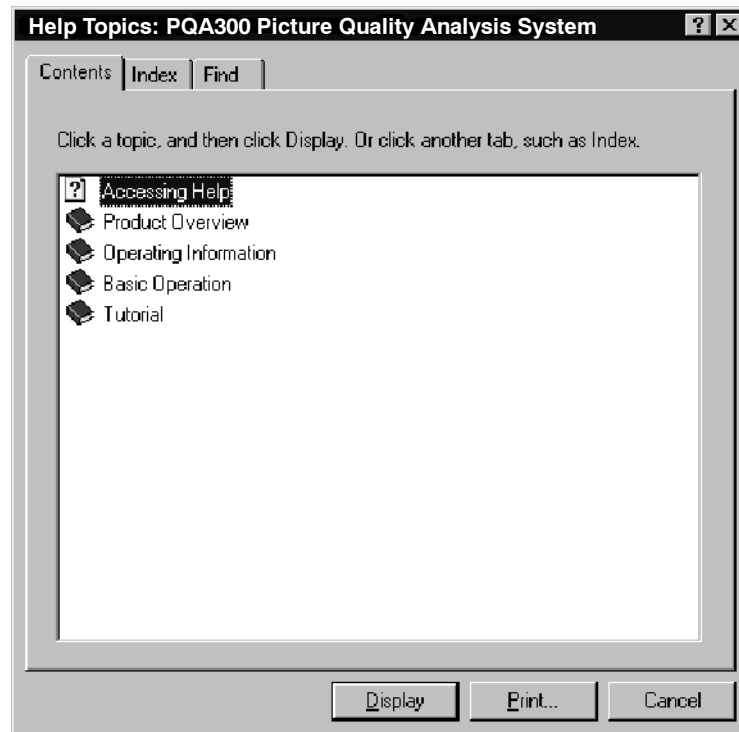
**Figure 2- 12: Encoder/Decoder diagnostics and Encoder Auto-Cal**

Use the mouse to select a content area and double click to open the book. When you see a topic you want to read about, either double click on the topic or select Display in the Help Topics screen to display the help about that topic.

Select the Index tab to do a search by topic or select the Find tab to do a search of words in the help file. Refer to the Windows NT documentation for more information on using a Windows-based help system.

Click on the Help button in a configuration menu to enter the help system at a screen related to that configuration menu.

**Minimize, Exit, and About.** The Minimize choice reduces the PQA300 application to an icon, but leaves the application running. Exit terminates the application and saves the current configuration settings in the shutdown preferences preset file. If the shutdown preset file is selected either as the startup preset or as the preset to be restored when the Preference soft key is clicked, the configuration settings at the last application exit will be restored. The About choice displays the copyright information for the application.



**Figure 2-13: Help system contents screen**

## Messages and Prompts

Messages and prompts inform you of certain actions. See *Appendix F* for a list of Option 01 and system error messages and their meanings.

**Progress Indicator.** In the status bar at the bottom of the display, a progress indicator, shown in Figure 2-14, shows the name of the activity that is occurring and its progress. If multiple actions are occurring, for example obtaining the results for several test sequences, the progress bar will restart with each new action. When the final action has finished, the progress bar is removed, and the action line states that the action has completed. The transcript window also displays the action that is occurring in text format.



**Figure 2-14: Progress indicator shown across the bottom of the display**

**Capture Mode.** Several different Capture Mode dialogs are displayed, depending upon the choices made in the Capture Configuration menu. Activity messages are displayed in the status bar. The messages indicate such activity as waiting for a sequence, capturing, saving, and time out. The progress indicator shows the state of the named activity when appropriate.

**Measure Mode.** During a picture quality measurement, the status bar displays the progress of the measurement. To the right of the progress indicator, you will see the measured value for the field, the peak measurement that occurs during the measurement, and a field indicator showing the current field being measured. The peak value found as all the fields are measured is held when the measurement is finished. The same messages are displayed when a measurement results file is restored for viewing.

**Configuration Errors.** If you click the left mouse button on any of the PQA300 function soft keys that have associated configuration menus, you will get an error message if the configuration is incorrectly set up to produce the action you selected. For example, if you click on the Results soft key and there are no results selected, an error message displays.





# **Theory of Operation**



# Theory of Operation

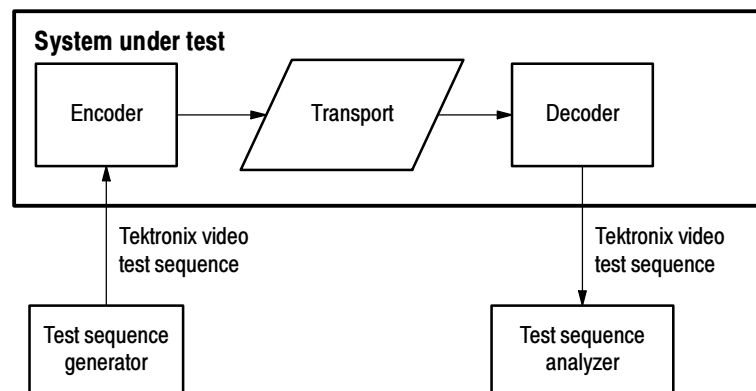
The PQA300 Picture Quality Analysis System is a picture quality measurement instrument that produces repeatable, objective measurement of picture quality impairment.

Measurement results are based on a frame-by-frame comparison between the original (reference) video material and the reconstructed video obtained after the digital data has been processed by a variety of methods. For PQR measurements, both the reference sequence and the captured test sequence are applied to an algorithm that predicts how a human viewer would perceive the changes in the video due to the system under test. This process normalizes the two sequences. After normalization, the two sequences are compared to develop the JND numbers from which the PQR rating is determined.

For the PSNR comparison, the PQA300 system directly determines the differences introduced by the processing system (impairments, artifacts, or degradations). These differences are used to calculate the PSNR value. The PSNR number is a raw data comparison of the two sequences without regard to how a human viewer might perceive the picture quality.

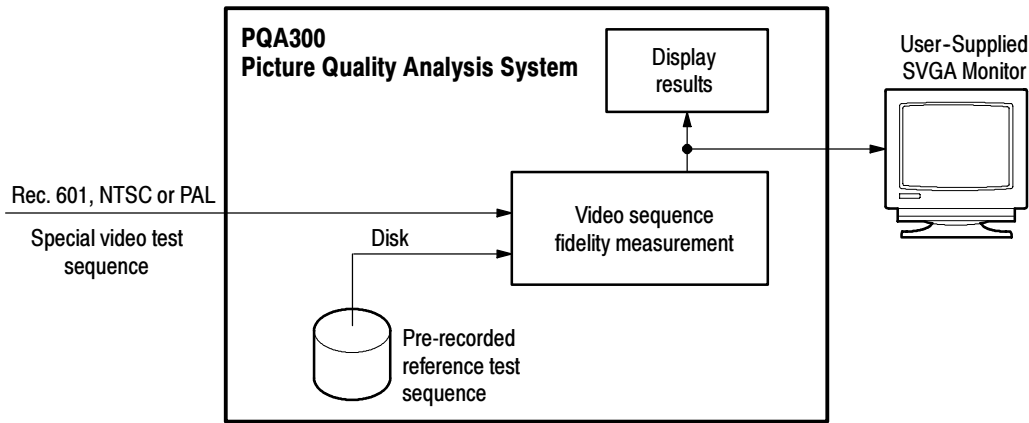
## Functional Operation

The PQA300 Picture Quality Analysis System provides quantitative objective measures of degradation in quality of video sequences as they are transported. Compression coding-decoding may be employed in such transport. How the PQA300 Analyzer is used is depicted in the following diagram.



**Figure 3-1: Test setup for direct measurement of system fidelity**

To measure impairments a transport system causes, special video test signals with calibration striping are used. The striping is encoded with the test sequence identification and frame indicators and provides the information needed for shift correction and normalization of the captured sequence. The PQA300 analyzer compares the normalized captured sequence with a stored reference sequence and derives the picture quality measurements. The functional operation of the PQA300 system is shown in Figure 3-2.



**Figure 3-2: Functional operation diagram**

The PQA300 system receives transported video sequences encoded in serial Rec. 601, NTSC, PAL or S-Video. The system must have a copy of the original test sequence stored internally. Video sequence fidelity measurements are performed by comparing the normalized transported sequence to the copy of the original sequence. Live incoming video can also be displayed to monitor the transport stream. Visual assessment of quality degradation can be made by displaying selected segments of the original test sequence and the transported test sequence, along with associated difference maps, on an optional external 601 digital monitor display.

### Hardware Implementation

The analyzer, generator, encoder, and decoder card are implemented in plug in modules on a PCI bus, connected to a PC-NT system through a PCI bridge. The PC-NT system has enough memory, disk space, and mainframe computing power to provide for smooth user interface support and data flow. The user interface is supported with the display/mouse/keyboard of the Option LC. The hardware functionality is divided between the standard analyzer and generator DSP boards and the optional NTSC/PAL composite video encoder and decoder boards.

The analyzer DSP board performs video processing. Its functions are test sequence recognition and capture, sequence normalization, application of visual model filter algorithms, and composing the output for visual inspection of

transported and original test sequences on an attached SVGA computer monitor. The I/O to the DSP board is implemented in serial 601 format. If only serial 601 input is required for the instrument, the NTSC/PAL composite video option modules can be omitted.

When installed, the NTSC/PAL decoder board 601 serial digital output is linked to the analyzer DSP board using an active loop-through input connection. If the loop-through is not continued to a 75  $\Omega$  system, the active loop-through need not be terminated. The 601 output of the generator DSP is connected to the composite encoder module to a 75  $\Omega$  terminated SMB input connector.

You can use an external encoder and decoder to make composite measurements. When testing against the 601 digital reference, you will see the total effects of the encoder, decoder, and the system under test. You must use the Tektronix Option 01 encoder and decoder to capture a composite testing reference for the comparison to de-embed the encoder and decoder effects from the measurement.

Composite video sequences have a different color phase for each field. All possible color phases for the selected format (NTSC or PAL) are sent. If a captured composite test reference is selected as the reference sequence, the Option 01 decoder looks for the sequence with field color phasing that matches the captured reference color phasing and signals the analyzer to capture the sequence. The correct color phase must be captured so that a correct comparison can be made. Refer to *Creating a Testing Reference* in the *PQA300 Picture Quality Analysis System User Manual* for more information on testing against a captured reference.

**Data Flow** The data flow occurs in several phases. These are as follows:

- Waiting for the test sequence
- Capturing and saving the test sequence
- Performing measurements and saving the results
- Displaying results

**Waiting for a Sequence.** In this phase, the PQA300 analyzer is monitoring the input and waiting to recognize the presence of an embedded test sequence.

The serial digital signal arrives at the DSP board at 270 Mb/s. The arriving video fields are scanned in real time for the presence of a keying pattern embedded into the active video portion of a PQA300 system video test sequence. In the mode where the PQA300 system is looking for a specific pattern (as opposed to any valid test sequence pattern) downloading of the copy of the corresponding original sequence into DSP memory begins even before the arrival of the test sequence is detected.

**Capturing the Test Sequence.** When the arrival of the specified test sequence is detected, two seconds of active video are captured into the DSP board memory and saved to the server hard disk drive.

**Performing the Measurement.** In this phase, the captured test sequence and the reference sequence are compared, passing them through a variety of DSP filters and deriving measures using various algorithms. The results are communicated to the server for display and archival.

**Displaying the Results.** Finally, the statistics of measures are displayed. This process also allows for qualitative visual comparison of incoming and reference test sequences by playing them into a high resolution external serial digital video monitor.

## Functional Block Overview

The PQA300 system is shown in block form in Figure 3-3. The composite video option is included in this discussion. A Rec. 601 digital video signal source from either the generator or user-supplied equipment is applied to a system under test. The system under test injects its output into the PQA300 system analyzer DSP Main loop-through input BNC connector. When a test sequence is recognized, the sequence is captured by the DSP module.

The JND and/or PSNR differencing algorithms compare the captured video test sequence with the previously stored matching reference test sequence obtained from the server hard disk drive. The field-by-field differences between the two sequences (artifacts of the processing by the system under test) are determined.

For many applications, the inputs are analog composite video signals. In that case, the generator DSP output is fed to an encoder that converts the Rec. 601 serial digital signal to composite video (either NTSC or PAL as selected by the user). The analog signal is then injected into the system under test. The resulting output from the system under test is then fed to a composite decoder to be converted back to a serial digital signal for application to the analyzer DSP. The composite encoder and decoder may be user provided equipment or the modules provided with the Option 01 Composite Video option of the PQA300 system.

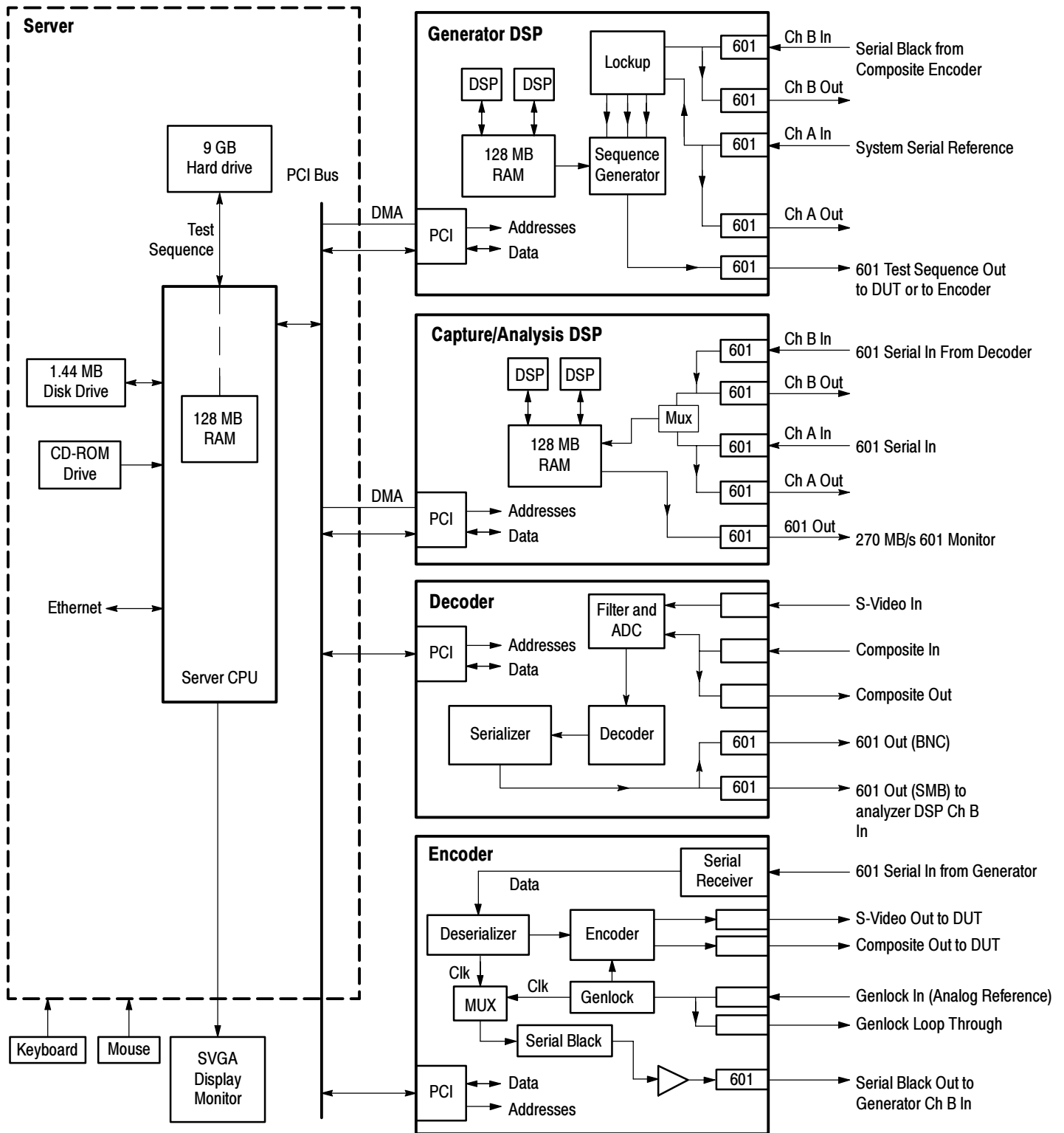


Figure 3-3: PQA300 Picture Quality Analysis System block diagram with encoder/decoder option

### Composite Generator Configurations

The composite generator consists of the generator DSP and the composite encoder (Option 01). You have several options regarding synchronization of the generator to the encoder: Black Burst Lockup, Serial Video Lockup with the generator in the free-run mode, and Serial Video Lockup with the generator synchronized to an external serial digital video reference.

**Black Burst Lockup.** To use an analog composite signal to the encoder for genlock, make the connection between the encoder serial black out connector and the generator DSP Ch B In connector as shown in Figure 3-4. Connect the analog composite signal used as a reference to one of the Genlock loop through BNC connectors. You must connect the Genlock loop-through output to a 75 Ω system or terminate it with a 75 Ω BNC termination.

If you choose not to connect a genlock signal to the encoder module, the serial black output from the encoder continues but becomes invalid. When the serial black out signal is not a valid synchronization signal or if you are not going to use Black Burst lockup, you must disconnect the serial black signal from the generator DSP Ch B In connector. The configuration is then valid for the Serial Video lockup mode of composite generator operation.

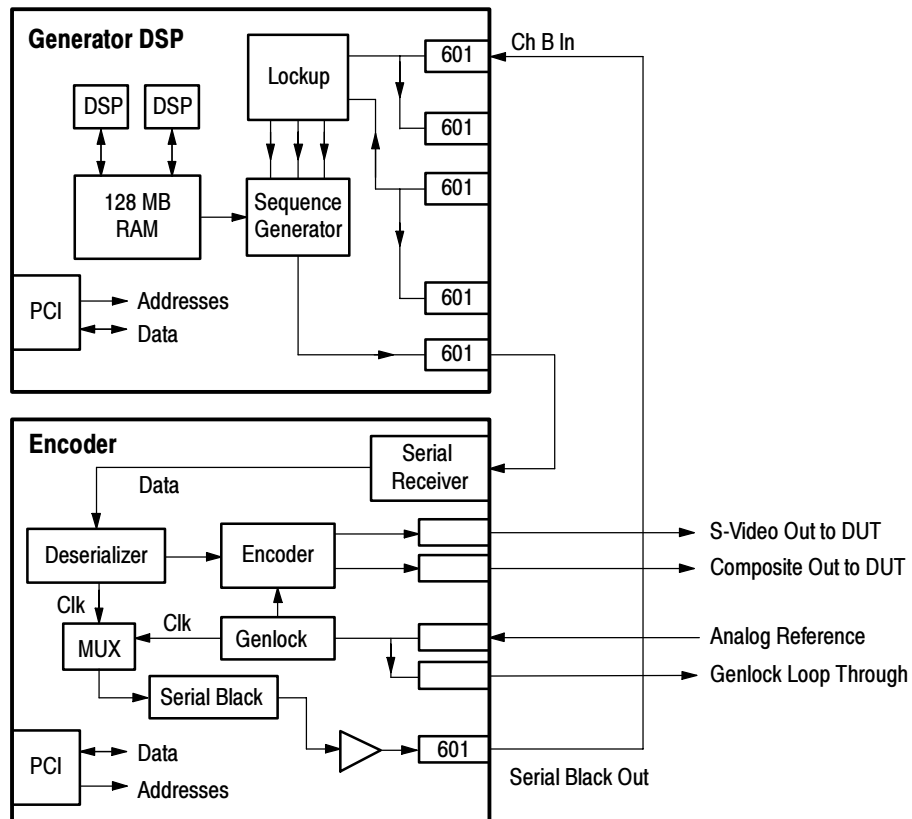
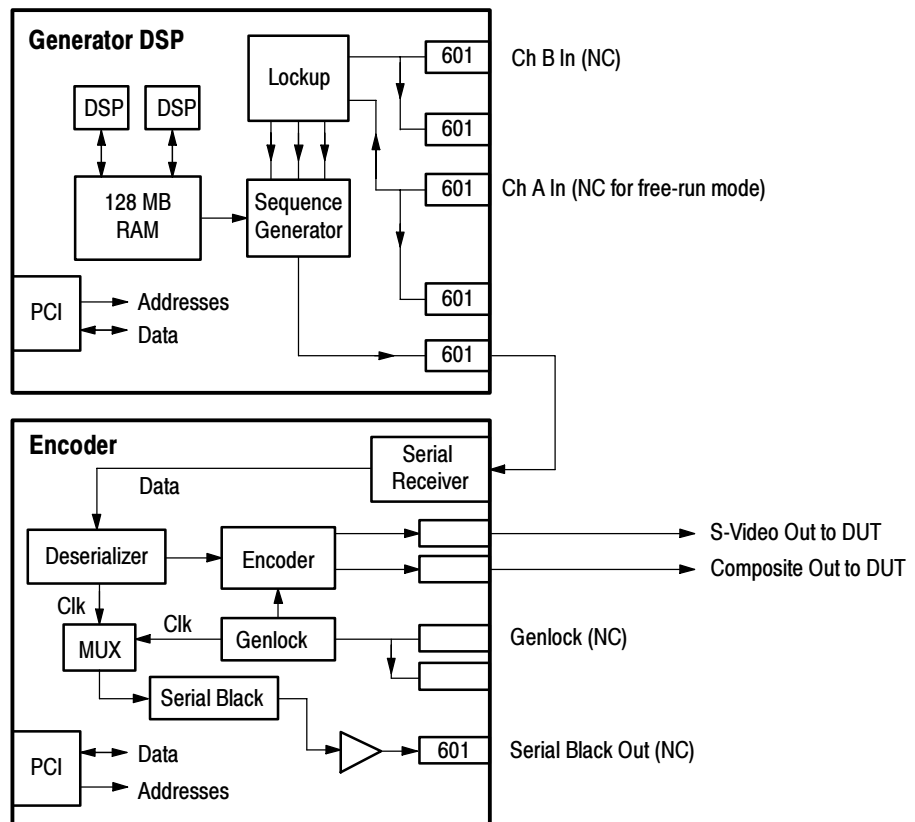


Figure 3-4: Composite generator with external analog reference



**Serial Video Lockup.** When connected as shown in Figure 3-5 the serial digital video signal from the generator is the source of the synchronizing signal to the encoder board. You can choose to allow the generator DSP to free run on its internal reference or you can synchronize the generator DSP to a serial video reference. The external serial digital is connected to the generator DSP Ch A In BNC connector. To avoid a synchronization conflict, do not connect a serial digital video signal to the generator DSP Ch A In connector when you use the serial black output signal of the encoder for genlock.



**Figure 3-5: Composite generator free-run mode**

### Composite Analyzer Configuration

The composite analyzer consists of the analysis DSP and the composite decoder. A connection diagram is shown in Figure 3-6. Either composite video or S-Video input signal is accepted (not both at the same time). You must connect the composite out loop through signal to an external 75 Ω system or terminate it with a 75 Ω termination.

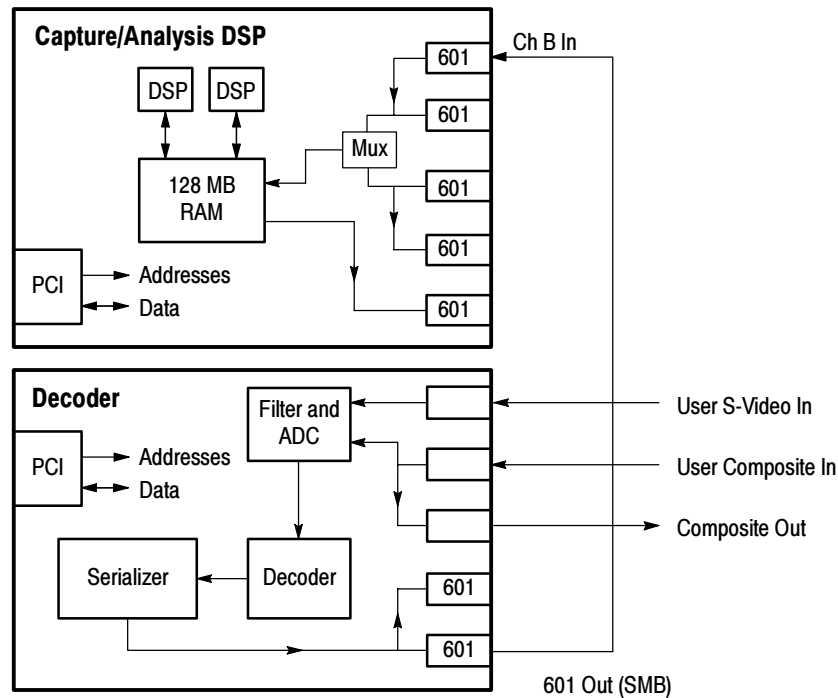


Figure 3-6: Composite analyzer block diagram

### DSP System Operation

The DSP card processes video data using two on-board DSP processors. The board has a PCI interface, two serial digital video input interfaces with active loop-through outputs, and a serial digital video output interface. The PCI interface is for control, video data, and DSP program code download. The serial digital video interfaces are for real-time capture and playback of digital video.

The DSP module can output processed program output video in Rec. 601 serial format. The 601 Out connector of the generator DSP provides test video sequences to a device or system under test. The 601 Out connector of the analyzer DSP provides serial digital component video that can be viewed on a high resolution external digital video monitor.

The DSP system is made up of two DSP processors, a 128 MB of single-cycle (SDRAM) main memory, a boot ROM, a 64 kB shared memory, some control

and status registers, a PCI FIFO (first in, first out), and an I/O Video ASIC. Video from the ASIC (application specific integrated circuit) is transferred in 1kB blocks into memory to form *fields*. The analyzer and generator DSP modules are identical. Their operation as an analyzer or as a generator is software controlled.

### Serial Digital I/O Block Description

The serial digital I/O system comprises two serial input connectors (Ch A In and Ch B In) and associated deserializers, two serial active loop-through connectors (Ch A Out and Ch B Out) and associated amplifier, a serial output connector (601 Out) and associated serializer, and a clock generator. The Ch A In, Ch A Out, and 601 Out connectors are BNC. The Ch B In and Ch B Out connectors are SMB. A simplified block diagram of the I/O section of the DSP module is shown in Figure 3-7.

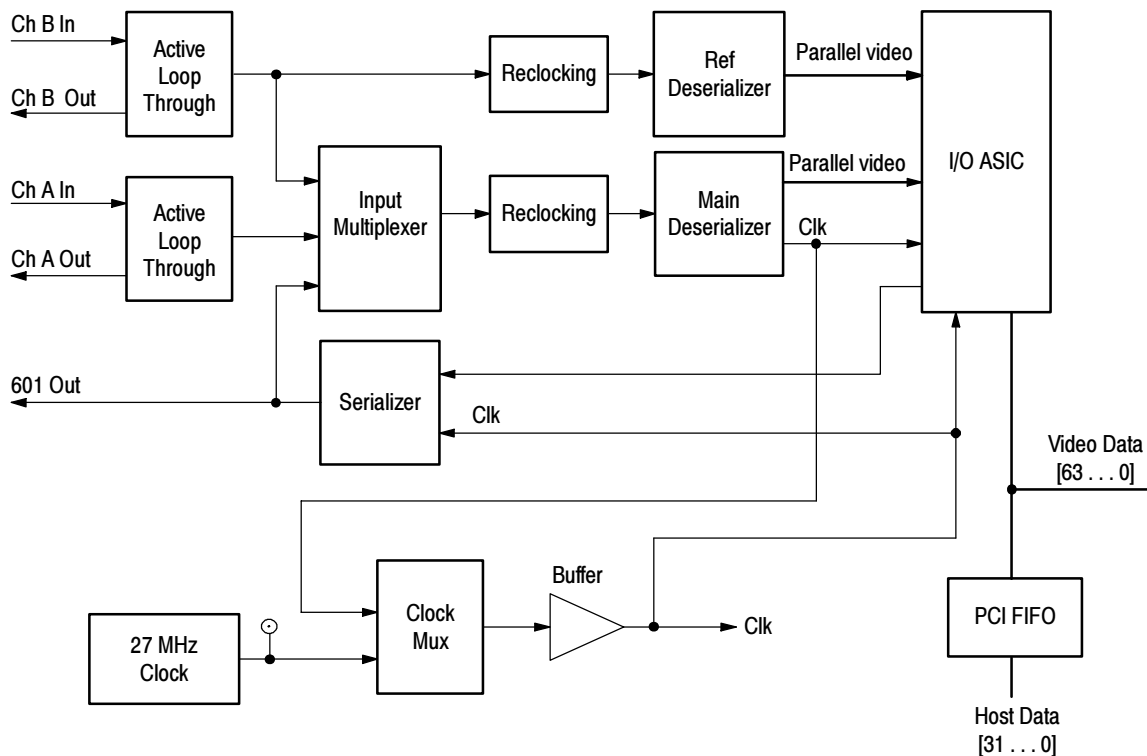


Figure 3-7: Digital signal processor module I/O section simplified block diagram

**Ch A In.** The Ch A In connector feeds a cable equalizer through a return-loss matching network. A carrier detect output from the cable equalizer is fed to the status port so the system can determine if an input is present. The software looks at the carrier detect bits before attempting to use either the Ch A In or the Ch B In input as the signal source.

The output of the cable equalizer drives the active loop-through output driver and the input multiplexer. The other inputs to the input multiplexer are from the other channel and from the output (to allow loopback for self-test).

Only the primary input to the I/O ASIC has timing extraction. There is a 3:1 input multiplexer into the main deserializer. This allows either input to be used in single channel mode with the data coming through the main deserializer. The second deserializer will only be active in two channel mode. If both input channels are being used simultaneously, they must be identically timed and synchronized to the same clock. The third multiplexer input is a feedback from the serializer that is used for diagnostic testing.

**Serial to Parallel Converter.** The output of the input multiplexer goes to a reclocking circuit that drives a serial-to-parallel converter (deserializer). The serial-to-parallel converter also does the descrambling. The circuit outputs are parallel video and clock. Source terminations are used in the lines to the buffer ASIC. The clock goes two places, to the I/O ASIC and to the clock multiplexer.

No precision clocks needed in the DSP section; the I/O functions drive the clock source decisions. The input locks to the incoming stream provided it meets SMPTE 259M specifications. There are no circuit provisions made to lock to very jittery input streams or to attenuate jitter on the active loop-through outputs.

**27 MHz Oscillator.** An internal 27 MHz oscillator is used when there is no external video signal supplied. The 2:1 clock multiplexer is under software control. There are multiple clock outputs to allow each DSP in the module to have a dedicated clock line.

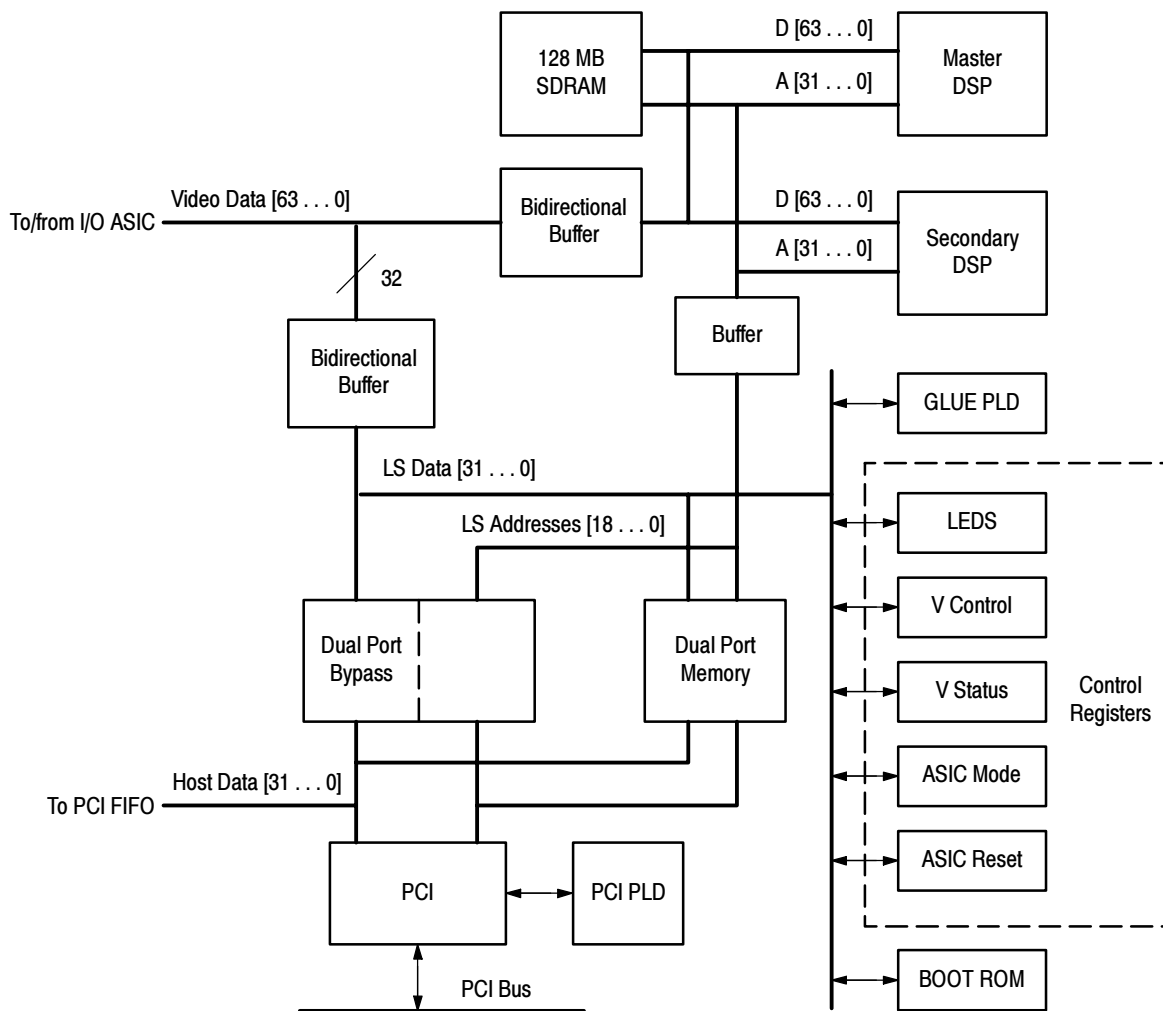
In internal clock mode (also referred to as free-run mode), the program output must meet the SMPTE 259M frequency accuracy and jitter specifications. To meet these requirements, an accurate crystal oscillator is used as the internal clock source. The oscillator is a 27 MHz  $\pm$  1ppm TCXO. The oscillator drives the clock multiplexer as one of the two possible inputs. The output of the clock multiplexer drives a clock buffer.

**Decoder Valid.** Status bits from the reclocking circuit and the serial-to-parallel converter are combined to derive the main decoder valid signal (MAIN-DECVAL). This signal is checked by the software before attempting to use the clock or video from the channel A input. If the system is deriving the clock from this input, and MAINDECVAL goes low, the clock multiplexer automatically reverts to the internal clock source.

**Output.** The output serializer drives a connected cable directly. One output of the serializer is fed back to the input multiplexer to for use in a loop-back self-test.

**DSP Block Description**

The DSP devices are two TMS320C80 microcircuits with five processors each. These processors share 128 MB of fast SDRAM. The analyzer DSP accepts serial digital component video inputs that adhere to ITU Recommendation 601 coding formats. The DSP does the signal matching and normalization of the captured video sequence prior to making the PQR calculations relative to stored references. PSNR picture difference calculations are done by the server CPU after normalization by the DSP. A simplified block diagram of the DSP portion of the module is shown in Figure 3-8.



**Figure 3-8: Digital signal processor module DSP section simplified block diagram**

### **PCI Bus Interface**

PCI is the bus interface between the plug in modules and the server. The PCI system is made up of a PCI interface chip, 64 kB of Dual Port shared memory, a discrete status register, PCI FIFOs, and a PCI control circuit (PLD). The DSP system can generate interrupts onto the PCI bus. The PCI system can also generate interrupts to the DSP system.

The PCI system provides setup and control messages to the DSP processors through the Dual Port shared memory system. DMA transfers that bypass the Dual Port shared memory can be initiated by the PCI host or by the on-board DSP processors.

### **Boot ROM**

The Boot ROM is a 4 Mbit Flash EPROM, 8 bits wide. It contains the boot steps used to start up the DSP module when the server is started. The DSP start up diagnostics are contained in the Boot ROM.

The Boot ROM is not programmable on board the module. It is installed in its socket after programming. The programming stored in the Boot ROM performs the following functions:

- Initializes all hardware devices (for example, it resets the I/O Video ASIC)
- Initializes the DSP processors
- Performs minimal diagnostics:
  - Control port read/write
  - Quick Dual Port Read/Write
  - Quick SDRAM Read/Write

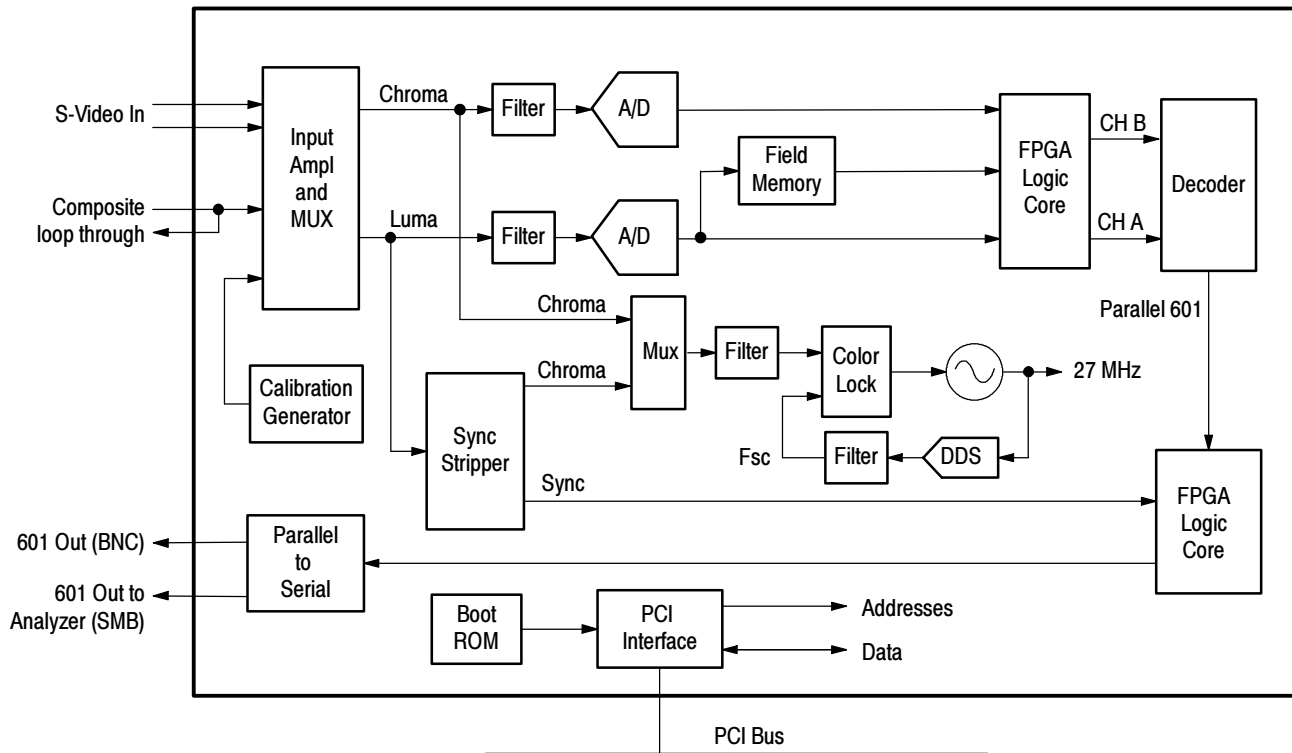
After the reset, the DSP processors wait for a signal from the server (PCI) to start download operation. Once the download is complete, the DSP vectors to the starting address of the downloaded programming.

## **Composite Decoder**

The composite analyzer is formed by a DSP and an optional composite video decoder module that accepts composite video or S-Video and converts it to 601 video at 270 MHz. The decoder block diagram is shown in Figure 3-9. As are the other modules, the decoder is a plug-in circuit board that communicates with the server and the analyzer DSP through the PCI bus.

### **Input**

The decoder module input accepts standard level analog video. Input can be composite or S-Video. The input consist of clamping circuitry, buffering, and multiplexing switching. Composite video input is buffered and goes to the Luma output that is applied to the sync stripper. With an S-video input signal, the separate chroma and luma video information are buffered outputs. A calibration signal is applied to the third input to the multiplexer.



**Figure 3-9: Decoder simplified block diagram**

### Calibration Generator

The calibration circuitry applies accurate 2 and 3 volt DC levels to the video input circuitry. The FPGA (field-programmable gate array) device averages the resulting values from the converters and compares them to an internal constant. The results of the comparison drives an LED indication circuit to show if the relative A/D output value is high or low. There is also a diagnostic mode signal, a 2 V ramp, that can be applied to the video output amplifiers for testing. Calibration and diagnostics modes are normally manually selected by setting the mode switch on the board. However, when the mode switch is set to the run position, the diagnostics routines can drive the DAC circuitry for closed-loop testing.

### Sync Stripper

The sync stripper ASIC outputs a signal during the sync portion of the video that is used for coarse timing. The input clamp circuit must be running for this sync stripper to work correctly. The chroma output is applied to 2:1 MUX that selects between the S-Video chroma and the chroma stripped from the composite video signal for the color lock circuit. The sync is applied to the FPGA device.

- A/D Converters** The analog inputs are attenuated to fill the A/D converter full scale range and are anti-alias filtered for application to the A/D converters. The output of the A/D converters are buffered then decimated by half-band filters before being applied to the decoder device. When converted to 601 format, the standard video input maps into decimal 16 to 235 output levels in 8-bit mode and 32 to 470 levels in 9-bit mode. Signals with lower amplitudes will result in reduced decoder accuracy and signals exceeding the standard amplitude by a certain amount are clipped.
- Conversion clocks are derived from a color lock circuit that compares burst from the input to an Fsc (subcarrier signal) developed by a DDS (direct digital synthesizer) device running on the 27 MHz oscillator frequency.
- Decoder** The Ch A and Ch B decoder inputs are 10-bit data from the FPGA. The standard operating mode of the decoder uses an adaptive notch / 3-line comb filter. The field memory stores a field or frame of data used to develop the optional temporal filtering. Luminance data always goes to channel A of the decoder device. Channel B input can be the chrominance (S-Video mode) or delayed luminance for field and frame comb filter modes. The decoder output is fed back to the FPGA device for rounding, dither, and clipping.
- FPGA** The input and output of the decoder device goes to a field programmable gate array (FPGA) device that handles switching, clipping, and dithering to reduce truncation effects. The FPGA device is programmed with the logic to handle the operation of the decoder module. Operating modes of the decoder module are set by filling the appropriate registers on the decoder board through the PCI bus at the time a decoder operation is started.
- Color Lock** The Chroma portion of the clamped video or the chroma from the S-Video signal is applied to a Color Lock ASIC that controls the phase of the 27 MHz VCO (voltage-controlled oscillator). The VCO output is then used throughout the decoder module as the clocking signal. The 27 MHz clock signal also drives a circuit (DDS - direct digital synthesizer) that develops the Fsc (subcarrier frequency). The Fsc circuit is reset every color frame to correct for any slight frequency errors. The Fsc output completes the phase-lock-loop back to the Color Lock ASIC.
- Parallel to Serial Converter** The data bits are serialized in Rec. 601 format and applied to the 601 Out connector on the rear panel of the decoder module. The 601 serial digital signal is externally connected to analyzer DSP input for capture and analysis.
- PCI Interface** The PCI Interface circuitry connects the encoder module to the host processor. A programmable logic device contains the logic circuitry to address the chips on the decoder module. Addressing and data transfers to the devices on the module from the host processor is handled by the PCI interface. The PCI interface is configured from the Boot ROM.



## Composite Encoder

The composite generator is formed by a DSP and an optional composite video encoder module. The encoder block diagram is shown in Figure 3-10. As are the other modules, the encoder is a plug in circuit board that communicates with the server and the generator DSP through the PCI bus.

The NTSC/PAL Encoder module accepts 601 video at 270 MHz and converts it to NTSC (with or without setup) or PAL. The outputs are composite video and S-Video.

The following are requirements of the encoder module for the generator:

- The mode is set by filling the appropriate registers on the encoder board through the PCI bus interface.
- The module requires standard Rec, 601 input serial digital signals.
- The module is genlocked either through the passive analog loop-through input or by the recovered clock from the serial digital video input.

### Serial Receiver

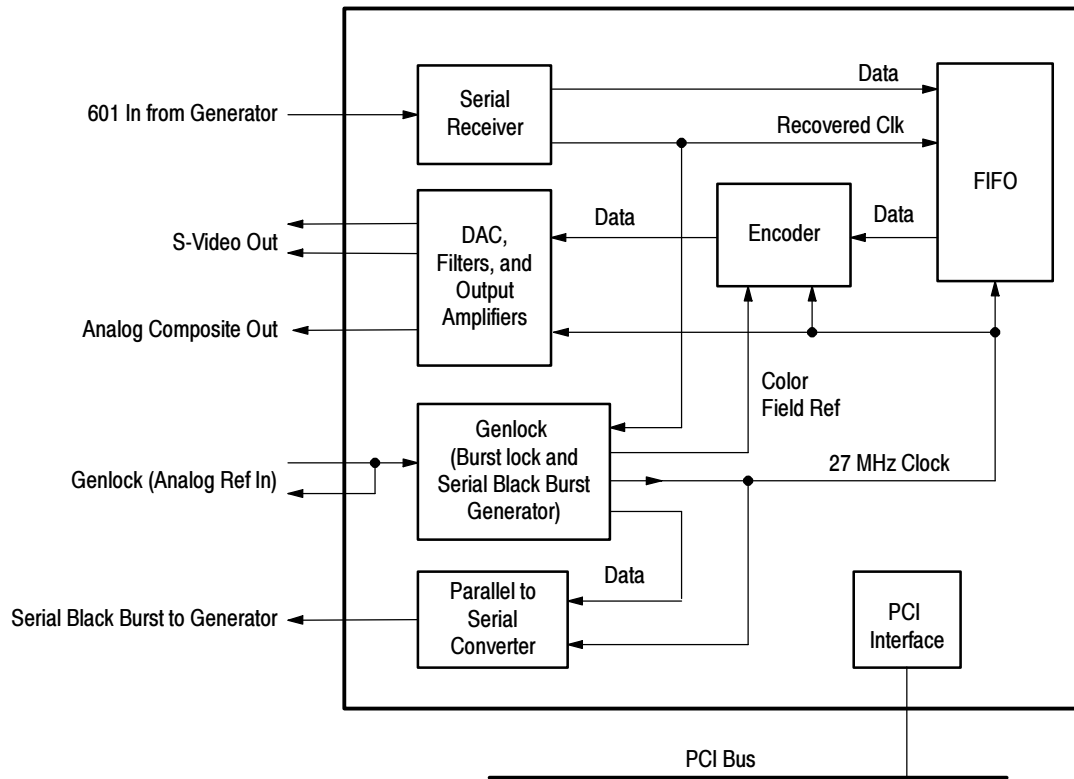
The serial digital input signal from the generator DSP is applied to a serial receiver for cable compensation. From the receiver the serial digital signal is applied to a serial-to-parallel converter. The recovered parallel 10-bit video data is clocked into a FIFO circuit. From the FIFO circuit, the data is clocked out with a 27 MHz clock that is locked either to the analog black burst input or the recovered clock from the serial digital signal input.

### Encoder

The parallel video is clocked out of the FIFO circuit to an encoder ASIC using the internal 27 MHz clock. The encoder develops the video as Y/C component output. The Y/C output is processed through the DAC, the low-pass filter, and the output amplifier. The Y and C outputs are applied to a summing circuit to obtain the composite video output signal.

### Genlock

The genlock circuitry on the encoder board is similar to the color lock circuitry on the decoder board, shown in Figure 3-9. A sync stripper circuit in the genlock circuitry develops a clamped video output along with composite sync. The Chroma portion of the clamped video is stripped and applied to a Chroma subcarrier lock ASIC that controls the phase of the 27 MHz VCO (voltage-controlled oscillator). The VCO output is then used throughout the encoder module as the clocking signal.



**Figure 3- 10: Encoder simplified block diagram**

The 27 MHz clock signal also drives a circuit that develops the Fsc (subcarrier frequency). The Fsc circuit is reset every color frame to correct for any slight frequency errors. The Fsc output completes the phase lock loop back to the Chroma subcarrier lock ASIC.

**Serial Black Burst**

A programmable gate array device is used to generate the timing, detect Color Field, and generate the 601 serial black burst. The serial black burst signal is applied to the generator DSP to provide a genlock signal to that module. The external analog black burst signal has less jitter than the recovered clock from the serial digital input signal. If the encoder is locked to the analog black burst input signal, the recovered clock from the serial digital video is at the same rate, but the two are not phase-locked. The FIFO circuit accommodates the phase difference.

**PCI Interface**

The PCI Interface circuitry connects the encoder module to the host processor.



# Performance Verification



# Performance Verification

This section contains procedures for verifying that the instrument performs according to the characteristics stated in the *Specifications* section.

If the instrument is not able to pass these tests, refer to the *Maintenance* section for troubleshooting procedures.

---

**NOTE.** To complete the procedures in this section you need a basic understanding of the Windows NT operating system, and the PQA300 Picture Quality Analysis System application. For detailed operating instructions, refer to the Windows NT manuals and the PQA300 Picture Quality Analysis System User Manual.

---

## Test Interval

Perform the procedure once every 2000 hours of operation or every 12 months to ensure that the performance is within tolerance.

## Prerequisites

The tests in this section comprise an extensive, valid confirmation of performance and functionality when the following performance conditions have been met:

- The instrument must be in an environment with temperature, altitude, humidity, and vibration within the operating limits described in the *Specifications* section.
- The instrument must have had a warm-up period of at least 20 minutes.

## Equipment Required

Table 4-1 lists the test equipment needed to complete the Performance Verification procedure. The table identifies examples and minimum tolerances, where applicable. If you substitute other equipment for the examples listed in Table 4-1, the equipment must meet or exceed the tolerances.

**Table 4- 1: Required equipment list**

<b>Test equipment</b>	<b>Minimum requirement</b>	<b>Example</b>
Serial digital video monitor	Receives and displays serial digital video signals in ITU-R BT.601 format.	Sony video monitor with serial digital interface, BVM-14F5U with Option BKM-21D
Test Oscilloscope	Bandwidth DC to 1 GHz	Tektronix TDS784 Oscilloscope
Matching Pad	75 $\Omega$ to 50 $\Omega$ matching pad	Tektronix AMT75
Frequency Counter with 1 M $\Omega$ probe	Frequency 100 MHz 10-digit resolution; accuracy 0.1 ppm (referenced to WWV, GPS, or with a high accuracy time base).	Hewlett-Packard Model 53131A
75 $\Omega$ coaxial cables (2)	Low-loss video cable, double shielded; BNC male to BNC male 72 in.	Tektronix part number 012-0159-01
75 $\Omega$ SMB to BNC adapter cables (2)	BNC male to SMB female, test equipment interconnection, 39.5 in.	Tektronix part number 174-3579-00
S-Video signal cable	Standard S-Video cable, 72 in., 4 pin DIN connectors on both ends.	Tektronix part number 012-1554-00
S-Video to dual BNC adapter cable	Standard S-Video connector to dual BNC male connector for Y and C outputs.	Pacific Radio Electronics S4P-Y-BNC-6
75 feed-through termination	Termination impedance 75 $\Omega$ ; connectors BNC male to BNC female.	Tektronix part number 011-0051-01
BNC dual female connector	BNC barrel connector; BNC female to BNC female	Tektronix part number 103-0028-00
BNC to dual binding post adapter	BNC male connector with dual banana jack binding post with center and ground indicated.	Tektronix part number 103-0035-00
Impaired Video Test Sequence CD	Video test sequence with known impairments	Tektronix part number 063-3025-00



---

**NOTE.** *The PQA300 uses automatic login with the user name of Administrator and the password of PQA300. No other user can log in while the autologin property of the application is enabled.*

*If it becomes necessary to disable the automatic login, you must run the Regedit (registration edit) program and set the HKEY\_LOCAL\_MACHINE\SOFTWARE\Microsoft\Windows NT\CurrentVersion\Winlogon\AutoAdminLog value to 0. It must be reset to 1 to enable automatic login. See Configure for Auto Boot Up in Appendix C.*

---

4. If autologin is disabled as described in the preceding note, use the key sequence CTRL + ALT + Delete to display the login dialog box. There are three possible logins:
  - You can log in as **Administrator** and use **PQA300** as the password. This user can load software, change passwords, assign users, and make the Windows NT system setups for the network.
  - You can log in as **PQA300** without entering any password. Use this login for normal use of the system for testing picture quality.
  - You can log in as **Guest** without entering any password. A guest has only limited access to files and applications.

### **Load the Impaired Test Sequences**

The following procedure loads the impaired video test sequences that are used for testing the system.

1. Place the impaired video test sequence CD-ROM in the CD drive. As soon as the CD is recognized, an Install Wizard is initiated to assist you in loading the test sequences. (Refer to *Installing the Generator and Reference Sequences* on page A-5 for the procedure for installing files from the CD-ROM disc.)
2. Load the three impaired video test sequences (Mobile+.601-525 or Mobile+.601-625 as needed for your system) from the Impaired Video Test Sequence CD-ROM to the hard disk drive.

---

**NOTE.** *To make the verification procedure shorter, load only the reference and generate video sequences of the format that you expect to use most (601-625 or 601-525). The following procedure uses the Mobile3mbs+ impaired video test sequence to run the first impaired video measurement. If you want to test all the impaired video sequences, load them all now.*

---



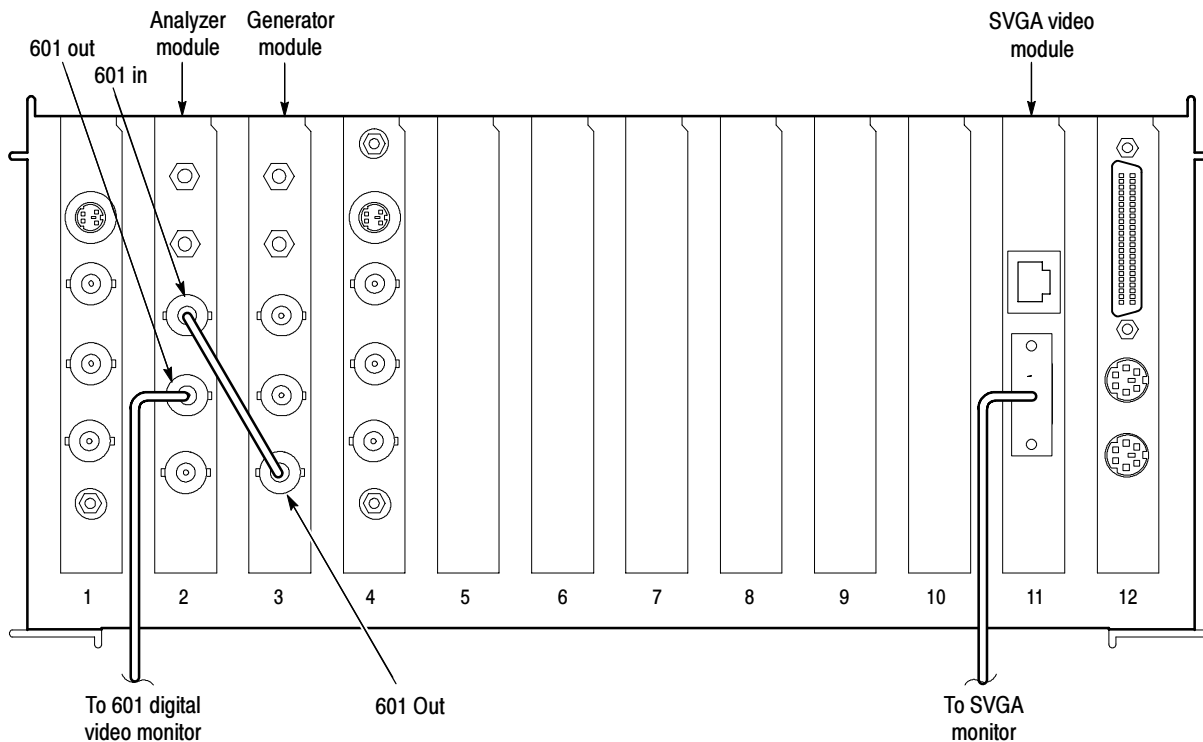
**Table 4-2: Impaired video test sequences disk**

Sequence format	Sequence title	Sample rate
601-525	Mobile3mbs+.601	3 Mbits/sec
601-525	Mobile6mbs+.601	6 Mbits/sec
601-525	Mobile9mbs+.601	9 Mbits/sec
601-625	Mobile3mbs+.601	3 Mbits/sec
601-625	Mobile6mbs+.601	6 Mbits/sec
601-625	Mobile9mbs+.601	9 Mbits/sec

### Set Up the PQA300 System for Serial Digital Testing

The following procedure sets up the PQA300 Picture Quality Analysis System to generate a test sequence, capture that same test sequence, measure the captured test sequence against the stored reference sequence, and display the measurement results.

1. Connect the Generator 601 Out (BNC connector) to the Analyzer Channel A In (BNC connector) using 75  $\Omega$  coaxial cable as shown in Figure 4-2.

**Figure 4-2: Initial connections for the functional check**

2. Use the BNC-to-BNC coaxial cable to connect the Channel A Loop Through Out BNC connector of the analyzer to the serial digital input of the external digital video monitor.
3. Set up the video monitor to view the serial digital input.
4. Right click the Preference soft key to display the Preference Configuration menu.
5. Click the down arrow in the Startup Presets name field.
  - a. Click on the factory preset to select it.
6. Click OK to accept the change and exit the menu.
7. Click the Preference soft key to restore the factory configuration settings.
8. Right click the Generate soft key to display the Generate Configuration menu.
9. Select the correct signal type (601-525 or 601-625).
10. Select to generate the Mobile+ sequence.
11. Click OK to accept the changes and exit the menu.
12. Right click the Capture soft key to display the Capture Configuration menu.
13. Select the correct signal type (601-525 or 601-625). This selection must be the same signal type as the sequence you selected to generate for the test.
14. Select Mobile+ as the reference to use or use the factory default, Any Valid Sequence.

---

**NOTE.** *The stored reference sequence names are available for selection. You may select Any valid sequence as a capture choice, but if the captured sequence does not have a matching reference sequence stored in the reference directory, you get an error message when you try to measure it. You can add the matching reference to the hard disk later and select the sequence to be measured. When you start the measurement again, the matching reference file is found and the measurements you have selected are done.*

---

15. Either give the test an alias name or leave the test name edit field blank. If left blank, a default file name is given to the captured sequence when it is saved.
16. Click the OK button to accept the changes and exit the menu.
17. Right click the Measure soft key to display the Measure Configuration menu.

18. The captured sequence is the default choice to measure.
19. Select PQR Luma, PQR Luma & Chroma, and PSNR Luma in the Picture Quality Measurement box.
20. Click the OK button to accept the changes and exit the menu.

### Unimpaired Sequence Test

1. Click the Generate soft key to start generating the Mobile+ test sequence.
2. Click the Capture soft key to start the capture operation.
3. Check that the test sequence is displayed on the external serial digital monitor to verify the Channel A Out active loop through.
4. Wait for the test sequence to be captured. The message “Captured sequence stored” with the name, format, and file extension is displayed when the capture is done. Note the time stamp of the sequence just stored for future reference. If you have several sequences of the same name, only the time stamp distinguishes one from another.
5. Click the Measure soft key to start the measurement.

You should see the PQR map of each field as it is being processed. The progress indicator and the messages in the status bar show you what is happening along with the field number that is being processed.

After the PQR analysis finishes, the PSNR measurement is started. The PSNR map of each field is also displayed as the measurements are made. When the measurements have completed, the Summary results are displayed.

6. Check the Summary results for the correct measurement values for the unimpaired video test sequence.

PQR Luma	0.00
PQR Luma & Chroma	0.00
PSNR Luma	Infinite

7. Click the soft key at the bottom right of the soft key menu selections (now labeled Summary). The label changes to Details, and Details table is displayed.
8. Check that the Details results PQR fields are all 0.00 and the PSNR fields are all INFINITE.
9. Click the soft key at the bottom right of the soft key menu selections (now labeled Details). The label changes to Graph, and the results graph is displayed.
10. Check the PSNR graph for a row of Xs at the bottom of the graph (X signifies infinite).

11. In the Legend box, select the PQR graph. Check the PQR graph results for a straight horizontal line graph at 0.
12. Select the PQR YC graph. Check the PQR graph results for a straight horizontal line graph at 0.

If PSNR and PQR values are correct, the generate, capture, measure, and results display functions of the DSP modules are verified for the unimpaired video sequences.

### **Impaired Sequence Test**

After you have confirmed that the unimpaired video test is correct, use the following procedure to test one or more of the impaired video sequence. Measuring the impaired test sequence against the stored reference sequence provides a check on the operation of the measurement algorithm with different levels of impairment in the video material.

1. In the Generate Configuration menu, select one of the impaired video test sequences (for example, Mobile3mbs+).
2. In the Capture Configuration menu, select the correct signal type (601-525 or 601-625).
3. Select the Mobile+ reference sequence. This reference matches the name in the header ID for all the Mobile+ impaired video test sequences.
4. Click the Generate soft key to start generating the impaired test sequence.
5. Click the Capture soft key to start the capture operation.
6. Wait for the test sequence to be captured. The message “Capture sequence saved” with the name, format, and file extension is displayed when the capture is done. Note the time stamp of the sequence just saved for future reference. If you have several sequences of the same name, only the time stamp distinguishes one from another.
7. Click on the Measure soft key to start the measurement. The progress indicator and the messages in the status bar show you what is happening. As with a capture, features that become unavailable during a measure are grayed out. When all the measurements have completed, the Summary results are displayed.
8. Check the Summary results for the correct measurement values for the captured impaired video test sequence against the values given either in Table 4-3 or in Table 4-4, as appropriate. The values given in the tables after the PQR and PSNR numbers are the detected parameter values. The parameter values, especially the levels, are typical and can vary as the algorithm is adjusted.

The PQR and PSNR values you measure should be very close to the values given in the tables. If the PQR and PSNR values are correct, the measure algorithms are verified.

9. If there is a significant difference between the measured PQR values or the PSNR values for an impaired sequence and the values given in the table for that sequence, recheck your configuration and redo the test. If the problem persists, refer it to a qualified service person.

**Table 4-3: Mobile+ 601-525 impaired video test sequence results and correction values**

Mobile at 3 MB/s		Mobile at 6 MB/s		Mobile at 9 MB/s	
PQR Luma	8.10	PQR Luma	5.40	PQR Luma	4.20
PQR Luma & Chroma	8.50	PQR Luma & Chroma	5.70	PQR Luma & Chroma	4.40
PSNR Luma	24.00	PSNR Luma	27.20	PSNR Luma	29.50
Y-XShift	0.006	Y-XShift	-0.006	Y-XShift	0.000
Cb-XShift	-0.006	Cb-XShift	0.001	Cb-XShift	0.002
Cr-XShift	0.003	Cr-XShift	-0.005	Cr-XShift	-0.002
Y-YShift	0.000	Y-YShift	0.000	Y-YShift	0.000
Cb-YShift	0.000	Cb-YShift	0.000	Cb-YShift	0.000
Cr-YShift	0.000	Cr-YShift	0.000	Cr-YShift	0.000
Left Crop	8	Left Crop	8	Left Crop	8
Top Crop	4	Top Crop	4	Top Crop	4
Right Crop	8	Right Crop	8	Right Crop	8
Bottom Crop	4	Bottom Crop	4	Bottom Crop	4
Y-Level	1.606	Y-Level	0.782	Y-Level	0.134
Cb-Level	0.089	Cb-Level	0.087	Cb-Level	0.058
Cr-Level	-0.463	Cr-Level	-0.045	Cr-Level	0.429
Y-Gain	0.978	Y-Gain	0.993	Y-Gain	0.999
Cb-Gain	0.986	Cb-Gain	0.992	Cb-Gain	0.992
Cr-Gain	0.992	Cr-Gain	1.000	Cr-Gain	0.995

**Table 4-4: Mobile+ 601-625 impaired video test sequence results**

Mobile at 3 MB/s		Mobile at 6 MB/s		Mobile at 9 MB/s	
PQR Luma	7.80	PQR Luma	5.30	PQR Luma	4.20
PQR Luma & Chroma	8.20	PQR Luma & Chroma	5.60	PQR Luma & Chroma	4.40
PSNR Luma	24.90	PSNR Luma	28.30	PSNR Luma	30.60
Y-XShift	0.001	Y-XShift	-0.005	Y-XShift	0.001
Cb-XShift	-0.004	Cb-XShift	0.001	Cb-XShift	0.001
Cr-XShift	-0.005	Cr-XShift	0.002	Cr-XShift	0.000
Y-YShift	0.000	Y-YShift	0.000	Y-YShift	0.000
Cb-YShift	0.000	Cb-YShift	0.000	Cb-YShift	0.000
Cr-YShift	0.000	Cr-YShift	0.000	Cr-YShift	0.000
Left Crop	8	Left Crop	8	Left Crop	8
Top Crop	0	Top Crop	0	Top Crop	0
Right Crop	8	Right Crop	8	Right Crop	8
Bottom Crop	0	Bottom Crop	0	Bottom Crop	0
Y-Level	0.085	Y-Level	-0.036	Y-Level	-0.116
Cb-Level	0.296	Cb-Level	0.119	Cb-Level	-0.011
Cr-Level	-0.455	Cr-Level	0.180	Cr-Level	0.111
Y-Gain	1.000	Y-Gain	0.999	Y-Gain	1.000
Cb-Gain	0.972	Cb-Gain	0.998	Cb-Gain	0.992
Cr-Gain	0.994	Cr-Gain	0.998	Cr-Gain	0.999

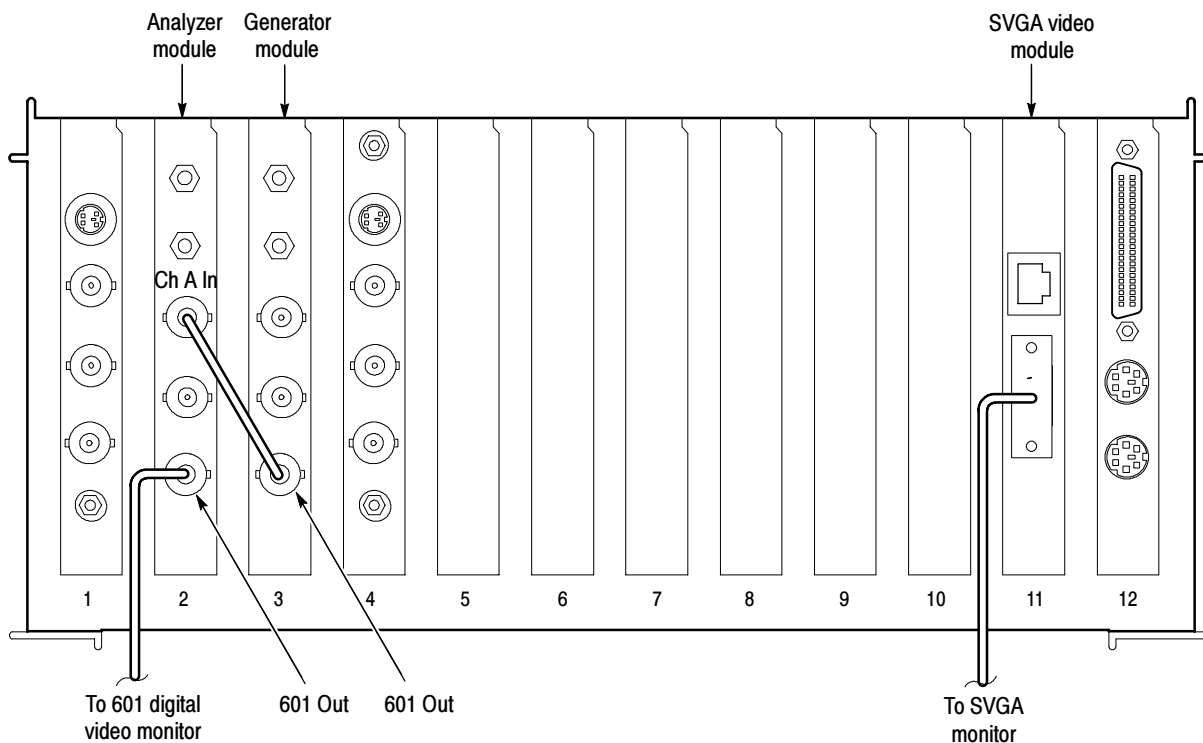
- 10.** If you want additional verification of the measure algorithm, you can repeat the impaired video sequence test using another of the impaired video test sequences. The expected test results for the impaired video sequences are given either in Table 4-3 or in Table 4-4, as appropriate for the video format.

### Check Analyzer DSP 601 Out Signal

The following procedure checks that the 601 Out connector provides a serial digital signal to the external serial digital monitor.

1. Disconnect the main loop-through out connection to the external digital monitor. You can also disconnect the generator 601 output from the analyzer Channel A In connector.
2. Connect the analyzer module 601 Out signal to the external monitor serial digital input connector as shown in Figure 4-3.

3. Right click the 601 Display soft key to display the External 601 Display Configuration menu.
4. Select Sequence as source of the video test sequence.
5. Select Mobile+ as the sequence to playback.
6. Check that Forward and Continuous are enabled.
7. Click OK to accept the changes and exit the menu.
8. Click on the 601 Display soft key to start the external video display of the Mobile+ signal.
9. After the sequence data is loaded from the hard drive, the analyzer starts outputting the sequence. Check that the video display on the external digital component video monitor is correct.
10. Disconnect the cable going to digital component video monitor from the analyzer Channel A Out BNC connector.



**Figure 4-3: Connection for analyzer 601 Out check**

## Analyzer 601 Out Amplitude

The 601 Out signal amplitude is measured using a test oscilloscope and a 75  $\Omega$  to 50  $\Omega$  matching pad. The test oscilloscope setup is very important in order to obtain a stable display of on pulse of the serial digital signal so that the positive and negative amplitude values of the waveform can be checked as accurately as possible.

The accuracy limits of the test equipment used precludes checking for the exact amplitude tolerance allowed for the Rec. 601 output (800 mV  $\pm$  80 mV). You can get a more accurate measurement if your test equipment is characterized to allow you to eliminate test equipment uncertainty from the measurement.

1. Connect the analyzer 601 Out connector through a 75  $\Omega$  coaxial cable and the 75  $\Omega$  to 50  $\Omega$  matching adapter to the CH1 input of the test oscilloscope.
2. Set the test oscilloscope for the settings given in Table 4-5. The parameters shown are for the example test oscilloscope given in the test equipment list. If you use an equivalent oscilloscope of a type other than the example, refer to the operating manual of that oscilloscope to determine the settings.

**Table 4-5: Test oscilloscope settings**

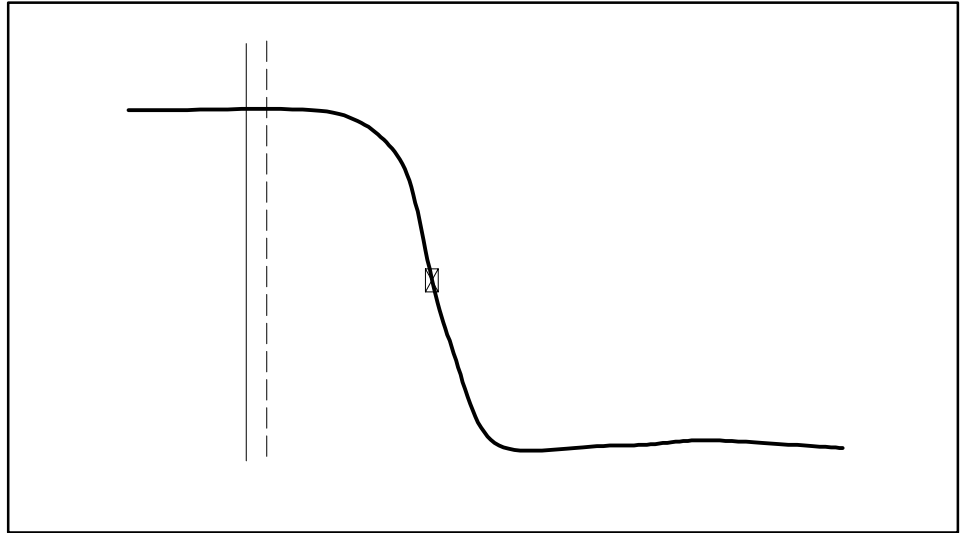
<b>CH 1 Vertical controls</b>	<b>Setting</b>
Coupling	DC
Bandwidth	Full
Vertical Scale	250 mV/div
Position	0 div
Offset	0 V
Deskew	0 s
Impedance	50 $\Omega$
CH 1	On
<b>Horizontal controls</b>	<b>Setting</b>
Time Base	Main at 2 ns
Trigger Position	50%
Record Length	500
<b>Acquisition controls</b>	<b>Setting</b>
Mode	Average at 24
Repetitive	Off
Stop After	RunStop Button
<b>Cursors</b>	<b>Setting</b>
Function	V Bars
Mode	Independent
Time Units	Seconds



**Table 4-5: Test oscilloscope settings (cont.)**

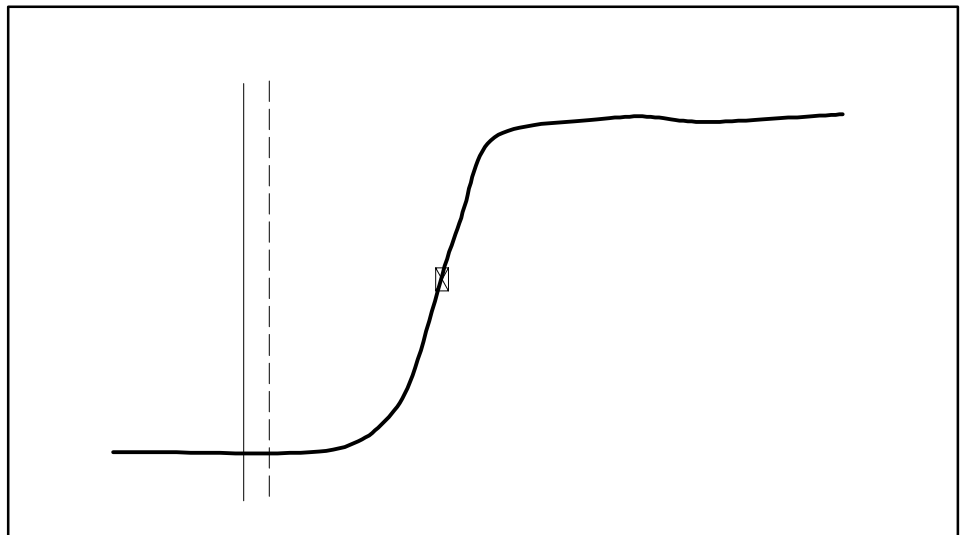
<b>Cursors</b>	<b>Setting</b>
Amplitude Units	Base
Position 1	-5.7 ns
Position 2	-5.6 ns
<b>Measurement</b>	<b>Setting</b>
Gating	On
Cursor Type	V-Bar Cursors
Measure 1 Type	High
Measure 2 Type	Low
Measure 3 Type	C1 Rise 20% to 80%
Measure 4 Type	C1 Fall 20% to 80%
Measure 1 Source	CH 1
Measure 2 Source	CH 1
Measure 3 State	ON
Measure 4 State	ON
Method	Minimum
<b>Trigger controls</b>	<b>Setting</b>
Type	Pulse
Class	Width
Source	CH1
Polarity	Positive
Trigger When	Within Limits
High Limit	35 ns
Low Limit	14 ns
Level	0 V
Mode	Normal
Holdoff	250 ns

3. The display that results when the setup is completed should look approximately as shown in Figure 4-4.
4. From the test oscilloscope, record the CH 1 High amplitude of the digital waveform. The value is approximately 400 mV.



**Figure 4-4: CH 1 high amplitude**

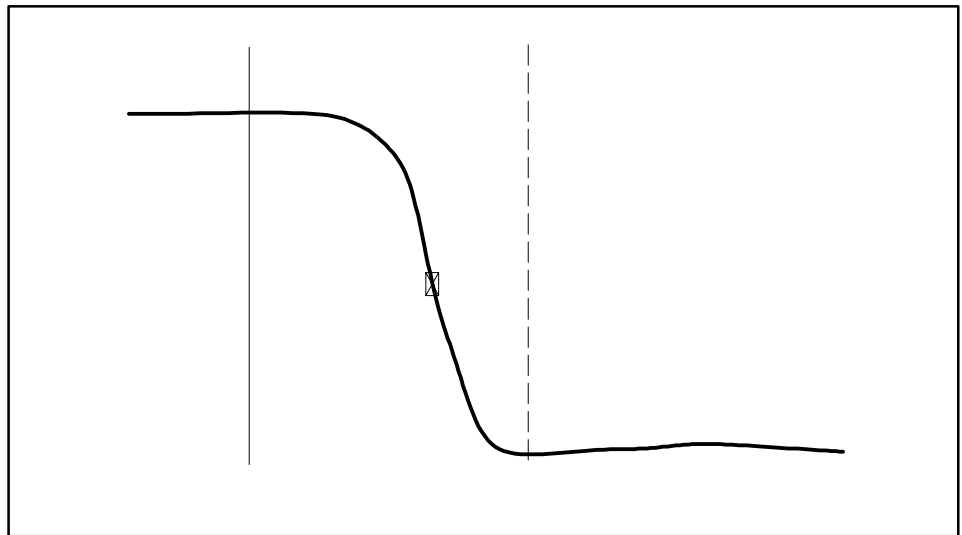
5. In the test oscilloscope Trigger menu, set the polarity to negative. After the measurement stabilizes, record the CH 1 Low amplitude of the digital signal waveform. The low value should also be approximately 400 mV.



**Figure 4-5: CH 1 low amplitude**

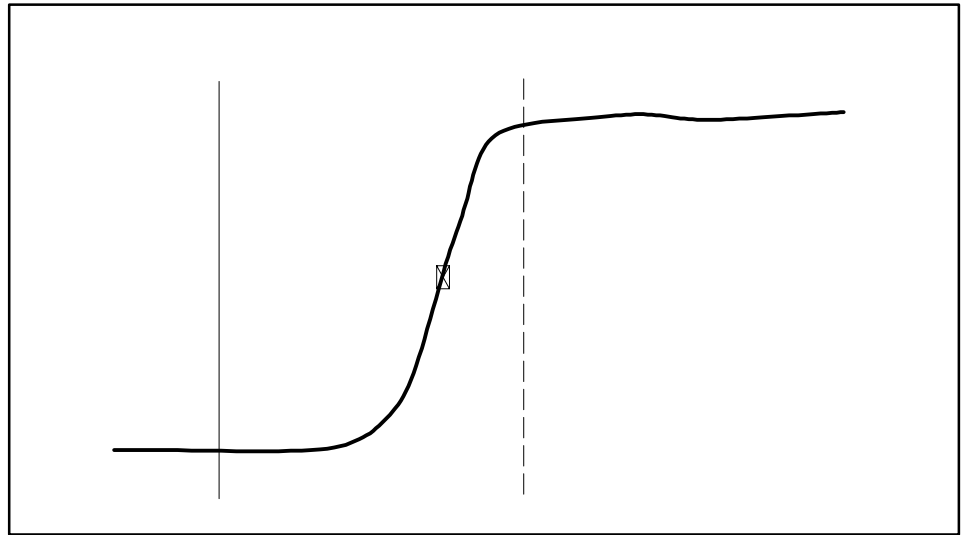
6. Add the absolute values of the high and the low amplitudes of the waveform.

7. Check that the sum of the high and low amplitude measurements is within the range of 738 mV to 862 mV. The measurement uncertainty due the accuracy of the example test equipment is taken into consideration in this range to verify that the output is within the allowable limits of  $800 \text{ mV} \pm 80 \text{ mV}$ .
8. Move the right most cursor to a position just after the falling edge as shown in Figure 4-6. The falling edge will be between the two cursors.



**Figure 4-6: CH 1 fall time**

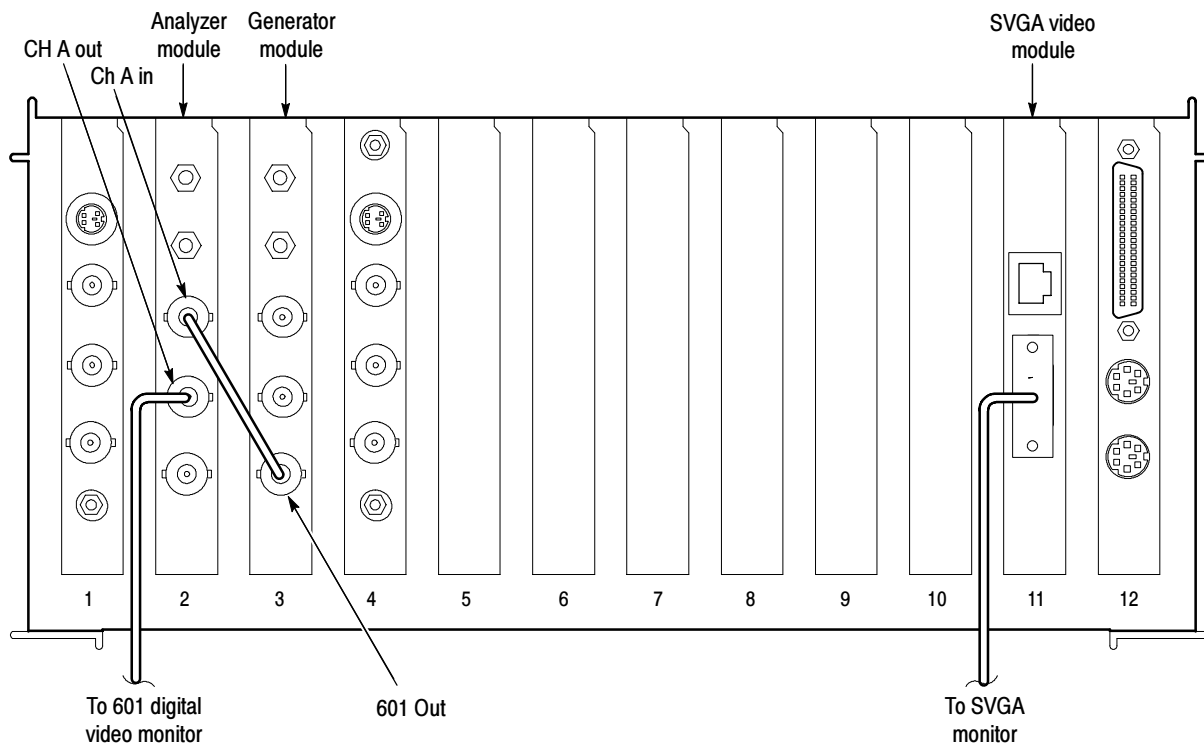
9. Verify that the Fall measurement is 1.2 ns or less.
10. Change the test oscilloscope trigger polarity to negative. The display will look approximately as shown in Figure 4-7.
11. Verify for that the Rise measurement is 1.2 ns or less.



**Figure 4-7: CH 1 rise time**

**Check Analyzer Channel  
A Out Loop Through  
Amplitude**

1. Using the 75  $\Omega$  coaxial cable, connect the analyzer Channel A Out connector through the 75  $\Omega$  to 50  $\Omega$  matching pad to the CH1 input of the test oscilloscope.
2. Connect the generator 601 Out connector to the analyzer Channel A In connector as shown in Figure 4-8.
3. If the test oscilloscope is not already set up as shown in Table 4-5, make those setups now; then go to step 4.
4. Click on the Generate soft key to start sending the video test sequence.
5. The display that results when the setup is completed should look approximately as shown in Figure 4-4.
6. From the test oscilloscope, record the CH 1 High amplitude of the digital waveform. The value is approximately 400 mV.



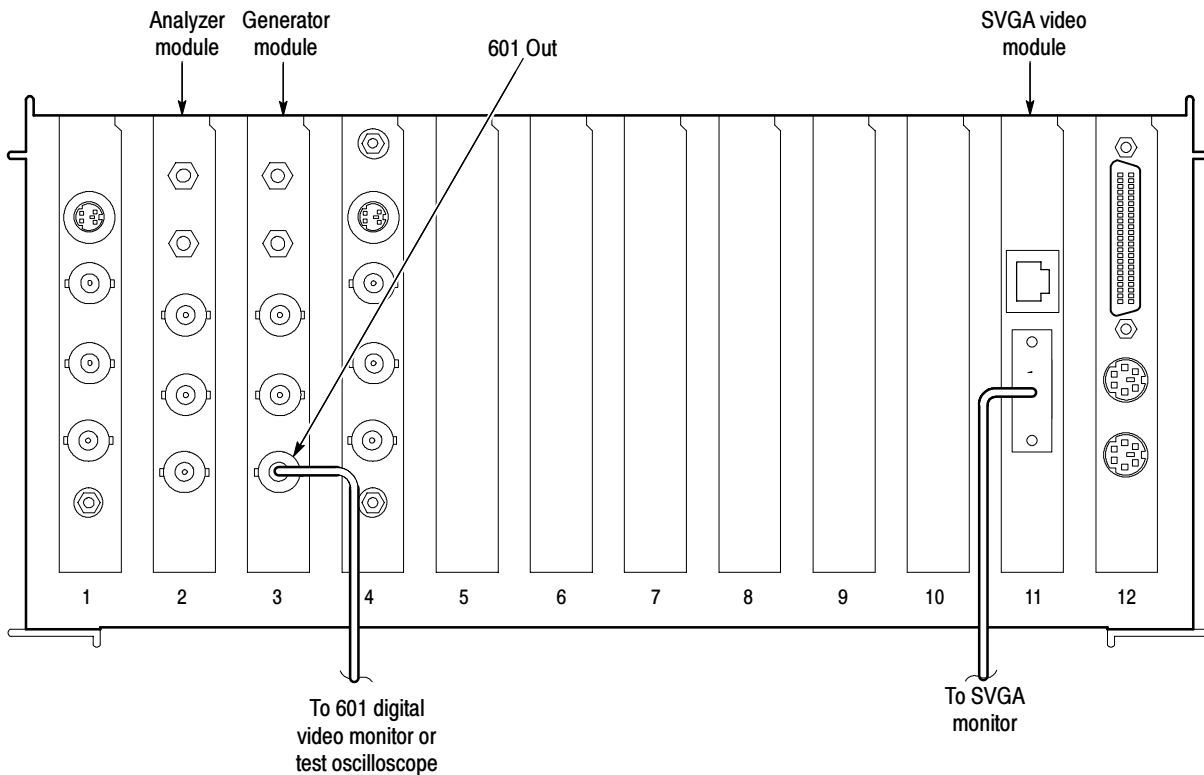
**Figure 4-8: Connection for analyzer Channel A Out loop through check**

7. In the test oscilloscope Trigger menu, set the polarity to negative. After the measurement stabilizes, record the CH 1 Low amplitude of the digital signal waveform. The low value should also be approximately 400 mV.
8. Add the absolute values of the high and the low amplitudes of the waveform.
9. Check that the sum of the high and low amplitude measurements is within the range of 738 mV to 862 mV.
10. Move the right most cursor to a position just after the falling edge as shown in Figure 4-6. The falling edge will be between the two cursors.
11. Verify that the Fall measurement is 1.2 ns or less.
12. Change the TDS784 Trigger Polarity to Negative. The display will look approximately as shown in Figure 4-7.
13. Verify for that the Rise measurement is 1.2 ns or less.

**Check Generator 601 Output**

Check the generator output for the correct serial digital format at 270 MB/s and for the correct output level.

1. Connect the generator module 601 Out connector to the serial digital input of the external video monitor as shown in Figure 4-9.
2. Check that the video display on the external video monitor is correct.
3. Click on the Generate soft key to stop generating the video test signal.
4. Verify that the external video monitor display is frozen.
5. Disconnect the video test signal cable from the external digital component video monitor.



**Figure 4-9: Connection for generator output check**

6. Using the 75  $\Omega$  coaxial cable, connect the Generator 601 Out connector through the 75  $\Omega$  to 50  $\Omega$  matching pad to the CH1 input of the test oscilloscope.
7. If the test oscilloscope is not already set up as shown in Table 4-5, make those setups and then go to step 8.

8. Click on the Generate soft key to start sending the video test sequence.
9. From the test oscilloscope, record the CH 1 Low amplitude of the digital waveform. The value is approximately 400 mV.
10. In the test oscilloscope Trigger menu, set the polarity to positive. After the measurement stabilizes, record the CH 1 High amplitude of the digital signal waveform.
11. Check that the sum of the high and low amplitude measurements is within the range of 738 mV to 858 mV.

### Check Generator Channel A Loop Through

1. Disconnect the Generator 601 Out signal from the matching pad.
2. Connect the Analyzer 601 Out connector to the Generator Channel A In connector using a 75  $\Omega$  coaxial cable. See Figure 4-10.
3. Connect the Generator Channel A Out loop through connector to the matching pad on the test oscilloscope CH 1 input.
4. Right click the 601 Display soft key to display the External 601 Playback Configuration menu.

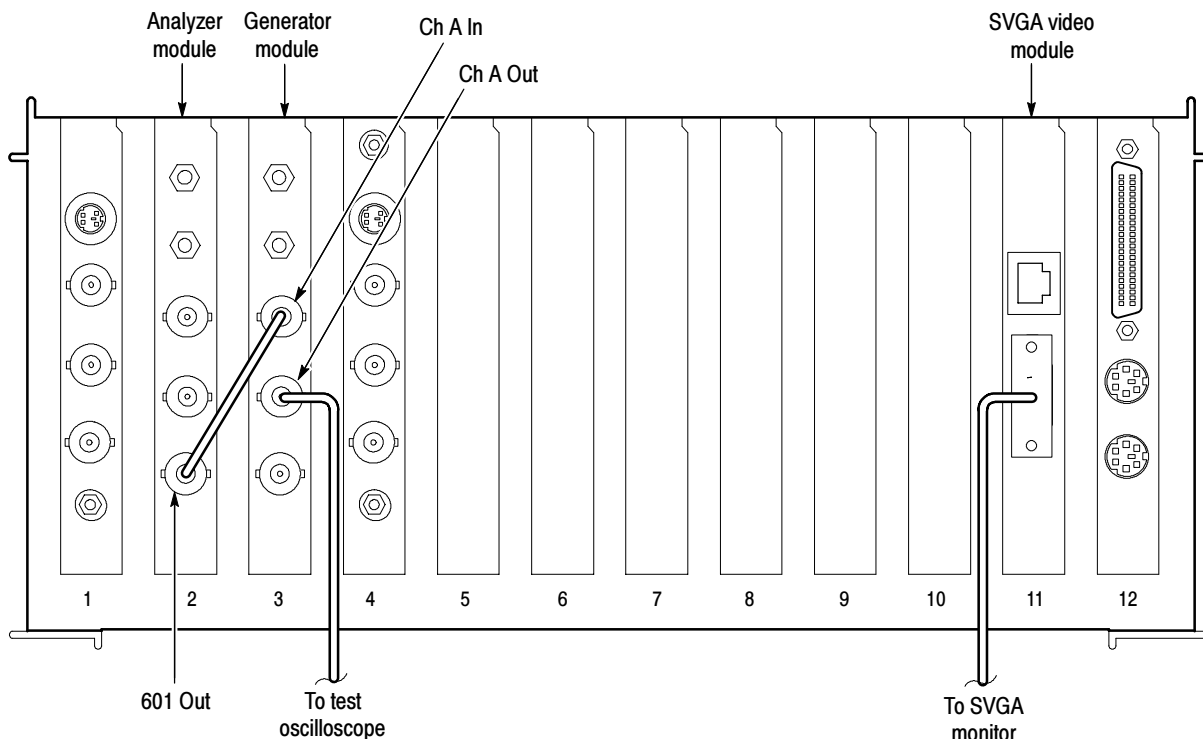


Figure 4-10: Connections for the Generator Channel A Out loop through check

5. Select the Mobile+ sequence in 601-525 or 601-625 as appropriate to play back to the 601 out connector.
6. Check that the playback is set for Continuous Looping.
7. Click on the OK button to accept the changes and exit the menu.
8. Click the 601 Display soft key to start the playback.
9. From the test oscilloscope, record the CH 1 Low amplitude of the digital waveform. The value is approximately 400 mV.
10. In the test oscilloscope Trigger menu, set the polarity to positive. Let the measurement stabilize. Record the CH 1 High amplitude of the digital waveform.
11. Check that the sum of the high and low amplitude measurements is within the range of 738 mV to 862 mV.
12. This ends the functional verification procedure for the analyzer and generator BNC connections. Disconnect the cables and test equipment.

### **Analyzer and Generator Channel B Out Loop Through Connectors**

The SMB Channel B In and Channel B Out connectors on the analyzer and generator are used for making connections to the Option 01 encoder and decoder modules. You can check the Channel B In and Channel B Out loop through connectors for both the analyzer and the generator in the same manner as done for the Channel A In and Channel A Out loop connectors. You need two BNC-to-SMB adapter cables to make the signal connections needed.

1. Use the generator 601 Out connector to supply an input signal to the analyzer Channel B In. Measure the peak-to-peak amplitude of the Channel B Out signal using the same procedure steps as in *Check the Analyzer Channel A Out Loop Through Amplitude* on page 4-16.
2. Use the analyzer 601 Out connector to supply an input signal to the generator Channel B In. Measure the peak-to-peak amplitude of the Channel B Out signal using the same procedure steps as in *Check the Generator Main Loop Through* on page 4-19.



## Option 1 Performance Verification

Performance verification of the Option 01 encoder and decoder modules consists of running the encoder and decoder user diagnostics, and then making PQR and PSNR picture quality measurements on unimpaired and impaired video test sequences.

The measurements are first made using a supplied test video sequence as the reference to verify the overall system. That same test video sequence is also captured as a new testing reference, and the measurements are redone using the new reference sequence. The second test eliminates the artifacts introduced by the encoder and decoder from the picture quality measurement and verifies capturing the correct color phase of the test video sequence. Finally, the test is done using an impaired test sequence as the test video sequence to capture.

In each of the tests, you check the measurement results against the expected values to verify the functionality of the encoder and decoder modules. The following procedure requires the PQA300 to be running and has passed the serial digital functional check.

### Run Encoder and Decoder Diagnostics

1. Click the Other soft key to display the selection menu and click on Hardware Settings and Diags to display the Hardware Settings menu seen in Figure 4-11.

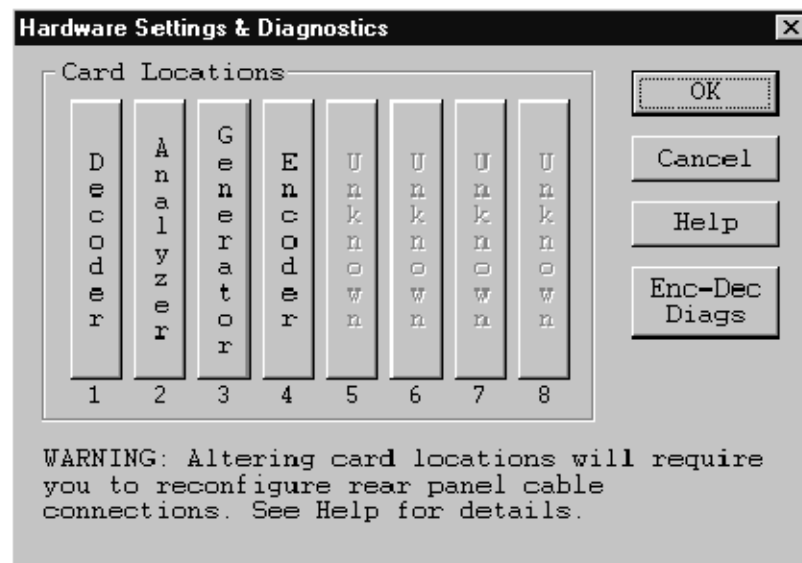
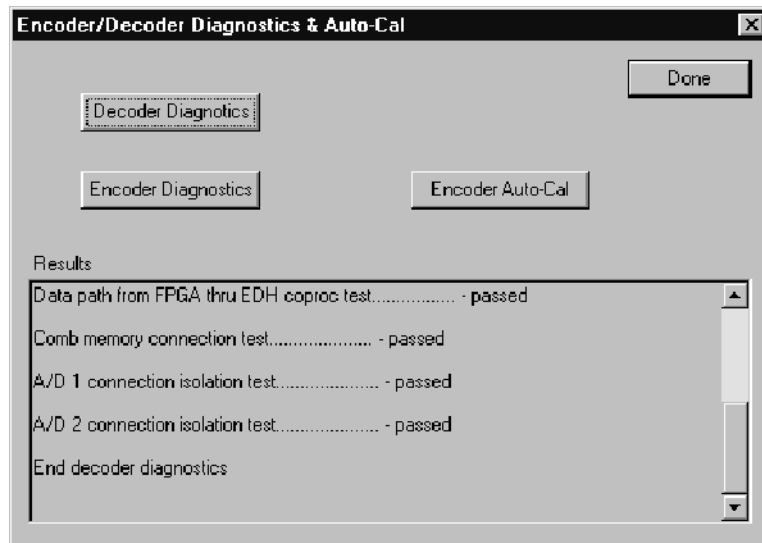


Figure 4-11: Hardware settings menu

2. A message stating that all the PQA300 applications must be stopped to continue appears. Continue with the hardware setup.
3. Click on the Enc-Dec Diags soft key to display the Encoder and Decoder Diagnostics menu shown in Figure 4-12. The diagnostic test for each module are separately selectable.
4. Click the Decoder diagnostics selection.

As the tests run, the test names are displayed in the Results box with the pass or fail result of the test. Use the scroll bar to view the completed test results.

5. If the decoder shows diagnostic failures, perform the decoder adjustment procedure (refer to *Decoder Board Adjustments* on page 5-7) and rerun the Decoder diagnostics again. If the decoder diagnostic failure persist, the decoder module may need to be replaced.
6. Click the Encoder diagnostics selection.



**Figure 4- 12: Encoder/Decoder diagnostics and Encoder Auto-Cal**

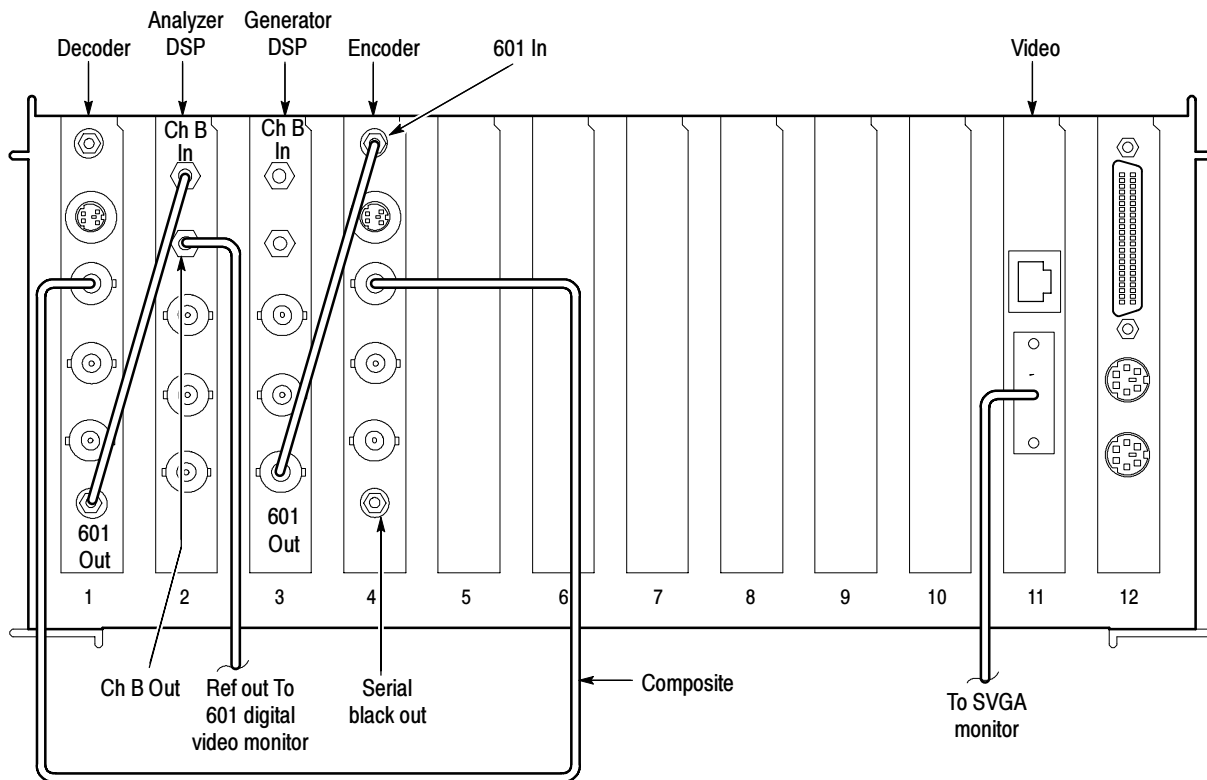
7. All the diagnostic tests should show a pass result. If the encoder does not pass any of the tests, perform the Encoder Auto-Cal and rerun the Encoder diagnostics.

**Encoder Auto-Cal.** Typically, you would use the Encoder Auto-Cal feature about every six months to maintain optimum encoder operation. The automatic calibration routine compensates the adjustments of the encoder module for temperature changes and aging. Run the Encoder Auto-Cal procedure using the following steps.

1. Allow the PQA300 to completely warm up (about 20 minutes) before the using the automatic calibration feature. This time permits all the circuitry to stabilize, and the auto-cal adjustments are then optimized for the normal operating temperature.
2. Click the Encoder Auto-Cal selection.
3. After the auto calibration has finished, rerun the Encoder Diagnostics to check for pass or fail of the diagnostic tests.
4. If the encoder still shows diagnostic failures after the auto calibration, refer your PQA300 system to a qualified service person for repairs.

### Set Up the PQA300 System for Composite Video Testing

The following procedure sets up the PQA300 Picture Quality Analysis System to generate an analog video test sequence, capture that same test sequence, measure the captured test sequence against the stored reference sequence, and display the measurement results. The cable connections required to interconnect the DSP modules with the encoder and decoder modules are shown in Figure 4-13. The encoder to generator DSP and decoder to analyzer DSP interconnection cable are standard accessories for Option 01.



**Figure 4-13: Connections for the encoder and decoder functional check**

1. Connect the Generator 601 Out BNC connector to the encoder 601 In SMB connector using the 75  $\Omega$  coaxial interconnection cable provided.
2. Do not connect the encoder Serial Black Out connector to the generator DSP Channel B In connector. If it is connected, disconnect it. Genlock (synchronizing the encoder to the generator) is derived from the serial digital video signal from the generator DSP.
3. Connect the decoder 601 Out SMB connector to the analyzer DSP Channel B In SMB connector using one of the 75  $\Omega$  coaxial interconnection cables provided.

4. Use the BNC-to-BNC coaxial cable to connect the encoder Composite Out BNC connector to the decoder Composite loop-through input.
5. Terminate the decoder Composite loop-through connector using a 75  $\Omega$  BNC termination.
6. Use a BNC-to-SMB adapter coaxial cable to connect the analyzer Channel B Out SMB connector to the 601 serial digital video monitor.
7. Set up the video monitor to view the serial digital input.
8. Double click on the PQA300 icon to start the application.
9. Right click the Preference soft key to display the Preference Configuration menu.
10. Click the down arrow in the Startup Presets name field.
11. Click on the factory preset to select it.
12. Click OK to accept the change and exit the menu.
13. Click the Preference softkey to restore the factory configuration settings.
14. Right click the Generate soft key.
15. Select the correct signal type for the test (NTSC, NTSC No Setup, or PAL). It is suggested that you do the first functional verification test using the format that you expect to use most or exclusively. You can elect to test for each of the signal types for a more thorough functional check.
16. Select to generate the Mobile+ sequence.
17. Click OK in the Generate Configuration menu to accept the changes and exit the menu.
18. Right click the Capture soft key to display the Capture Configuration menu.
19. Select the correct signal type for the test (NTSC, NTSC No Setup, or PAL).
20. Select Mobile+ as the reference sequence.
21. Set Capture As to Test.
22. Give the capture test an alias file name you can remember as you do the verification tests. For example, call the reference captured for NTSC “Mobile NTSC Test” and a reference captured for PAL “Mobile PAL Test”.
23. Click OK in the Capture Configuration menu to accept the changes and exit the menu.
24. Right click on the Measure soft key. When a new test is captured, it is the default choice to measure.

25. Select PQR Luma, PQR Luma & Chroma, and PSNR Luma in the Picture Quality Measurement box.
26. Click the OK button to accept the changes and exit the menu.

**Composite Sequence Test  
Using a 601 Ref**

1. Click the Generate soft key to start generating the Mobile+ test sequence.
2. Right click the Playback soft key to display the Playback Configuration menu.
3. Select Live as the choice to play back. Select the video format you have selected to capture in the Capture Configuration menu.
4. Click OK to accept the changes and exit the menu.
5. Click the Playback soft key to start the playback. The display is black until the generator starts the test sequence.
6. Click on the Capture soft key to start the capture operation.
7. Wait for the test sequence to be captured. The captured reference name, format, and file extension are displayed when the capture is done.
8. Click the Measure soft key to start the measurement. The captured test sequence is compared against the Mobile+ 601 reference, and the encoder and decoder effects are included in the measurements.

The PQR map of each field is displayed as it is being processed. The progress indicator and the messages in the status bar show you what is happening and the field number that is being processed.

After the PQR analysis finishes, the PSNR measurement starts. The PSNR map of each field is also displayed as the measurements are made. When the measurements have completed, the Summary results are displayed.

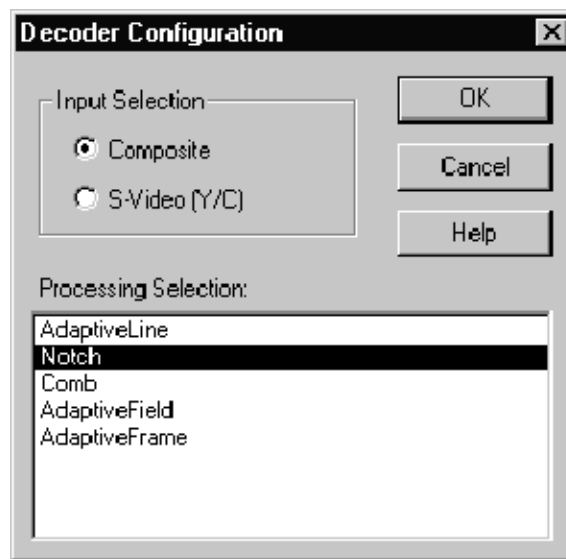
9. Check the Summary results against the typical values given for the unimpaired video test sequence in Table 4-6. The values you get for the PQR and PSNR numbers can be different, but should be about the same.

**Table 4-6: Summary PQR for unimpaired sequence using a 601 digital reference sequence**

Test	NTSC and NTSC no setup	PAL
PQR Luma	5.30	8.30
PQR Luma & Chroma	5.70	8.60
PSNR Luma	27.00	26.00

### Composite Sequence Test Using a De-embedded Ref

1. Right click on the Capture soft key to re-display the Capture Configuration menu.
2. Select to capture as a reference. Mobile+ should still be the Reference Sequence selected.
3. Give the reference capture an alias name that helps you remember the correct capture and reference to associate it with. For example, NTSC Notch Mobile Ref or PAL Notch Mobile Ref.
4. Click the Decoder soft key to display the menu shown in Figure 4-14.



**Figure 4-14: Decoder Configuration menu Notch processing selection**

5. Select Notch processing.
6. Click OK button to accept the changes and go to the Capture Configuration menu.
7. Click OK to accept the changes and exit the menu.
8. Click the Capture soft key to capture of the test video sequence as a reference.
9. Wait for the capture and store to finish.
10. When the status bar indicates that the captured sequence is stored, right click the Capture soft key to re-display the Capture Configuration menu.

11. In the Reference Sequence field, select the alias name of the reference sequence you captured in step 8 (NTSC Notch Mobile Ref or PAL Notch Mobile Ref).
12. Select to capture as a test.
13. Give the test capture an alias name that helps you remember the correct capture and reference to associate it with. For example, NTSC Notch Mobile Test or PAL Notch Mobile Test.
14. Click OK to accept the changes and exit the menu.
15. Click the Capture soft key to capture the Mobile+ sequence as a test.
16. After the test sequence has been captured and stored, click the Measure soft key to start the measurements. This time the picture quality analysis is done with respect to the captured reference. The effects of the encoder and decoder modules are eliminated (de-embedded) from the analysis.
17. Check the Summary results against the typical values for the unimpaired video test sequence given in Table 4-7. The values you get for the PQR and PSNR numbers can be different, but should be about the same.

**Table 4-7: Summary PQR for unimpaired sequence using a captured composite reference**

<b>Test</b>	<b>NTSC and NTSC no setup</b>	<b>PAL</b>
PQR Luma	0.90	1.40
PQR Luma & Chroma	0.90	1.40
PSNR Luma	48.00	45.00



**Composite Impaired  
Sequence Test**

After you have confirmed that the unimpaired composite video test is correct, use the following procedure to test one or more of the impaired video sequences. Measuring the impaired test sequence against the stored reference sequence provides a check on the operation of encoder and decoder modules with different levels of impairment in the video material.

1. In the Generate Configuration menu, select one of the impaired video test sequences (for example, Mobile3mbs+).
2. In the Capture Configuration menu, select the correct signal type for the test (NTSC, NTSC No Set Up, or PAL).
3. Select Mobile+ as the reference sequence.
4. Set Capture As to Test. Give the test capture a meaningful alias name so you can identify it in a list of captured files. That name is also displayed on the results displays to identify the results.
5. Click on the Decoder soft key.
6. Select Adaptive Line processing. Adaptive Line should be used in most cases when testing against the 601 digital reference.
7. Click OK to accept the changes and go to the Capture Configuration menu.
8. Click OK again to exit the Capture Configuration menu.
9. Click on the Generate soft key to start generating the test sequence.
10. Click on the Capture soft key to start the capture operation.
11. Wait for the test sequence to be captured. The message “Capture sequence saved” with the name, format, and file extension is displayed when the capture is done.
12. Click on the Measure soft key to start the measurement. The progress indicator and the messages in the status bar at the bottom of the PQA300 display shows you what is happening. When all the measurements have completed, the Summary results are displayed.
13. Check the Summary results for the correct measurement values for the captured impaired video test sequence compared to the typical values given either in Table 4-8 or in Table 4-9, as appropriate. Note that the NTSC and NTSC No Setup sequences are given as the same number. There are some minor differences between the two sequence types, but no more than the expected tolerance for either type.

The PQR and PSNR values you measure can be different than the typical values given in the tables, but they should be about the same. If the PQR and PSNR values are correct, the measure algorithms are verified.

14. If there is a significant difference between the PQR Luma value or the PSNR Luma values for an impaired sequence and the values given in the table for that sequence, check your setup again and redo the test. If the problem persists, refer the PQA300 system to a qualified service person.

**Table 4-8: Mobile+ NTSC and NTSC No Setup impaired video test sequence results for composite video**

Mobile at 3 MB/s		Mobile at 6 MB/s		Mobile at 9 MB/s	
PQR Luma	9.00	PQR Luma	7.00	PQR Luma	6.30
PQR Luma & Chroma	9.50	PQR Luma & Chroma	7.5	PQR Luma & Chroma	6.75
PSNR Luma	23.00	PSNR Luma	25.00	PSNR Luma	25.70

**Table 4-9: Mobile+ PAL impaired video test sequence results for composite video**

Mobile at 3 MB/s		Mobile at 6 MB/s		Mobile at 9 MB/s	
PQR Luma	10.20	PQR Luma	9.00	PQR Luma	8.60
PQR Luma & Chroma	10.80	PQR Luma & Chroma	9.50	PQR Luma & Chroma	9.00
PSNR Luma	23.30	PSNR Luma	24.50	PSNR Luma	25.00

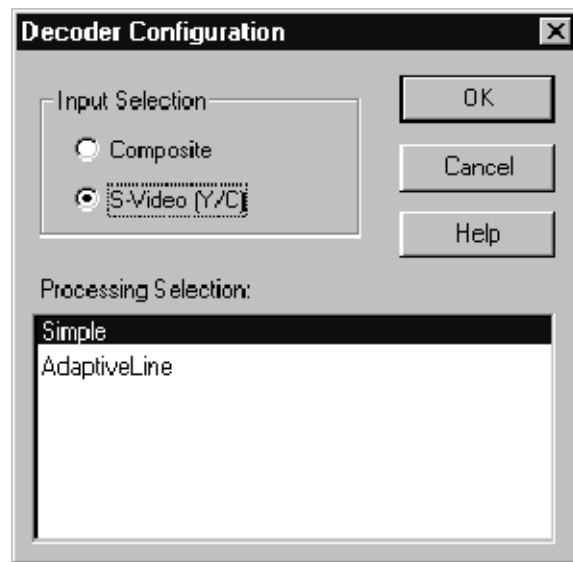
15. If you want additional verification of the measure algorithm, you can repeat the impaired video sequence test using another of the impaired video test sequences.

### S-Video Verification

You can check the S-Video functionality if you have an S-Video interconnection cable. The following procedure assumes that the composite video testing for Option 01 passed, and that the configuration settings are as made for those tests. Make the following changes to test the S-Video operation:

1. Connect the encoder S-Video out connector to the decoder S-Video input connector.
2. In the Capture Configuration menu, click on the Decoder button to display the Decoder Configuration menu shown in Figure 4-15.
3. Select S-Video as the input selection and Simple as the processing selection. (Simple is the only available selection for PAL video format.)
4. Click OK to accept the change and exit to the Capture Configuration menu.
5. Click OK in the Capture Configuration menu to exit the menu.

6. Rerun both composite unimpaired sequence tests (601-ref and de-embedded) starting on page 4-26 and the composite impaired sequence test starting on page 4-29. You have to recapture a new reference to eliminate (de-embed) the effects of the encoder and decoder. The measurement values for the unimpaired S-Video tested against the 601 serial digital reference are shown in Table 4-10. The measurement values for the unimpaired S-Video tested against a captured S-Video reference that de-embeds the encoder and decoder effects are shown in Table 4-11.



**Figure 4-15: Decoder Configuration menu for S-Video**

**Table 4-10: Summary picture quality values for unimpaired sequence against 601 serial digital reference**

Test	NTSC and NTSC no setup	PAL
PQR Luma	2.10	2.20
PQR Luma & Chroma	2.30	2.40
PSNR Luma	47.60	43.50

The testing results for S-Video shown in Table 4-10 are better than the same tests made on the composite video reference. S-Video has its luminance and chrominance already separated, and the encoder and decoder processing is less of a factor on the measurement values obtained. Notice that the results shown in Table 4-11, obtained using the de-embedding technique, are similar to the results of the composite video tests shown in Table 4-7.

**Table 4-11: Summary picture quality values for unimpaired sequence against captured S-Video reference using Simple processing**

Test	NTSC and NTSC no setup	PAL
PQR Luma	0.90	0.95
PQR Luma & Chroma	0.90	0.95
PSNR Luma	49.20	49.15

7. Verify the measured results for the unimpaired video sequence and the impaired video sequence against the typical expected results shown in Table 4-12 or Table 4-13, as appropriate for the video format of the test.

**Table 4-12: Mobile+ NTSC and NTSC No Setup impaired video test sequence results for S-Video**

Mobile at 3 MB/s		Mobile at 6 MB/s		Mobile at 9 MB/s	
PQR Luma	8.10	PQR Luma	5.50	PQR Luma	4.40
PQR Luma & Chroma	8.60	PQR Luma & Chroma	5.80	PQR Luma & Chroma	4.70
PSNR Luma	24.00	PSNR Luma	27.20	PSNR Luma	29.40

**Table 4-13: Mobile + PAL impaired video test sequence results for S-Video**

Mobile at 3 MB/s		Mobile at 6 MB/s		Mobile at 9 MB/s	
PQR Luma	8.00	PQR Luma	5.60	PQR Luma	4.50
PQR Luma & Chroma	8.35	PQR Luma & Chroma	5.90	PQR Luma & Chroma	4.90
PSNR Luma	24.90	PSNR Luma	28.30	PSNR Luma	30.50

### Format Verification

The functionality is verified using only one format, preferably the one you use for the majority of your testing. If you choose, you can redo all the tests in each of the video formats to verify the operation. In each step of the tests, select a different format than you used for the original testing. For example, if you used PAL format for the first test, select NTSC or NTSC No Setup. The expected measurement results for the impaired sequence testing are provided for each level of impairment of the provided impaired test sequences.

### Decoder 601 Out Amplitude

The 601 Out signal amplitude is measured using a test oscilloscope and a 75  $\Omega$  to 50  $\Omega$  matching pad. The test oscilloscope setup is identical to that used to test the DSP module 601 output amplitude.

1. Connect the decoder 601 Out connector through a 75  $\Omega$  coaxial cable and the 75  $\Omega$  to 50  $\Omega$  matching adapter to the CH1 input of the test oscilloscope. See Figure 4-16 for the PQA300 rear panel connections.
2. Use the BNC-to-BNC coaxial cable to connect the encoder Composite Out BNC connector to the decoder Composite loop-through input.
3. Terminate the decoder Composite loop-through connector using a 75  $\Omega$  BNC termination.
4. Set the test oscilloscope for the settings given in Table 4-5. The parameters shown are for the example test oscilloscope given in the test equipment list. If you use an equivalent oscilloscope of a type other than the example, refer to the operating manual of that oscilloscope to determine the settings.
5. Double click on the PQA300 icon to start the application.
6. Right click the Generate soft key.

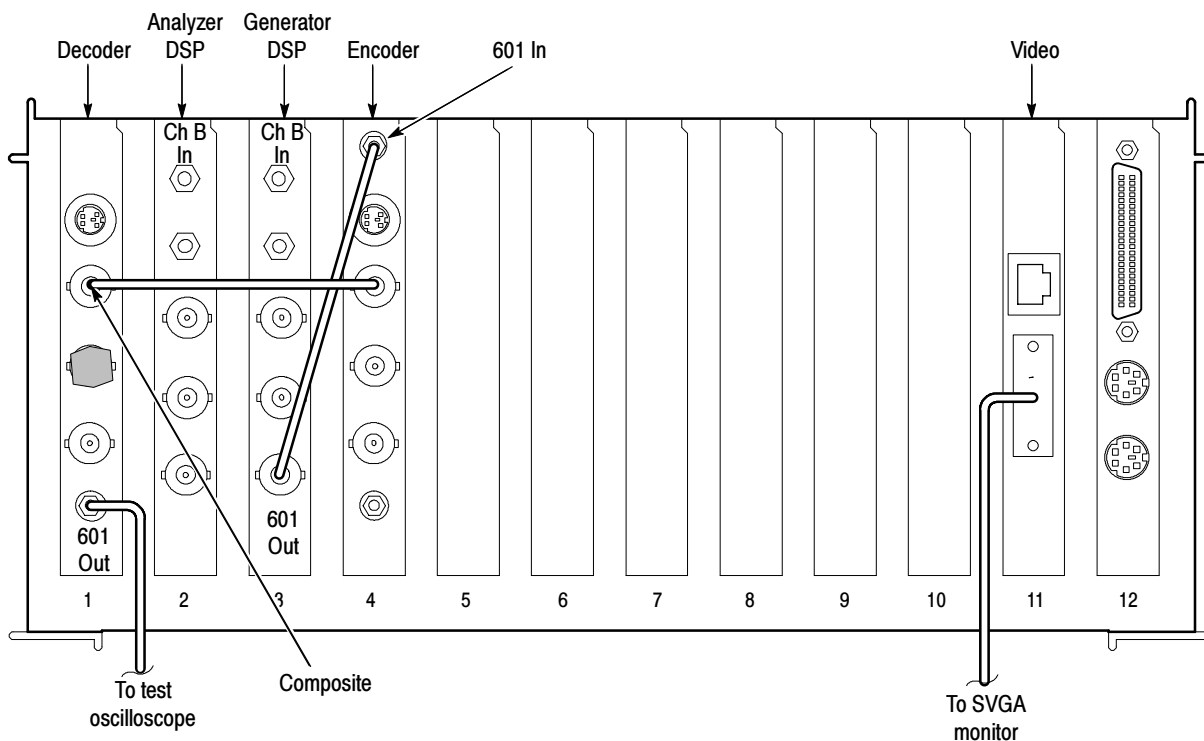
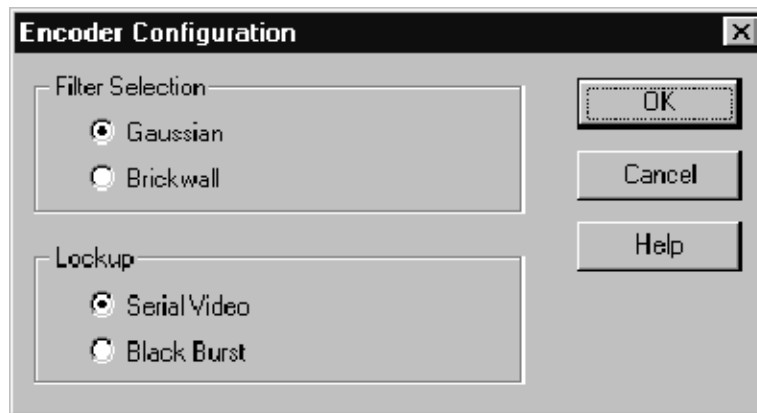


Figure 4-16: Connections for the decoder 601 output check

7. Select PAL format for the test.
8. Select to generate the Mobile+ sequence.
9. Select Continuous Looping.
10. Click the Encoder soft key to display the Encoder Configuration menu shown in Figure 4-17.
  - a. Select Gaussian filter.
  - b. Select the Serial Video Lockup (genlock) choice.
  - c. Click the OK button to accept the choices and exit back to the Generate Configuration menu.



**Figure 4- 17: Encoder Configuration menu**

11. Click OK in the Generate Configuration menu to accept the changes and exit the menu.
12. Right click the Capture soft key to display the Capture Configuration menu.
13. Select PAL format for the test.
14. Select Mobile+ as the reference sequence.
15. Click the Decoder soft key to display the Decoder Configuration menu.
16. Select Notch processing.
17. Click the OK button to accept the changes and exit to the Capture Configuration menu.
18. Click OK in the Capture Configuration menu to accept the changes and exit the menu.

19. Click the Generate soft key to start generating the test signal.
20. The display that results when the setup is completed should look approximately as shown in Figure 4-4.
21. From the test oscilloscope, record the CH 1 High amplitude of the digital waveform. The value is approximately 400 mV.
22. In the test oscilloscope Trigger menu, set the polarity to negative. After the measurement stabilizes, record the CH 1 Low amplitude of the digital signal waveform. The low value should also be approximately 400 mV.
23. Add the absolute values of the high and the low amplitudes of the waveform.
24. Check that the sum of the high and low amplitude measurements is within the range of 738 mV to 862 mV. The measurement uncertainty due the accuracy of the example test equipment is taken into consideration in this range to verify that the output is within the allowable limits of  $800 \text{ mV} \pm 80 \text{ mV}$ .
25. If the 601 output peak-to-peak amplitude is not with the expected limits, perform the Decoder Adjustment procedure. Refer to *Decoder Board Adjustments* on page 5-7.

### Check Encoder Output Amplitude Accuracy

This check verifies the operation of the Encoder Auto-Cal routine by first running the auto calibration feature, then checking that the Luminance and Chrominance gain and DC offset values are within the specified ranges. Both the composite video and S-Video output are checked.

**Run the Encoder Auto-Cal Routine.** Allow the PQA300 to completely warm up (about 20 minutes) before the using the automatic calibration feature. This time permits all the circuitry to stabilize and the auto-cal adjustments are then optimized for the normal operating temperature.

1. Click the Other soft key to display the selection menu and click on Hardware Settings and Diags to display the Hardware Settings menu seen in Figure 4-18. You will get a message telling you that all PQA300 applications must be stopped to continue. Click OK to continue.
2. Click on the Enc-Dec Diags soft key to display the Encoder and Decoder Diagnostics menu shown in Figure 4-19.
3. Click the Encoder Auto-Cal selection.
4. After the auto calibration has finished, run the Encoder Diagnostics to check for pass or fail of the diagnostic tests.
5. If the the encoder shows diagnostic failures after the auto calibration, refer your PQA300 system to a qualified service person for repairs.

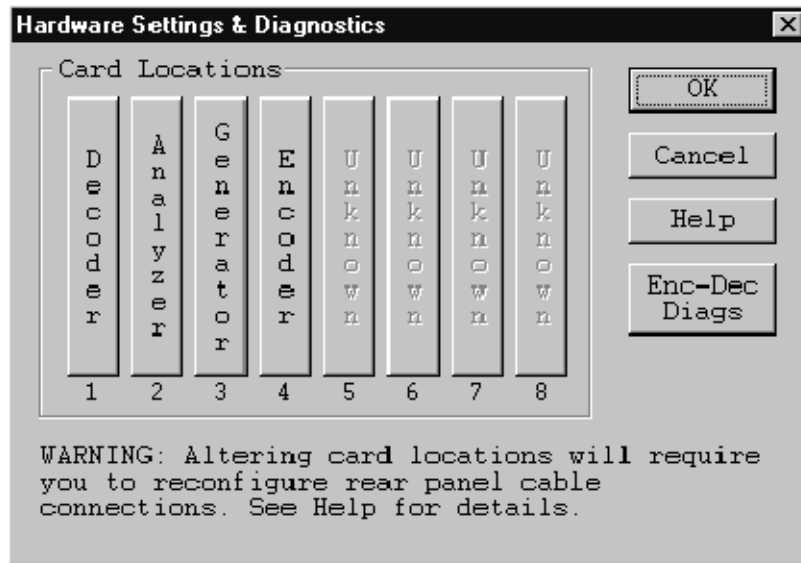


Figure 4- 18: Hardware settings menu

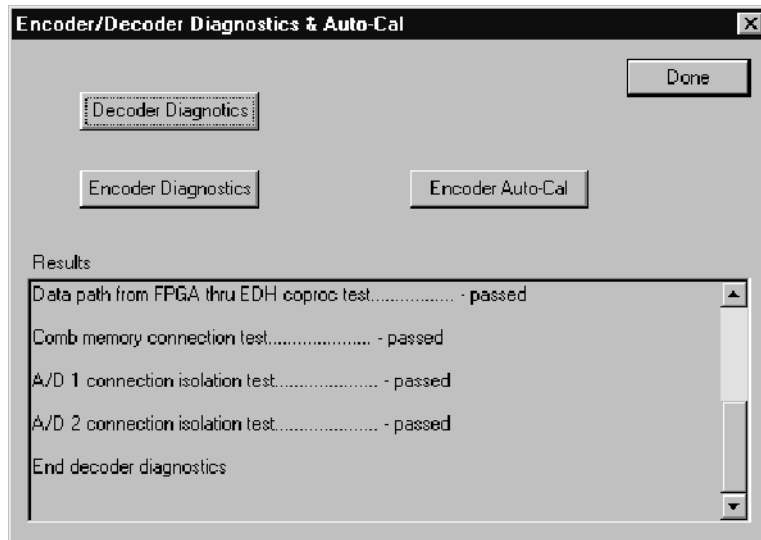
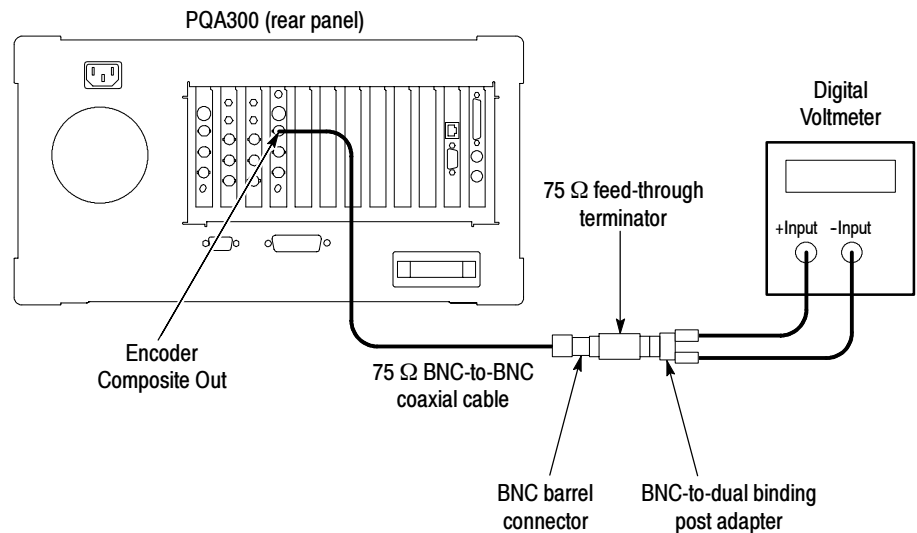


Figure 4- 19: Encoder/Decoder diagnostics and Encoder Auto-Cal



**Setup for Auto-Cal Verification.** Connect the test equipment and adapter cables as shown in Figure 4-20.



**Figure 4-20: Setup for Composite video luma (Y) and chroma (C) gain and offset**

1. Connect a 75 Ω cable to the Composite Output BNC connector on the encoder module.
2. Connect a 75 Ω feed-through termination to the coaxial cable BNC connector. Use a BNC female barrel connector to connect the termination to the adapter cable.
3. Connect a BNC to banana jack dual binding post adapter on the 75 Ω feed-through termination.
4. Connect the digital voltmeter + lead to the banana jack center conductor (RED) binding post and connect the - lead to the ground (BLACK) binding post.
5. Set the digital voltmeter to measure DC voltage on the 2 V range.

**Diagnostic Routine.** Run the supplied diagnostic routine to provide the reference DC voltage level inputs to the encoder.

1. Use the Windows NT directory tools to locate the diagnostic executable file. It is found in the PQA300/bin/support directory. The diagnostic file name is mmcodecs.exe.
2. Double click on the file name to start the diagnostic routine. A small PQA Encoder/Decoder dialog box is displayed.

---

**NOTE.** *This version of the PQA Encoder/Decoder diagnostics does not have a help file provided.*

---

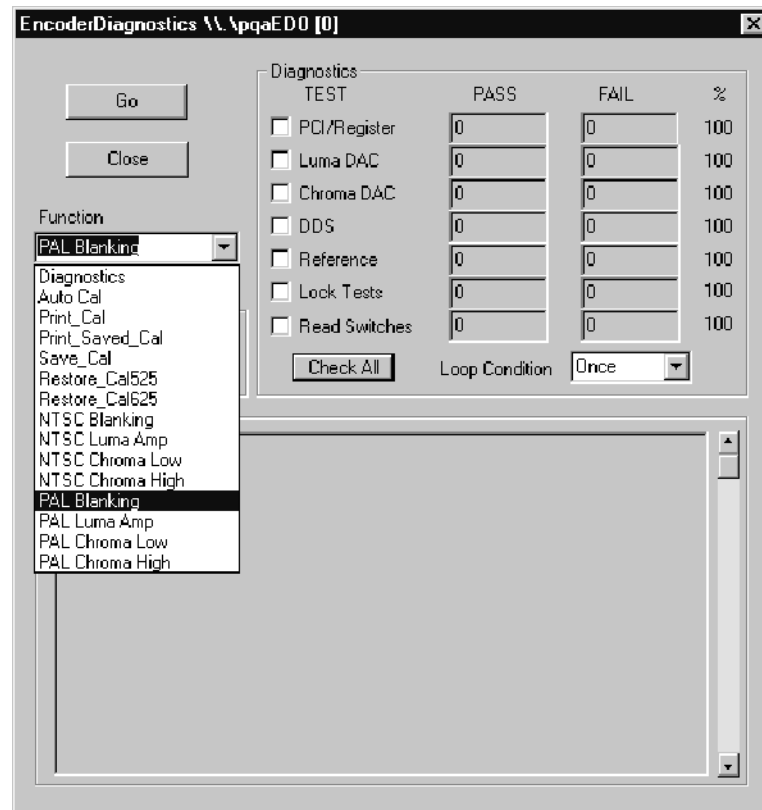


**Figure 4-21: PQA encoder/decoder dialog box**

3. In the dialog box, hold the mouse button down on Option to display the choices and select the encoder diagnostics. The Encoder diagnostic window appears.

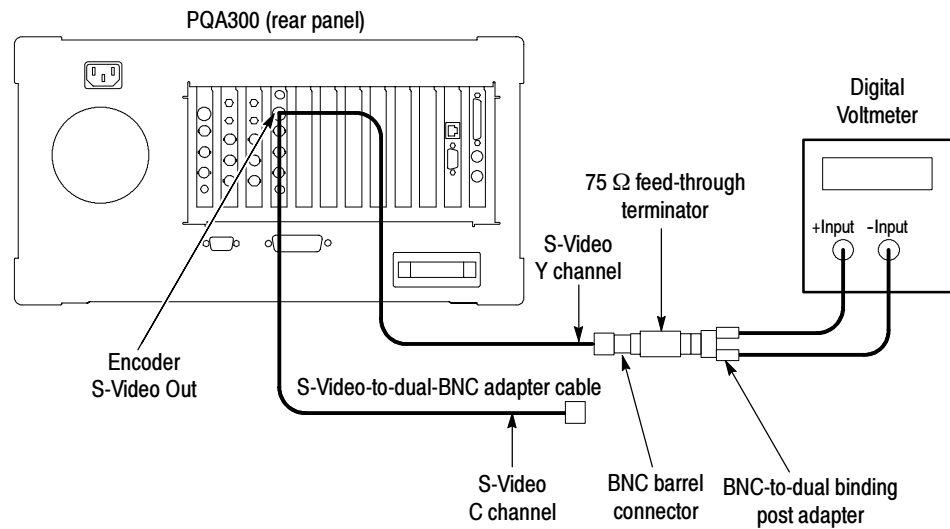
**PAL Luminance Gain and DC Offset.**

1. In the encoder diagnostics window, select PAL Blanking and press GO (see Figure 4-22).
2. Record the composite blanking DC level indicated on the voltmeter. The expected range is  $0 \pm 50$  mV.
3. Connect the S-Video to BNC adapter cable to the S-Video connector of the encoder module.
4. Move the  $75 \Omega$  feed-through termination from the composite video coaxial cable to the Y channel BNC connector of the S-Video to BNC adapter cable. Use a BNC female barrel connector to connect the termination to the adapter cable. See Figure 4-23 for the setup connections.



**Figure 4-22: Encoder diagnostics selection menu**

5. Record the S-Video Y channel blanking DC level indicated on the digital voltmeter. The expected range is  $0\text{ V} \pm 25\text{ mV}$ .
6. Move the  $75\ \Omega$  feed-through termination from the S-Video Y channel connector to the S-Video C channel connector.
7. Record the S-Video C channel blanking DC level indicated on the digital voltmeter. The expected range is  $0\text{ V} \pm 25\text{ mV}$ .
8. Move the  $75\ \Omega$  feed-through termination from the S-Video C channel connector back to the S-Video Y channel connector.
9. In the encoder diagnostics window select PAL Luma AMP and press GO.
10. Record the S-Video Y channel luminance level indicated on the digital voltmeter.
11. Move the  $75\ \Omega$  feed-through termination from the S-Video Y channel connector back to the Composite Output cable connector.



**Figure 4-23: Setup for S-Video luma (Y) and chroma (C) gain and offset**

12. Record the composite luminance amplitude indicated on the digital voltmeter.
13. Compute the net result (the difference between composite blanking and composite luminance levels) for Composite video. Check that the result is  $700 \text{ mV} \pm 7 \text{ mV}$ .
14. Compute the net result (the difference between S-Video blanking and S-Video luminance levels) for the S-Video signal. Check that the result is  $700 \text{ mV} \pm 14 \text{ mV}$ .

#### **PAL Chrominance Gain and DC Offset.**

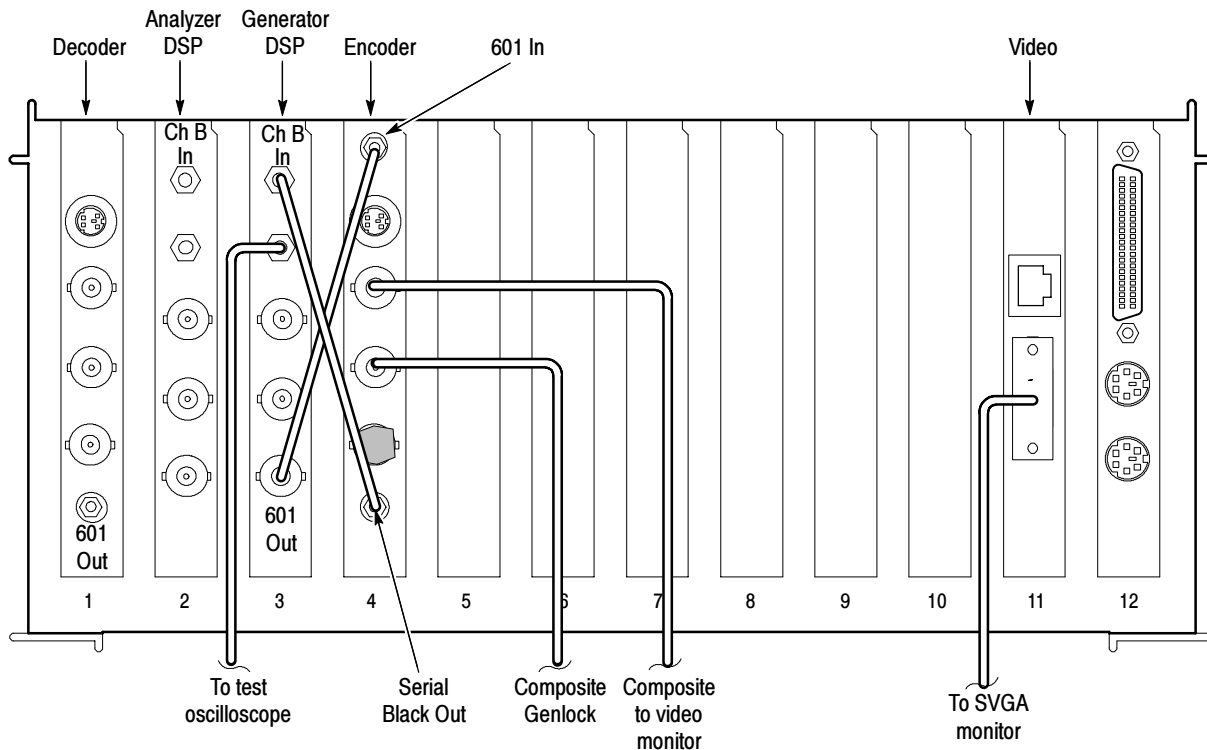
1. In the encoder diagnostics window, select PAL Chroma Low and press GO.
2. Record the composite output minus chroma level indicated on the digital voltmeter. The expected value is near  $-350 \text{ mV}$ .
3. Move the  $75 \Omega$  feed-through termination from the Composite Output coaxial cable connector to the S-Video C channel cable connector.
4. Record the S-Video C channel minus chroma level indicated on the digital voltmeter. The expected value is near  $-350 \text{ mV}$ .
5. In the encoder diagnostics window, select PAL Chroma High and press GO.
6. Record the S-Video C channel plus chroma level indicated on the digital voltmeter. The expected value is near  $+350 \text{ mV}$ .

7. Move the 75  $\Omega$  feed-through termination from the S-Video C channel connector back to the Composite Output cable connector.
8. Record the composite output plus chroma level indicated on the digital voltmeter. The expected value is near +350 mV.
9. Compute the composite video net results (add composite chroma plus and minus amplitude for the peak-to-peak value). Check that the result is 700 mV  $\pm$  7 mV.
10. Compute the S-Video net results (add S-Video chroma plus and minus amplitude for the peak-to-peak value). Check that the result is 700 mV  $\pm$  14 mV.

**Check Encoder Serial  
Black Out Genlock**

This procedure checks the encoder module genlock function and the Serial Black Output amplitude.

1. Connect a composite reference video source of the format you are testing (with burst) to the encoder Genlock feed through. Terminate the feed through using a 75  $\Omega$  BNC termination.
2. Connect test oscilloscope to the generator DSP Channel B Out SMB connector.
3. Using the SMB to BNC 75  $\Omega$  coaxial adapter cable, connect the generator Channel B Out connector through the 75  $\Omega$  to 50  $\Omega$  matching pad to the CH1 input of the test oscilloscope.
4. Connect the encoder Composite output to a composite video monitor setup to display the video format (NTSC, NTSC No Setup, or PAL) you want to use for the test.
5. Right click the Generate soft key to display the Generate Configuration menu.



**Figure 4-24: Connections for Serial Black Out and Genlock check**

6. In the Generate Configuration menu, select to generate a video sequence of the correct format for your test (NTSC, NTSC No Setup, or PAL) continuously.
7. Click on the Encoder soft key to display the Encoder Configuration menu.
8. In the Encoder Configuration menu, select Gaussian filtering and Serial Black lockup for the Genlock.
9. Click OK to accept the changes and exit to the Generator Configuration menu.
10. Click OK again to accept all the changes and exit the Generator Configuration menu.
11. Click the Generator soft key to start outputting the test sequence.
12. Check that the composite video sequence is displayed correctly on the video monitor.
13. Set up the test oscilloscope as shown in Table 4-5 on page 4-12.
14. From the test oscilloscope, record the CH 1 High amplitude of the digital waveform. The value is approximately 400 mV.

15. In the test oscilloscope Trigger menu, set the polarity to negative. After the measurement stabilizes, record the CH 1 Low amplitude of the digital signal waveform.
16. Add the absolute values of the low and high amplitudes of the waveform.
17. Check that the sum of the high and low amplitude measurements is within the range of 723 mV to 877 mV. The measurement uncertainty due the accuracy of the example test equipment is taken into consideration in this range to verify that the output is within the allowable limits of  $800\text{ mV} \pm 100\text{ mV}$ .

## Check the DSP 27 MHz Clock Frequency

Use the following procedure to check the oscillator frequency of the analyzer and generator DSP modules.

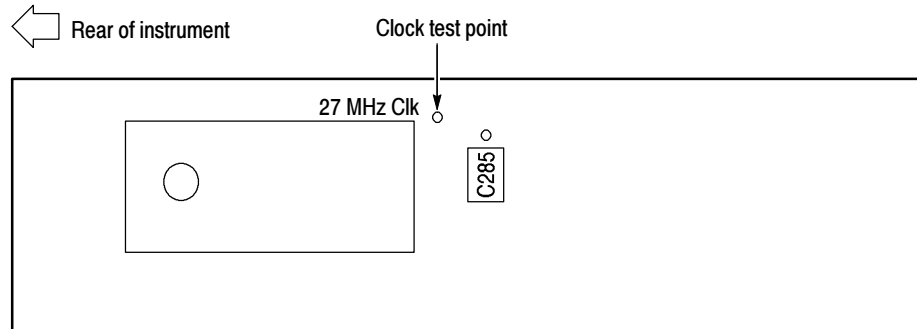
### Test Equipment Setup

1. Set up the test equipment.

**Table 4-14: Frequency counter setup**

Feature	Mode	Status
Measure	Freq	
Limits	Run	
Channel 1		Connected
Trigger	Sensitivity	OFF
Input impedance	50 $\Omega$ /1 M	1 M $\Omega$
Input coupling	DC/AC	AC
Attenuation	x10 Atten	OFF
Filter	10 kHz Filter	OFF

2. Be sure that you wear a static grounding wrist strap.
3. Turn off power to the system.
4. Remove the PQA300 cabinet. Refer to *Removing the Cabinet* on page (6-5) for the procedure.
5. Connect a 1 M $\Omega$  probe to the frequency counter Channel 1 input connector.
6. Connect the probe ground lead to chassis ground.
7. Carefully touch the probe tip to the oscillator 27 MHz Clk test point of the generator DSP module. See Figure 4-25 for the location of the test point.



**Figure 4-25: Oscillator test point for frequency check**

---

**NOTE.** *This oscillator is temperature sensitive. Allow the system to warm up for 20 minutes before checking the frequency.*

---

8. Check the frequency counter for a reading of 27 MHz  $\pm$  27 Hz (26,999,973 to 27,000,027 Hz).
9. Move the counter probe tip to the analyzer DSP oscillator test point.
10. Check the frequency counter for a reading of 27 MHz  $\pm$  27 Hz (26,999,973 to 27,000,027 Hz)
11. Disconnect the test equipment and reinstall the PQA300 cabinet.





# **Adjustment Procedures**



# Adjustment Procedures

This section provides the recommended field adjustments for the PQA300 Picture Quality Analysis System.

## Equipment Required

Table 5-1 lists the test equipment needed to perform the adjustment procedure. The table identifies examples and provides the minimum tolerances, where applicable. If equipment is substituted, it must meet or exceed the tolerances listed.

**Table 5-1: Required equipment list**

Test equipment	Characteristic	Example
Frequency counter with 1 M $\Omega$ test probe	Frequency 100 MHz, 10-digit readout, accuracy 0.1 ppm. (Referenced to WWV, GPS, or with a high accuracy time base.)	Hewlett-Packard Model 53131A
Screwdriver with T-15 Torx Tip		Standard tool
Adjustment tool	Plastic handle, small metallic bit. Less than three inches overall.	Tektronix part number 003-1433-01
Digital Voltmeter	DC 1 V to 20 V, accuracy $\pm 0.5\%$	Tektronix DM2510 Programmable Multimeter
PCI circuit board extender	5 V, 32-bit PCI bus extender card	Kaitek Engineering Model 34-06-TP Tektronix part number 018-0226-00

## DSP 27 MHz Oscillator Frequency Adjustment

Use the following procedure to adjust the oscillator frequency of the analyzer and generator DSP modules.

---

**NOTE.** *It is not necessary to do this adjustment, and it should not be attempted, if the oscillator frequency is within specification when checked in the performance verification procedure.*

---

If the oscillator is not working or cannot be adjusted, refer to the *Maintenance* section on page 6-8 for PQA300 module replacement instructions.

**Test Equipment Setup**

1. Set up the test equipment.

**Table 5-2: Frequency counter setup**

Feature	Mode	Status
Measure	Freq	
Limits	Run	
Channel 1		
	Trigger Sensitivity	OFF
Input impedance	50 $\Omega$ /1 M	1 M $\Omega$
Input coupling	DC/AC	AC
Attenuation	x10 Atten	OFF
Filter	10 kHz Filter	OFF

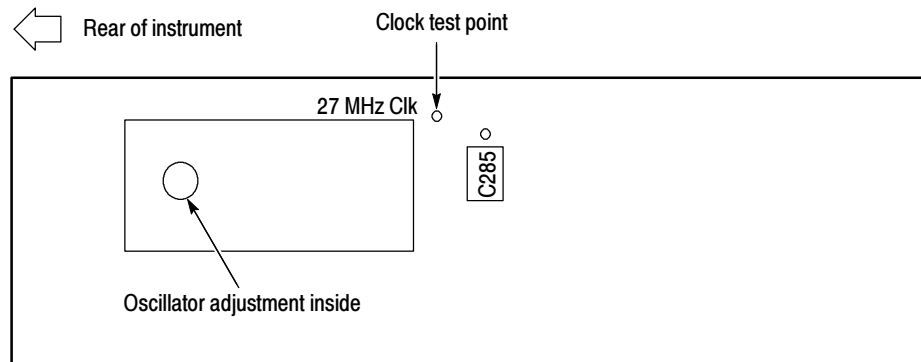
2. Be sure that you wear a static grounding wrist strap.
3. Turn off power to the instrument.
4. Remove the PQA300 cabinet and circuit board retainer. Refer to the *Removing the Cabinet* on page 6-5 for the procedure.
5. Remove the analyzer DSP module. For the removal procedure, refer to *Removing a Plug-In Module* on page 6-8.
6. Insert the PCI circuit board extender into the analyzer DSP module slot.
7. Insert the analyzer DSP module in the PCI extender board connector.
8. Turn the power to the instrument back on and wait for the initialization process to complete. It is not necessary to log in or start the PQA300 application.

---

**NOTE.** *This adjustment is temperature sensitive. The instrument should be allowed to warm up for 20 minutes before attempting to make the final adjustment to the limits given in step 12. This centers the operating range of the oscillator so that it will remain in specification with aging and temperature variations.*

---

9. Connect a 1 M $\Omega$  probe to the frequency counter Channel 1 input connector.
10. Connect the probe ground lead to chassis ground of the instrument.
11. Carefully touch the probe tip to the oscillator 27 MHz Clk test point of the analyzer DSP module. See Figure 5-1 for the test point location.



**Figure 5-1: 27 MHz clock test point for frequency adjustment**



**CAUTION.** When inserting the metal bit of the adjustment tool in the oscillator adjustment access hole, do not let it slip off the oscillator adjustment. The metal tip can possibly short the +5 V to ground and cause an inductor on the reverse side of the board to open.

12. Adjust the frequency counter for a reading of 27 MHz  $\pm$  5 Hz (26,999,995 to 27,000,005 Hz).

**NOTE.** The oscillator frequency specification is  $\pm$  27 Hz, but you must adjust the frequency to  $\pm$  5 Hz or less to allow for temperature variations while operating.

13. Turn off power to the PQA300.
14. Remove the analyzer DSP module from the PCI extender board.
15. Remove the extender board from the backplane board connector.
16. Reinsert the analyzer DSP module in the backplane slot.
17. Align the module connector with the backplane connector and press down firmly to seat the module.
18. Reinstall the module hold-down screw.
19. Remove the generator DSP module.
20. Insert the PCI circuit board extender into the generator DSP module slot.
21. Insert the generator DSP module in the PCI extender board connector.
22. Turn the power to the instrument back on and wait for the initialization process to complete, and wait a few minutes for the oscillator temperature to stabilize.

23. Touch the frequency counter probe tip to the generator DSP 27 MHz Clk test point.
24. Adjust the frequency counter for a reading of 27 MHz  $\pm$  5 Hz (26,999,995 to 27,000,005 Hz).
25. Turn off power to the PQA300.
26. Remove the generator DSP module from the PCI extender board.
27. Remove the extender board from the backplane connector.
28. Reinsert the generator DSP module in the backplane module slot.
29. Align the module connector with the backplane connector and press down firmly to seat the module.
30. Reinstall the module hold-down screw.

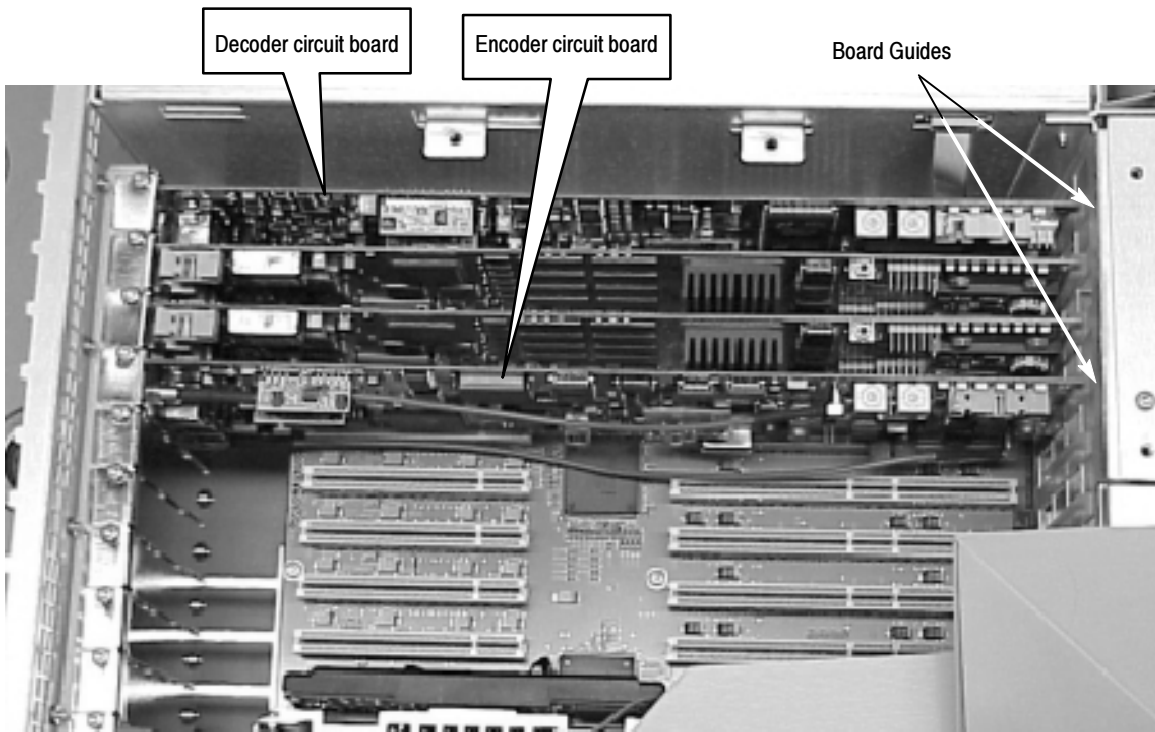
This completes the adjustment procedure for the DSP modules.

## Encoder Auto Cal

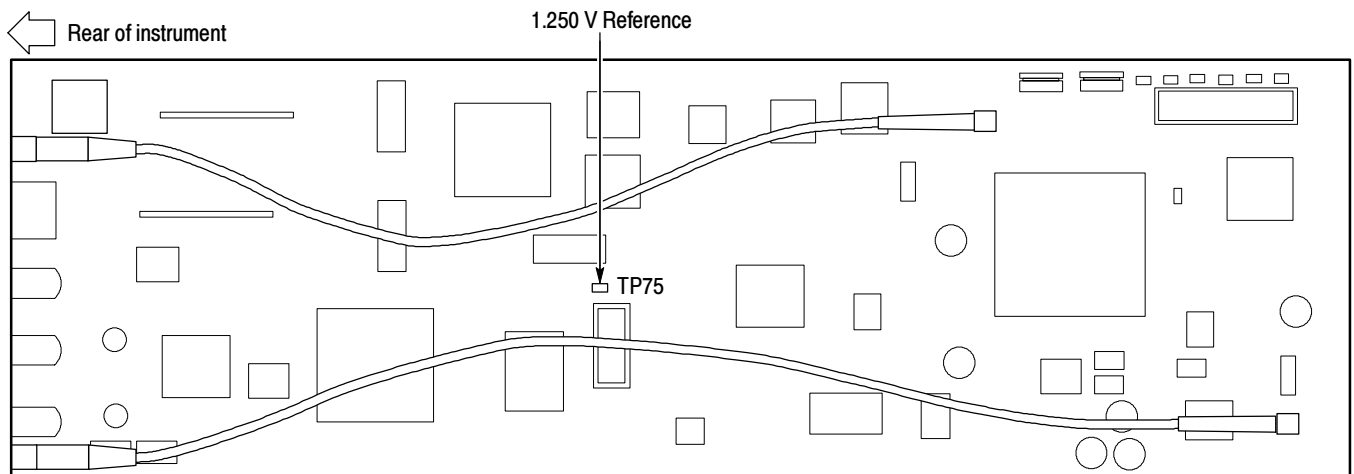
The adjustment procedure for the encoder module consists of checking the reference voltage for the correct level and running the encoder auto calibration routine. The automatic calibration routine compensates the adjustments of the encoder module for temperature changes and aging. Typically, you should use this feature about every six months to maintain optimum encoder operation. Use the following procedure to perform the encoder module adjustments.

### Check the Encoder Reference Voltage

1. Locate the 1.250 V reference voltage test point TP75. The loop of the test point is near the center of the encoder board just above the gray plastic shell of a test connector. Figure 5-2 shows the location of the encoder circuit board and Figure 5-3 shows the location of the test point.
2. Set the DVM to measure DC voltage on the 2 V range.
3. Connect the - (GND) lead of the DVM to instrument chassis and the + lead to TP75.
4. Check for a reference voltage of 1.250 V  $\pm$  3 mV.
5. If the reference voltage is correct, continue with the encoder auto-calibration routine. If the reference voltage is out of tolerance, do not run the auto-calibration routine. Refer the problem to a qualified service person.
6. Replace the PQA300 cabinet to allow the operating temperature to stabilize.



**Figure 5-2: Locating the decoder and encoder circuit boards**



**Figure 5-3: Location of TP75, the 1.250 V encoder auto-cal reference test point**

### Run the Encoder Auto Calibration Routine

1. Allow the PQA300 to completely warm up (about 20 minutes) before using the automatic calibration feature. This permits all the circuitry to stabilize. The auto-cal adjustments are then optimized for the normal operating temperature.
2. Click the Other soft key to display the selection menu, and then click on Hardware Settings and Diags to display the Hardware Settings menu shown in Figure 5-4. You will get a message telling you that all PQA300 applications must be stopped to continue. Click OK to continue.

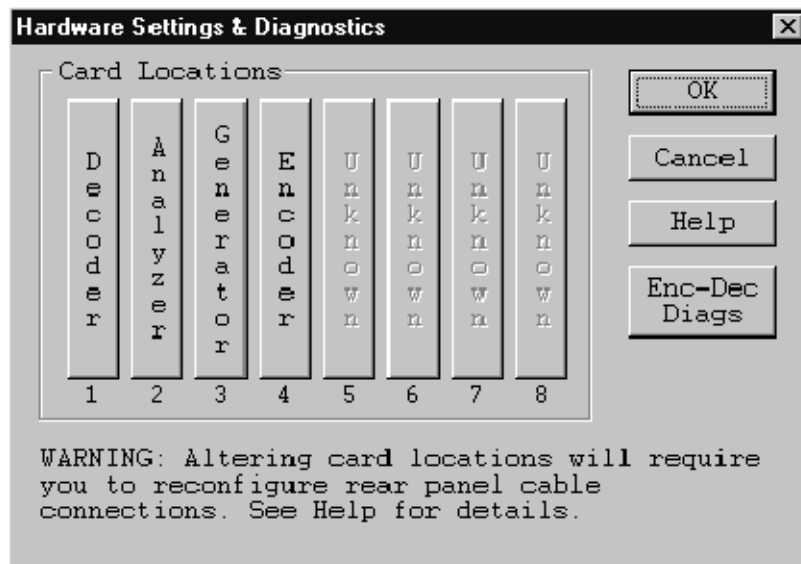
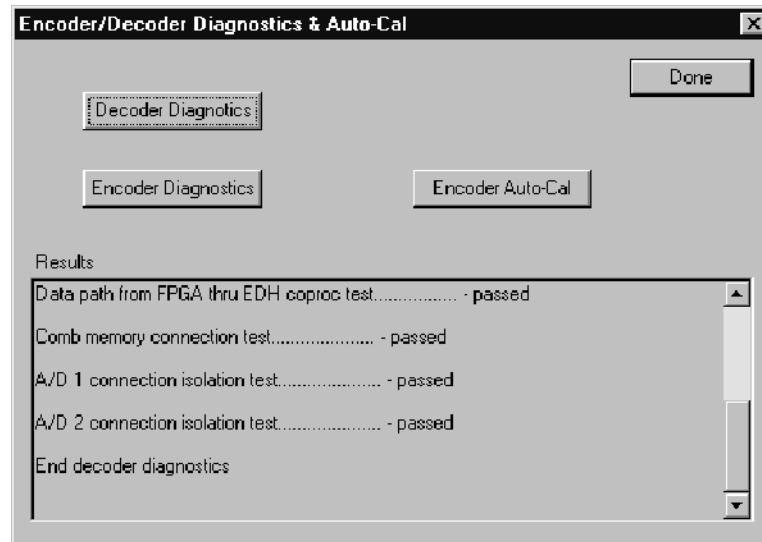


Figure 5-4: Hardware settings menu

3. Click on the Enc-Dec Diags soft key to display the Encoder and Decoder Diagnostics menu shown in Figure 5-5.





**Figure 5-5: Encoder/Decoder diagnostics and Encoder Auto-Cal**

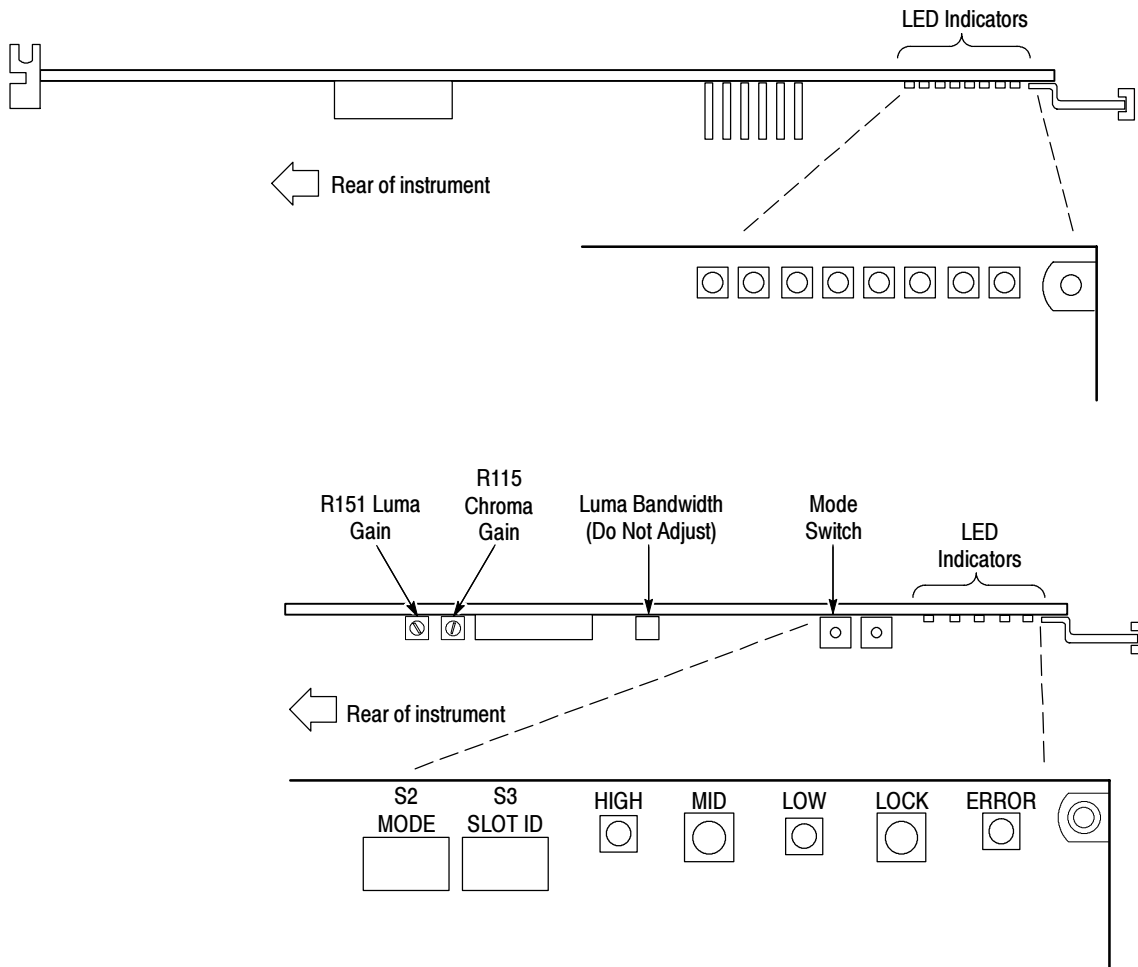
4. Click the Encoder Auto-Cal selection.
5. After the auto calibration has finished, run the Encoder Diagnostics to check for pass or fail of the diagnostic tests.
6. If the encoder shows diagnostic failures after the auto calibration, refer your PQA300 system to a qualified service person for repairs.

## Decoder Board Adjustments

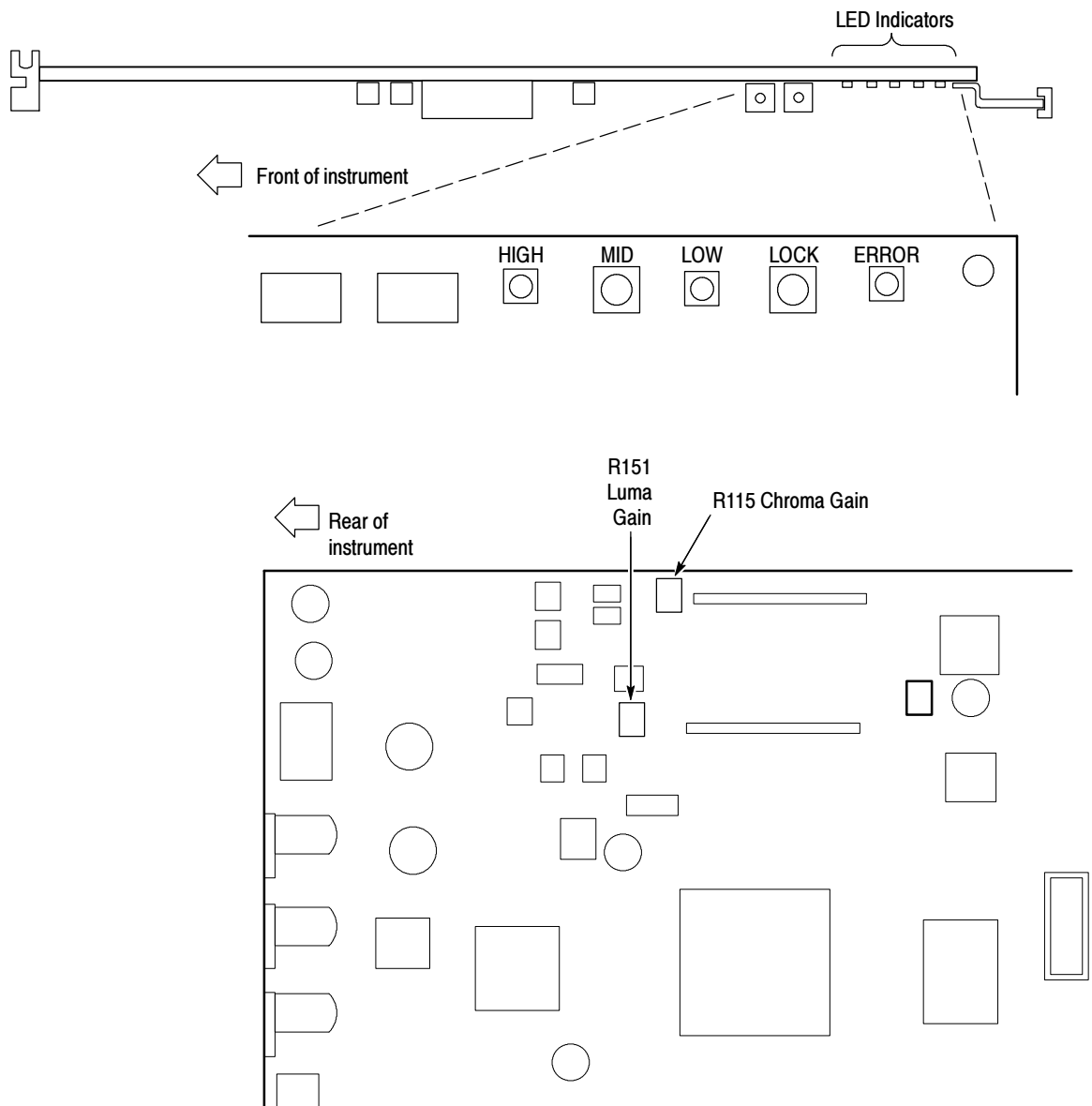
The hardware of the decoder module supports a field calibration procedure. The adjustments of the Luma and Chroma gain have built-in indicators for showing the accuracy of the adjustments.

### Adjust Luma Gain

1. Set the Mode switch to position 1. See Figure 5-6.
2. Adjust R151 Luma Gain (see Figure 5-7) until the MID (green) LED indicator is on and the LOW and HIGH LED indicators are either equal or off. The Luma Gain adjustment is about one third of the way down from the top of the board.



**Figure 5-6: Decoder board LED indicator locations**



**Figure 5-7: Decoder board adjustment locations**

**Adjust Chroma Gain**

1. Set Mode switch to position 2.
2. Adjust R115 Chroma Gain until the MID (green) LED indicator is on and the LOW and HIGH LED (red) indicators are equal or off. The Chroma Gain adjustment is at the top of the board.
3. Set Mode switch to 0 (normal run mode).
4. Check the blanking adjustment on the HIGH and LOW LED indicators. Both red LED indicators should be off but it is normal for them to blink occasionally as the blanking level is adjusted.

**Run the Decoder Diagnostic**

1. In the menu selections under the Other soft key, click the Hardware Settings & Diag selection. You will get a message telling you that all PQA300 applications must be stopped to continue. Click OK to continue.
2. From the Hardware Settings menu select ENC-DEC Diagnostics.
3. In the ENC-DEC Diagnostics menu select Decoder Diags.
4. Verify that all diagnostics pass. If they do not, refer your instrument to a qualified service person for repairs.
5. Disconnect all test equipment and reinstall the top instrument cover.

This completes the adjustments for the PQA300 system.



# Maintenance



# Maintenance

This section provides the service information for the PQA300 Picture Quality Analysis System. Information about the following topics is provided: Handling Static-Sensitive Components, Cleaning and Inspection, Removal and Replacement Instructions, Repacking for Shipment, and Obtaining Replacement Packaging.

## Preparation

These maintenance instructions are for qualified technicians. Be sure to read the Safety Summaries at the front of the manual before beginning service.

Prior to removing the covers from the instrument, read *Handling Static-Sensitive Components*.

## Handling Static-Sensitive Components

This instrument contains electrical components that are susceptible to damage from static discharge. Static voltages from 1 kV to 30 kV are common in unprotected environments. Table 6-1 shows the relative static discharge susceptibility of various semiconductor classes.

**Table 6-1: Static susceptibility**

Semiconductor class	Voltage
ECL	200 V - 500 V
Shottky Signal Diodes	250 V
Shottky TTL	500 V
HF Bipolar Transistors	400 V - 600 V
JFETs	600 V - 800 V
Linear Microcircuits	400 V - 1000 V
Low Power Schottky TTL	900 V
TTL	1200 V

Observe the following precautions to avoid damaging static-sensitive devices:

1. Minimize handling of static-sensitive components.
2. Transport and store static-sensitive components or assemblies in their original containers, on a metal rail, or on conductive foam. Label any package that contains static-sensitive components or assemblies.
3. Discharge the static voltage from your body by wearing a wrist grounding strap when handling static-sensitive components. Service assemblies containing static-sensitive components at static-free work stations.
4. Remove any device capable of generating or holding a static charge from the work station surface.
5. Whenever possible keep the component leads shorted together.
6. Pick up components by the body, never by the leads.
7. Do not slide components over any surface.
8. Avoid handling components in areas where the floor or work surface covering is capable of generating a static charge.
9. Use a soldering iron that is connected to earth ground.
10. Use only special antistatic suction or wick-type desoldering tools.

## Cleaning and Inspection

Preventive maintenance consists of cleaning and visual inspection. The schedule depends on the severity of the operating environment. Under average conditions, perform preventive maintenance after 2000 hours of operation.

Clean the entire Test System often enough to prevent dust and dirt from accumulating. Dirt can act as a thermal insulating blanket that prevents effective heat dissipation. In addition, dust buildup can provide high-resistance electrical leakage paths between conductors or components in a humid environment.

**Exterior.** Cleaning the exterior consists of an occasional wiping of the outside surfaces with a damp soft cloth. Do not use commercial cleaners because they could discolor or damage the finish.

Check all the instrument air vents on a regular schedule to ensure that there is not a dust buildup that could impede the flow of cooling air.



**Keyboard.** The (optional) keyboard may require occasional cleaning to remove lint or oil buildup. Use the following procedure to clean the keyboard.

1. Turn off the main power switch.
2. Unplug the keyboard from the instrument.
3. Clean all lint and loose debris from the keyboard with either clean, dry, low velocity air or with a clean, soft brush.
4. Clean the external surfaces with a soft cloth dampened with a solution of mild detergent and water. Do not allow solution to run into the keyboard.



---

**WARNING.** To avoid any potential of electrical shock, disconnect power before removing the instrument side panels.

---

**Interior.** Interior cleaning is not recommended, but if necessary, use low-velocity, dry air to blow away dust or lint. If air alone does not remove all the dust and lint, use a soft brush to complete the task. Use extreme care not to disturb components on the plug-in circuit boards during cleaning.



---

**CAUTION.** This instrument contains static sensitive devices that can be damaged by static discharge. Wear a wrist grounding strap when working on or with modules inside the instrument cabinet.

---

## Removal and Replacement Instructions

The following procedures tell you how to remove and replace the PQA300 program monitor modules. Part numbers for the modules are in the *Replaceable Parts List*. In compliance with the EISA standard the PQA300 Picture Quality Analysis System modules are in the mainframe card bay.

### Replaceable PQA300 Modules

The standard PQA300 Picture Quality Analysis System consists of the following replaceable components:

- Program Monitor DSP module (1 to 8 modules)
- Composite decoder module (PQA3F01) (1 to 4 modules)

The mainframe consists of the following replaceable components:

- Processor module (controller board)
- I/O module (controller input/output board)

- Front panel Interface module
- Two SCSI hard disk drives
- Power supply module
- Front panel keypad module (circuit board only, no keypad)
- Floppy disk drive/CDROM drive assembly
- Backplane circuit board

### **Recommended Tools**

The following tools are recommended for PQA300 Picture Quality Analysis System assembly removal and replacement:

- An anti-static wrist strap for safe handling of assemblies containing static sensitive devices.
- A screwdriver with T10, T15, and T20 Torx tips to remove the cabinet cover and the module mounting screws.
- A 1/4 inch or larger flat tip screwdriver.
- An 8 inch adjustable wrench or appropriate size open-end wrench (an aid for cabinet removal).
- Smooth jaw pliers (example, KLEIN D306-51/2C).

### **Removing the Bezel Trim Ring**

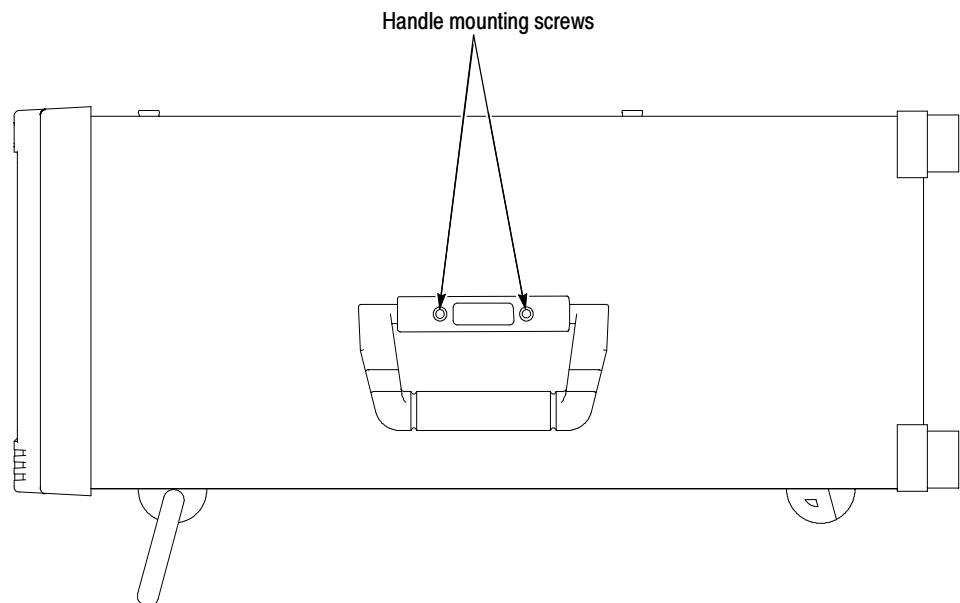
Remove the bezel trim ring to permit removal of the the keypad assembly, the interface circuit board, and the CD/floppy disk drive assembly. The front bezel snaps onto the chassis. There are three snaps across the top and three across the bottom. Remove the front panel bezel as follows:

1. Use smooth jaw pliers to grasp the On/Stby key and pull straight out on the key to disconnect the key cap from the switch.
2. Use your fingers to lift up on the back edge at the top of the bezel to release the bezel from the snaps. If you use a tool for leverage be careful not to bend the fingers of the EMI shielding strips.
3. After you have released the snaps across the top, pull the top of the bezel toward you slightly to clear the chassis. This should release the bottom of the bezel from the chassis.
4. Lift the bezel off the front of the chassis.

### **Removing the Cabinet**

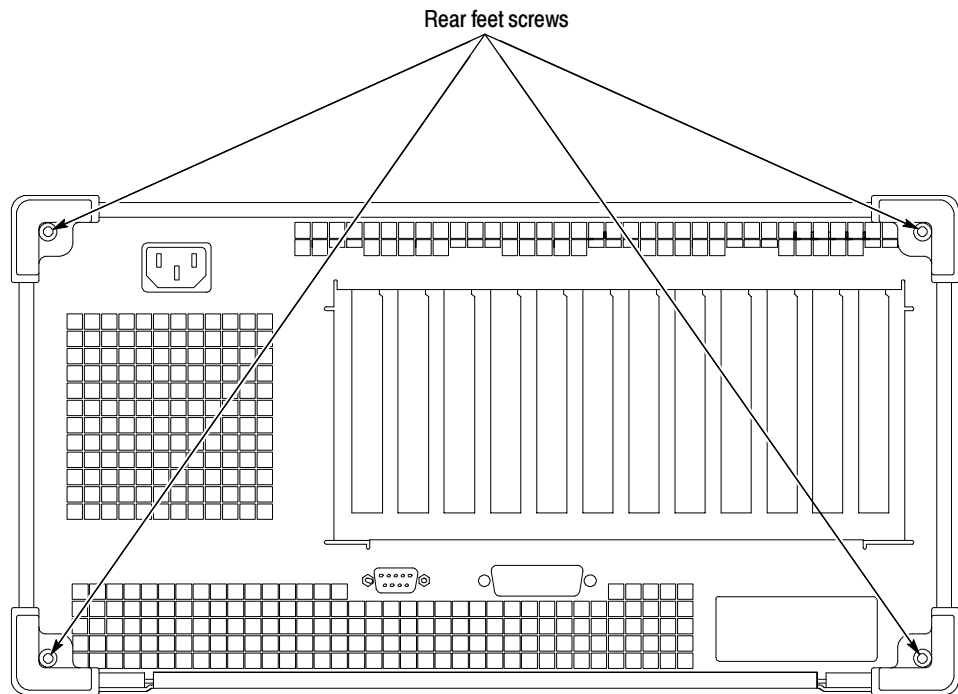
The cabinet must be removed to access any of the PQA300 application modules and to access the mainframe modules and cable connectors to the controller board. Use the following procedure to remove the cabinet:

1. Be sure that you are wearing a static grounding wrist strap.
2. Before removing the cabinet, shut down the PQA300 and unplug the power cord.
3. Disconnect any cables connected to the rear panel connectors of the PQA300 system. Note their locations for reinstallation.
4. Put the protective front cover on the PQA300 system and set the cabinet upright on the working surface with the rear panel up.
5. Remove the two screws from the handle on the left side of the cabinet (see Figure 6-1). These screws attach to post mounted on the power supply module.



**Figure 6-1: Right side handle screws**

6. Remove the screws from the four feet on the rear of the mainframe chassis.
7. Use either an adjustable wrench or appropriate size open end wrench as a lever to pry the cabinet loose from the chassis. Loosen each side alternately until the cabinet is released from the EMI gasketing.
8. Slide the cabinet up and off the chassis.



**Figure 6-2: Rear panel feet removal**



---

**CAUTION.** Use care when touching the EMI shielding strips around the front of the chassis. The fingers of the strip are easily bent and any protruding sharp edges become a potential cutting hazard when you handle the chassis to position it during the remaining remove and replace procedures.

---

### Replacing the PQA300 Cabinet

1. Place the protective front cover on the face of the PQA300.
2. Position the PQA300 face down on a stable working surface with enough head room to install the cabinet.
3. Position the cabinet correctly to install it, and slide the cabinet over the end of the mainframe chassis.
4. Slide the cabinet evenly down on the chassis making sure all the internal cables are clear and do not catch.
5. When the front of the cabinet comes in contact with the cabinet retaining tabs around the front of the chassis, make sure the edges of the cabinet go under the tabs. You may have to push on the sides of the cabinet to get all the edges under the tabs and over the EMI strips around the front of the chassis.

6. At the rear of the chassis, you may have to push on the sides of the cabinet to get the rear of the cabinet to fit over the edges of the chassis and EMI gasketing.
7. When the cabinet is completely in place on the chassis, install the four rear feet.
8. Position the handle on the left side of the chassis and replace the two screws that attach the handle to the chassis (see Figure 6-1).

### **Replacing the Bezel Trim Ring**

There are three snaps across the top and three across the bottom that hold the bezel to the cabinet. Replace the front panel bezel as follows:

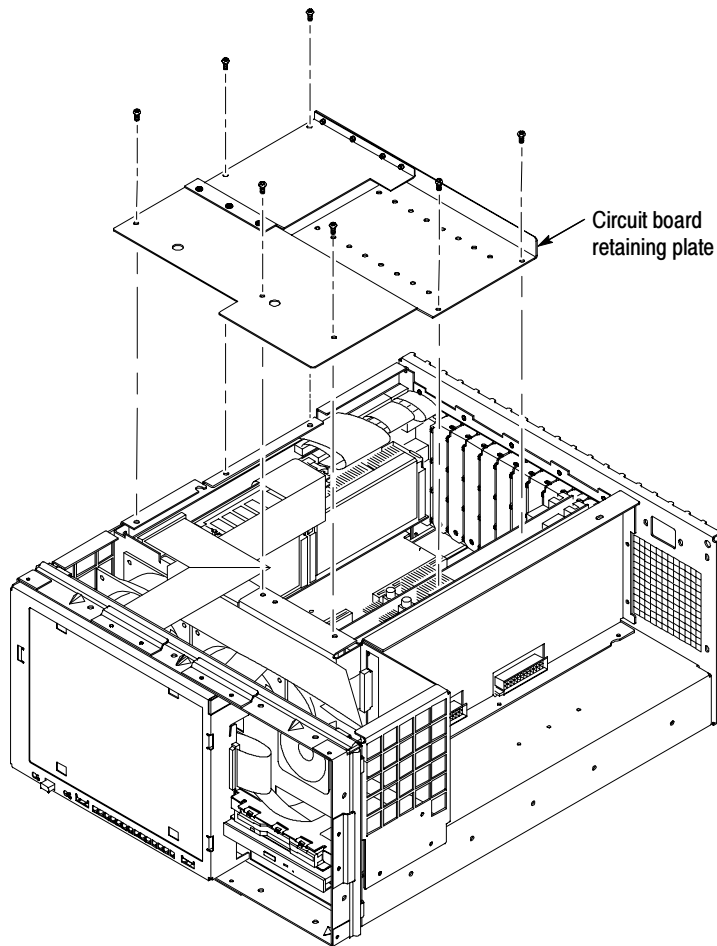
1. If the light pipes are out, replace them now. Insert the light pipes in the light-pipe holes and turn them clockwise until they snap into place.
2. Position the bezel trim ring over the front of the cabinet and engage the three snaps across the top of the cabinet first.
3. After you have engaged the snaps across the top, firmly press the bottom of the bezel onto the cabinet to engage the snaps across the bottom of the bezel.
4. Press on the top of the bezel again to make sure the top snaps are all completely engaged.
5. Using smooth jaw pliers to hold the key cap, position the On/Stby key cap on the switch shaft. Push straight in on the key cap to press it onto the switch shaft.

## Application Modules

The PQA300 plug in modules are located in the mainframe module bay. The SCSI hard disk drives are located in the mainframe bottom compartment. The following procedures start after removal of the cabinet from the mainframe.

### Removing a Plug-In Module

1. Remove the circuit board retaining plate (see Figure 6-3).
2. Remove the holding screws from the top and bottom of the plug-in module you are going to remove.
3. Carefully pull up on the module to loosen it from the backplane module connectors. You may have to alternate lifting on the front and the rear of the module to work it loose from the front connectors and the card bay.



**Figure 6-3: Circuit board retaining plate**

4. When the module is loose from the connector, lift the module out of the module bay.
5. Place the removed module on a static free work surface or in a anti-static protection bag.

### **Reinstalling a Plug-In Module**

1. Insert the module into the module bay at the correct slot position.
2. Carefully align the module edge connector with the backplane connectors.
3. Apply firm pressure to completely seat the module in the connectors.
4. Replace the module holding screws to hold the module in the card bay.
5. Torque the screws to 8 in-lbs.

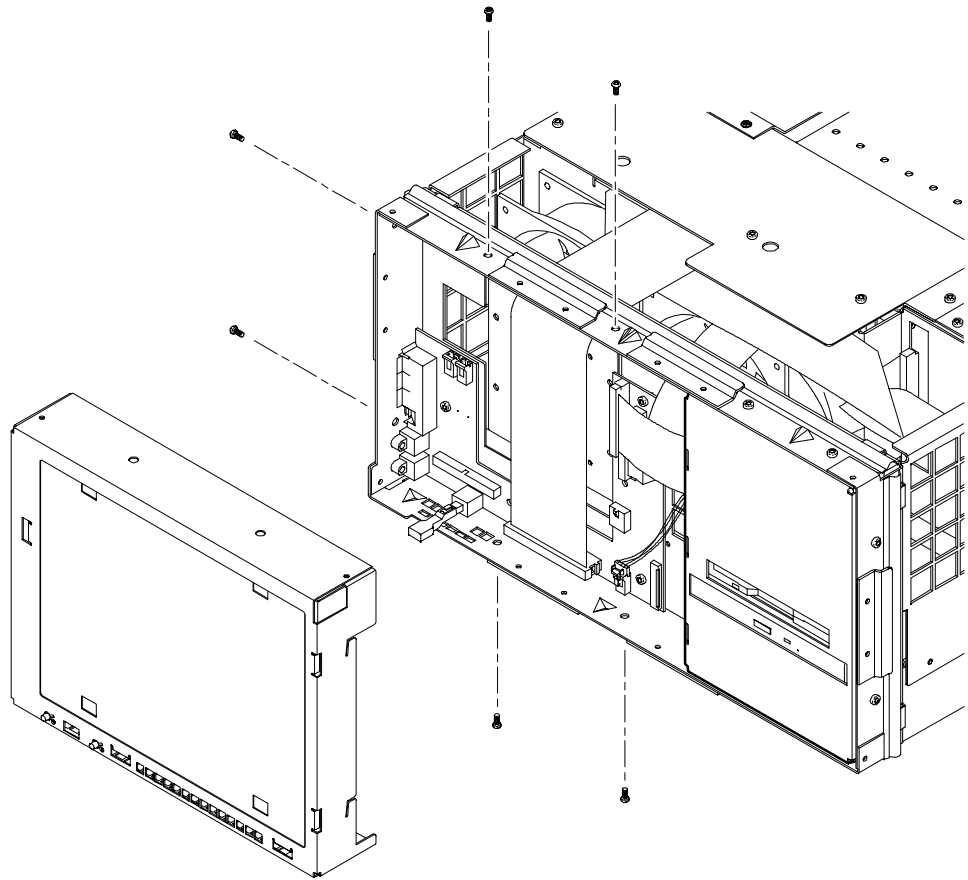
## **Mainframe Modules**

Removing the bezel permits access to the retaining screws that hold the front panel components in place so that you can remove and replace them without removing the mainframe cabinet. The standard instrument has a blank front panel. The local control option instrument has a flat-panel display and keypad installed. The procedures for these two configurations are similar; use the correct procedure for your PQA300 configuration.

### **Removing the Interface Circuit Board Cover**

Remove the front panel interface circuit board cover assembly as follows:

1. Remove the front panel bezel (see *Removing the Bezel Trim Ring* on page 6-4 for the removal procedure).
2. Remove the six screws attaching the front panel circuit board cover to the chassis. There are two screws at the top, two at the bottom, and two at the left side of the assembly (see Figure 6-4).
3. Pull the cover assembly away from the chassis.



**Figure 6-4: Front panel circuit board cover removal**

**Reinstalling the Front Panel Interface Circuit Board Cover**

Make sure all the cables to the interface assembly are properly connected before replacing the interface circuit board cover assembly. After that, use the following procedure to replace the cover assembly:

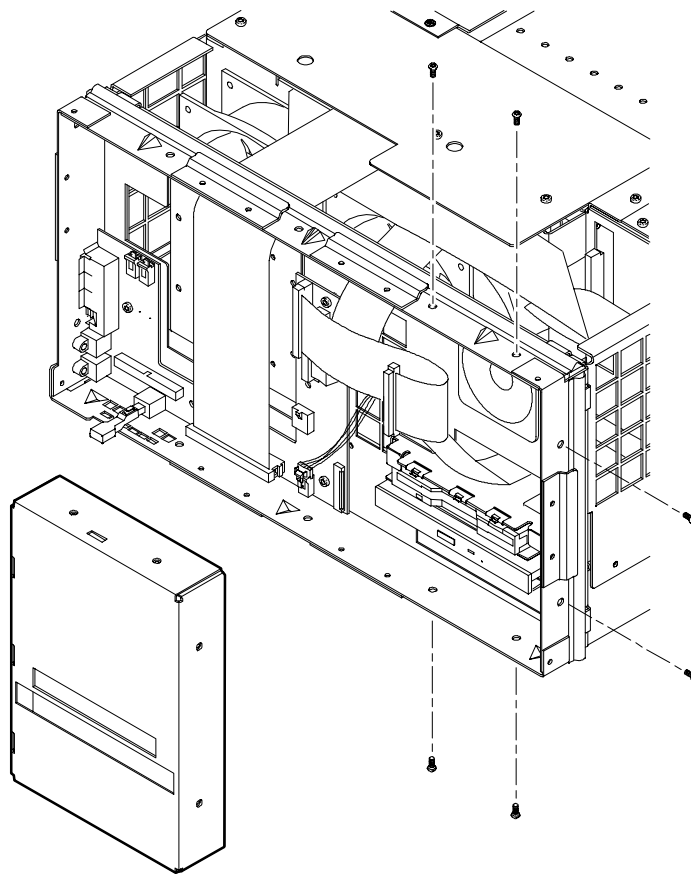
1. Carefully slide the cover assembly into the chassis to align it with the mounting screw holes.
2. Install the six attaching screws; two on the top, two on the side, and two on the bottom of the chassis. Torque to 8 in-lbs.



## Removing the Blank keypad Assembly

Remove the blank keypad circuit assembly as follows:

1. Remove the front panel bezel (see *Removing the Bezel Trim Ring* on page 6-4 for the removal procedure).
2. Remove the six screws holding the keypad assembly to the mainframe chassis. There are two across the top, two across the bottom, and two on the right side of the assembly (see Figure 6-5).



**Figure 6-5: Blank keypad assembly removal**

3. Slide the keypad assembly out of the chassis far enough to access the interconnection cable connector on the back of the keypad circuit board.
4. Disconnect the keypad interconnection cable to the interface circuit board from the keypad circuit board.

### **Replacing the keypad Assembly**

1. Position the keypad assembly to slide it into the chassis.
2. Connect the keypad assembly interconnection ribbon cable to the keypad connector on keypad circuit board.
3. Carefully slide the keypad assembly into place and align the mounting screw holes.
4. Install the six attaching screws.

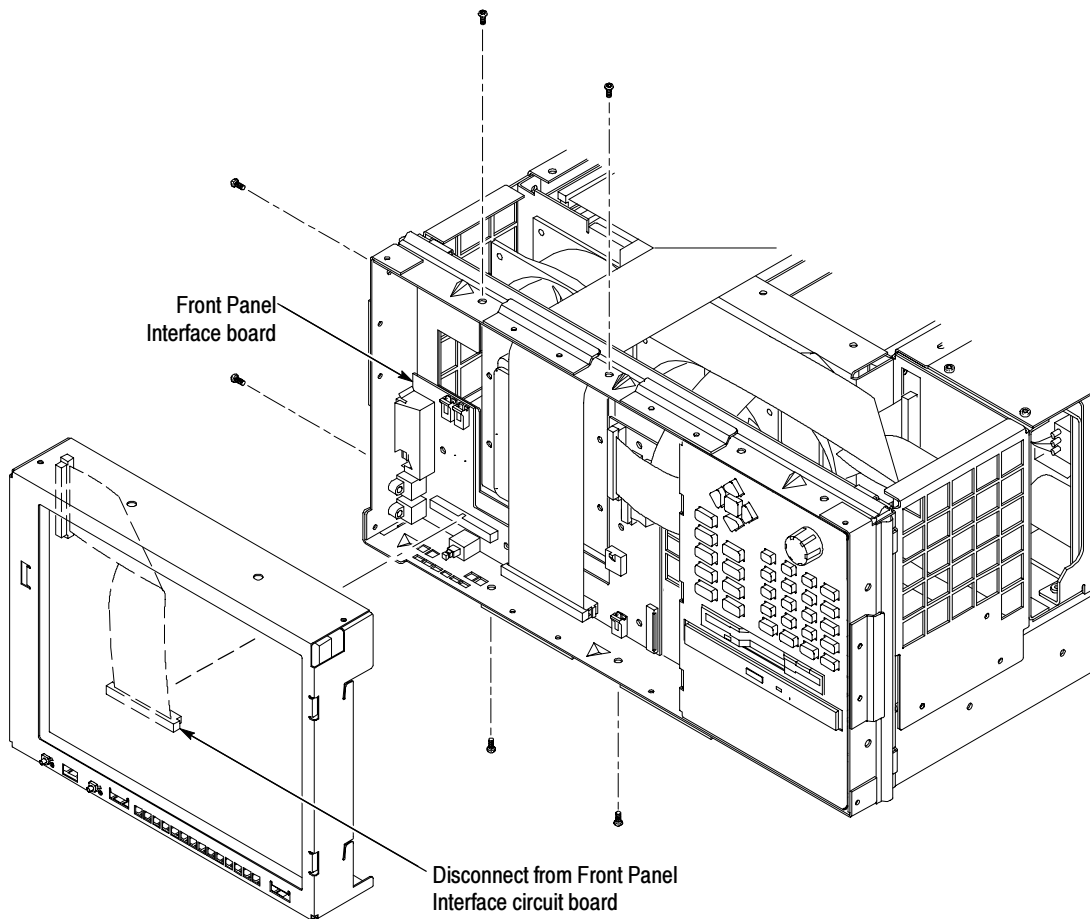
### **Removing the Flat Panel Display**

The flat panel display assembly of the PQA3FLC option comes as an assembled and tested unit. Remove the flat panel display assembly as follows:

1. Remove the front panel trim ring (see *Removing the Bezel Trim Ring* on page 6-4 for the removal procedure).
2. Remove the six screws attaching the display assembly to the chassis. There are two screws at the top, two at the bottom, and two at the left side of the assembly (see Figure 6-6).
3. Pull the display assembly away from the chassis to expose the connector to the front panel interface circuit board (see Figure 6-6).
4. Disconnect the ribbon cable connector from the front panel interface circuit board.

### **Reinstalling the Flat Panel Display**

1. Make sure that all the cables to the interface assembly are properly connected (see Figure 6-8).
2. Position the flat panel display with the display assembly interconnection near the front panel interface circuit board. Connect the cable to the display connector on the front panel interface circuit board.
3. Carefully slide the display assembly into the chassis to align it with the mounting screw holes.
4. Install the six attaching screws; two on the top, two on the side, and two on the bottom of the chassis.

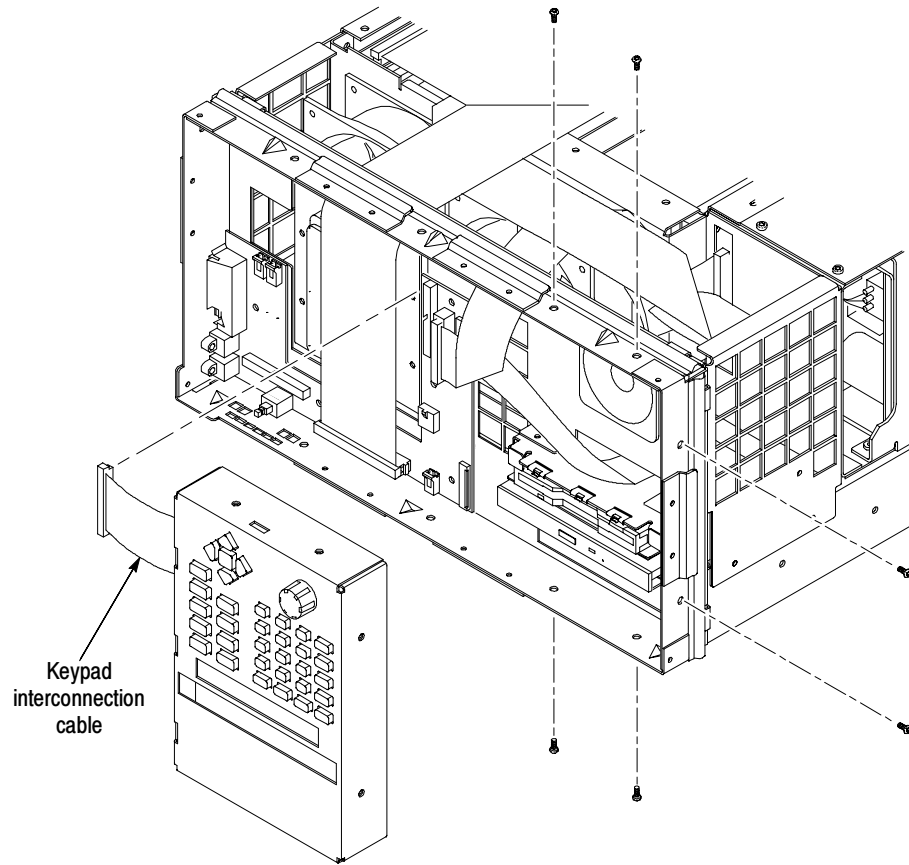


**Figure 6-6: Flat panel display removal**

### **Removing the Key Pad Assembly**

After removing the front panel bezel and flat panel display assembly, remove the front panel keypad assembly as follows:

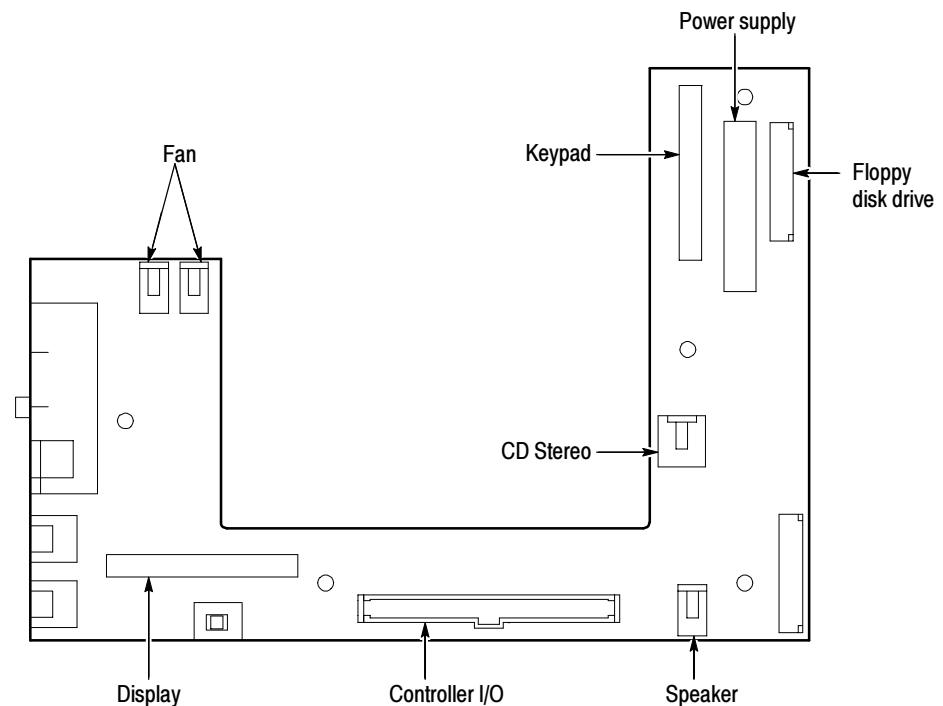
1. Remove the six screws holding the keypad assembly to the mainframe chassis. There are two across the top, two across the bottom, and two on the right side of the assembly (see Figure 6-7).
2. Disconnect the keypad interconnection cable from the front panel interface circuit board.
3. Slide the keypad assembly out of the chassis.



**Figure 6-7: Keypad assembly removal**

**Replacing the Key Pad Assembly**

1. Position the keypad assembly to slide it into the chassis.
2. Carefully slide the keypad assembly into place and align the mounting screw holes.
3. Connect the keypad assembly interconnection ribbon cable to the keypad connector on the front panel interface circuit board (see Figure 6-8).
4. Install the six attaching screws.



**Figure 6-8: Front panel interface circuit board connectors**

### Removing the CD and Floppy Disk Drive Assembly

The cabinet, front bezel, and keypad assembly must be uninstalled to remove the CD and disk drive assembly for service. The front panel interface cover or the flat panel display assembly must be removed only if you need to change the floppy disk drive interconnection cable or the CD audio cable. Remove the CD and Floppy Disk drive assembly as follows:

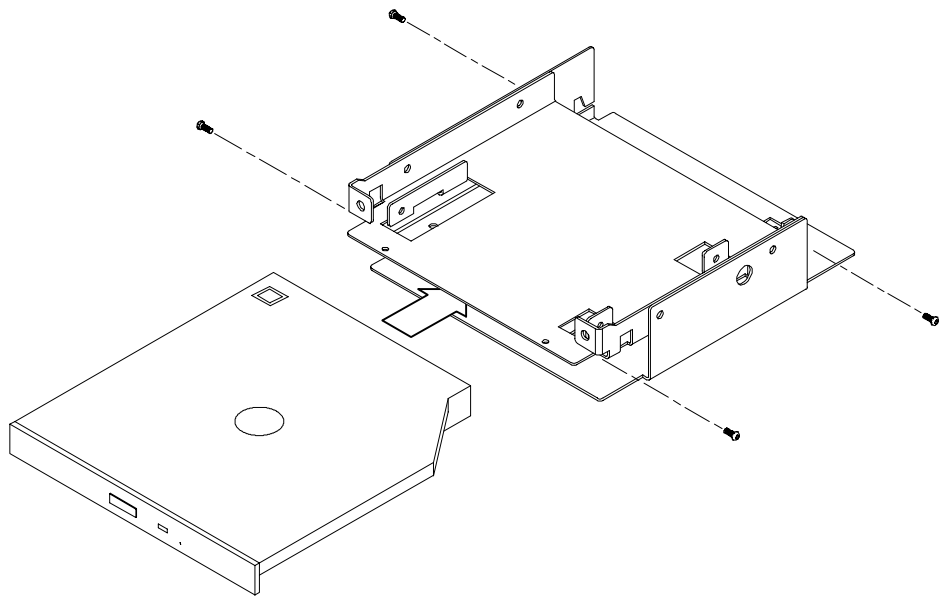
1. Remove the mainframe cabinet (see *Removing the Cabinet* on page 6-4 for the removal procedure).
2. Remove the front panel bezel (refer to *Removing the Bezel Trim Ring* on page 6-4 for the removal procedure).
3. Remove the front panel interface circuit board cover or the flat panel display assembly as appropriate (refer either to *Removing the Interface Circuit Board Cover* on page 6-9 or to *Removing the Flat Panel Display* on page 6-12).
4. Remove the keypad assembly (refer either to *Removing the Blank Key Pad Assembly* on page 6-11 or to *Removing the Key Pad Assembly* on page 6-13 for the removal procedure).
5. Remove the three screws attaching the CD and Floppy Disk Drive assembly to the chassis. There are two screws on the front of the assembly and one on the rear inside the front panel compartment of the chassis.

6. Disconnect the floppy drive cable from the floppy drive connector. Lift up the locking latch on the floppy drive connector to release the interconnection cable and pull up on the cable to separate it from the connector.
7. Disconnect the audio cable from the CD drive four pin connector (see Figure 6-11).
8. Disconnect the CD drive cable from the Controller board.
9. Disconnect the CD drive cable from the CD drive connector adapter board.
10. Slide the CD and Floppy Disk Drive assembly out through the front of the chassis. You may have to lift the front of the assembly slightly to clear the EMI shielding fingers.

### Removing and Replacing the CDROM Drive

The floppy disk drive and the CD drive are assembled in the same unit, but can be separately replaced.

1. Remove the four crosstip screws that hold the CD drive to the chassis.
2. Slide the CD drive out of the lower bay of the CD and floppy drive chassis.



**Figure 6-9: Chassis screw locations for CD drive**

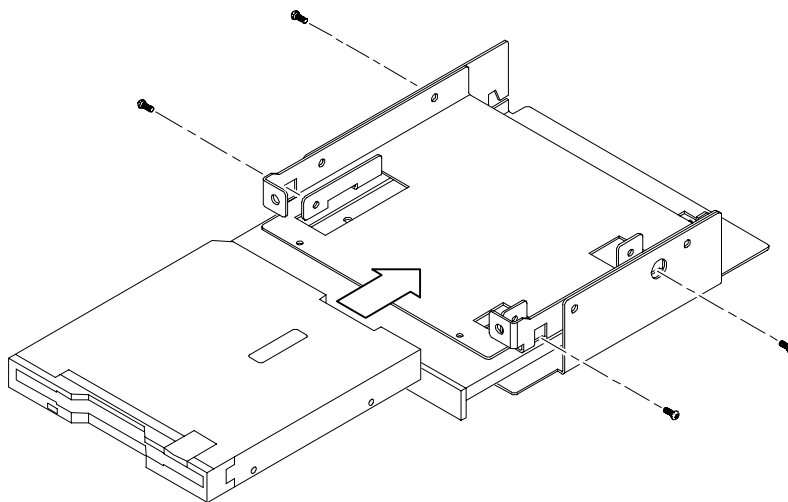
**Reinstall the CD Drive.**

1. Install the CD connector adaptor board.
2. Insert the CD drive into the lower bay of the CD and floppy drive chassis.
3. Align the CD drive mounting holes with the chassis holes.
4. Attach the CD drive to the chassis with four crosstip screws. Torque the screws to 2 in-lbs.

**Removing and Replacing the Floppy Disk Drive**

The floppy disk drive and the CD drive are assembled in the same unit, but can be separately replaced.

1. Remove the four cross tip screw holding the floppy disk drive to the assembly.
2. Lift the floppy disk drive up off the chassis as shown in Figure 6-10.



**Figure 6-10: Chassis screw locations for the floppy disk drive**

**Replace the Floppy Disk Drive.**

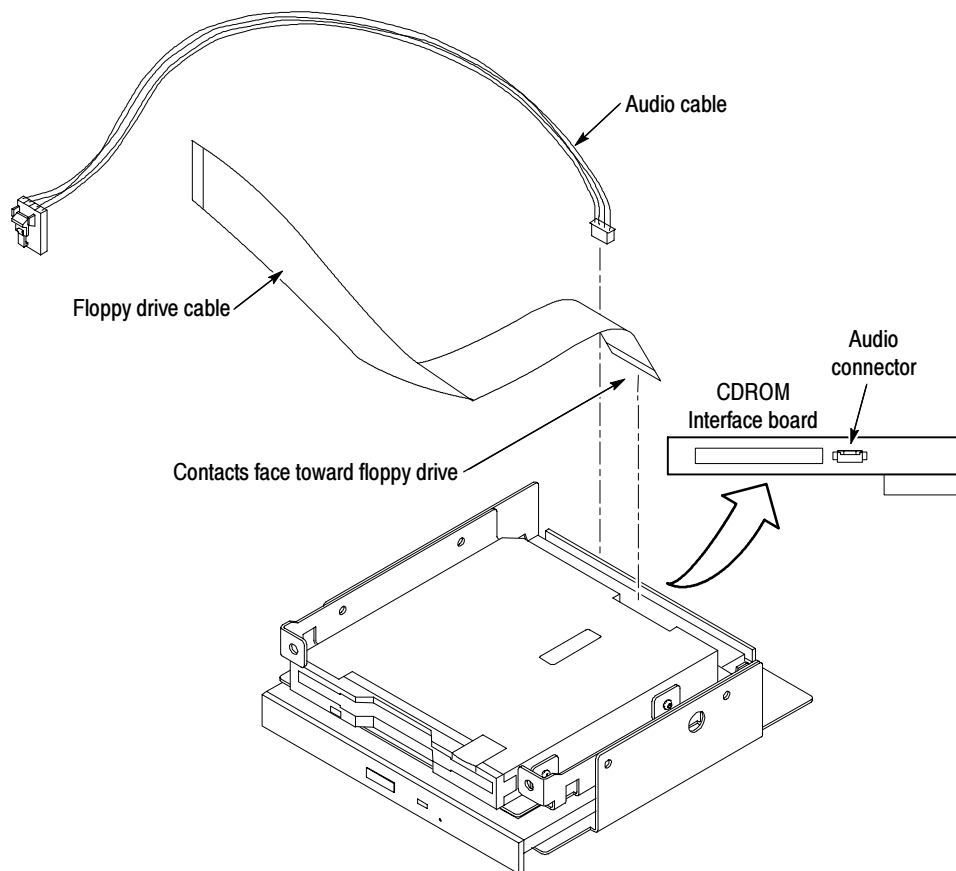
1. Place the replacement floppy drive onto the chassis / CD drive as shown in Figure 6-10.
2. Attach the floppy drive to the chassis with three crosstip screws. Torque each screw to 2 in-lbs.

### **Reinstalling the CD and Floppy Disk Drive Assembly**

When the CD and Floppy drive assembly is assembled, it can be reinstalled into the chassis.

1. Align the assembly with the slot in the chassis.
2. Slide the assembly part way into the compartment and install the CD cable. Connect the CD drive cable to the CD drive connector adapter board.
3. Attach the audio cable to the CD drive four pin connector.
  - a. Align the audio cable white colored dot with pin 1 of the CD drive four pin connector.
  - b. Plug the audio cable onto the CD drive connector (see Figure 6-11).
4. Attach the floppy drive cable to the floppy drive connector.
  - a. Lift up the floppy drive connector locking latch.
  - b. With the contacts of the short end of the floppy drive cable facing towards the floppy drive, insert the cable into the floppy drive connector as shown in Figure 6-11.
  - c. Support the edge of the circuit board and push the locking latch closed.
5. Line up the attaching screw holes and install the three attaching screws, two in the front and one in the rear of the assembly.





**Figure 6-11: Floppy disk drive and CD audio connector installation**

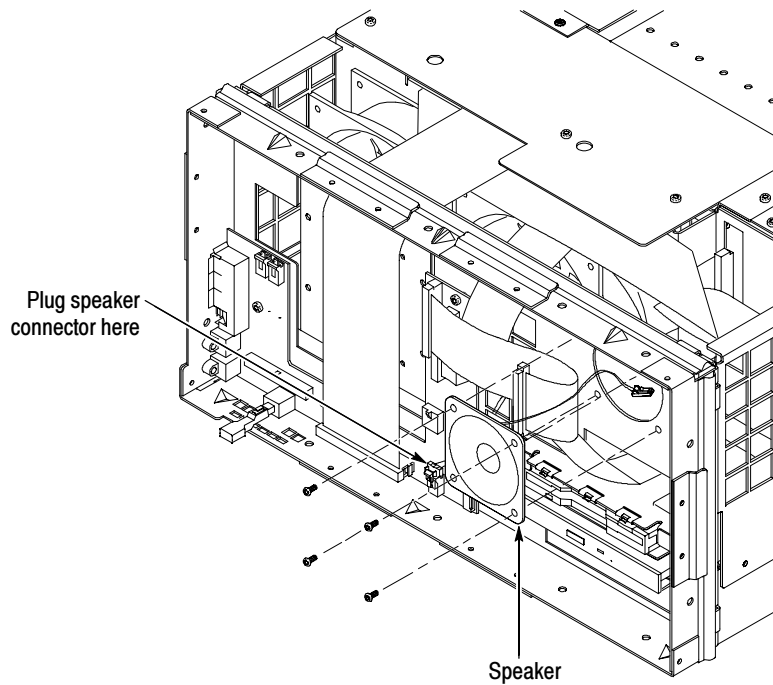
### Speaker Removal

The front bezel, front panel interface cover, and keypad assembly must be uninstalled to remove the speaker for replacement.

1. Remove the front panel bezel (refer to *Removing the Bezel Trim Ring* on page 6-4 for the removal procedure).
2. Remove the front panel interface circuit board cover (refer to *Removing Interface Circuit Board Cover* on page 6-9).
3. Remove the blank keypad assembly (refer to *Removing the Blank Key Pad Assembly* on page 6-11).
4. Disconnect the speaker connector from the front panel interface board (see Figure 6-22 on page 6-33).
5. Remove the four T15 screws that attach the speaker to the chassis and remove the speaker from the chassis. Note the routing of the speaker cable for reinstallation.

### Speaker Replacement

1. Route the speaker wire harness through mainframe chassis hole as shown in Figure 6-12.
2. Attach the speaker to the chassis with four T15 screws. Torque the screws to 8 in-lbs.



**Figure 6-12: Speaker installation and fan locations**

3. Route the speaker wire harness through the top-left opening in the front ventilation holes.
4. Reconnect the speaker wire to the front panel interface board Speaker connector J980 (see Figure 6-22 on page 6-33).

## Removing and Replacing the Dual SCSI Hard Disk Drives

The disk drives are installed in the lower compartment of the mainframe chassis. The mainframe cabinet must be removed to access the disk drive assemblies.

1. Be sure to wear a static grounding wrist strap.
2. Shut down the mainframe and unplug the power cord.
3. Remove the mainframe cabinet (see *Removing the Cabinet* on page 6-5 for the removal procedure).
4. Place the mainframe chassis on the work surface so that the bottom side with the SCSI disk drive assembly is facing up.
5. Disconnect the SCSI disk drive cable from both hard disk drives. Unclip the cable from the hold-down clips on the assembly plate. Note the routing and cable dress for reinstallation.
6. Disconnect the power supply cable from both hard disk drives.
7. Remove the six T-15 Torx screws that hold the assembly plate to the mainframe chassis and lift the hard drive assembly out of the main frame.

**Reinstall the Disk Drive Assembly.** The PQA300 has two SCSI drives. If replacement is necessary, one is replaced with a programmed hard disk drive, the other is replaced with an unprogrammed (blank) hard disk drive. The part numbers for both disk drives (programmed and unprogrammed) are in the *Replaceable Part List* section of this manual. The programmed disk drive has a sticker with its version number on the outside to identify it from the unprogrammed disk drive.

The drives have unique jumper settings, which are only visible from the underside. The jumpers set a unique address for the SCSI devices. The jumper configuration is as follows:

Programmed drive jumper configuration:

- Connector J4: Jumper on row 5 only.
- Connector J6: All jumpers removed.

Unprogrammed drive jumper configuration:

- Connector J4: Jumpers on rows 4 and 5.
- Connector J6: All jumpers removed.

Use the following procedure to replace the SCSI disk drive assembly:

1. Place the mainframe chassis on the work surface so that the bottom side is facing up.
2. Insert the disk drive assembly into the chassis compartment and line up the mounting screw holes in the assembly plate with the screw holes in the chassis mainframe.
3. Install the six T-15 Torx screws that hold the assembly plate to the mainframe chassis. Tighten to 8 inch pounds of torque.
4. Connect the power supply cable to both hard disk drives.
5. Reroute the SCSI drive ribbon cable and connect the cable connectors to the hard disk drives. Dress the ribbon cable flat and clip the SCSI drive cable into the hold-down clips on the assembly plate.

---

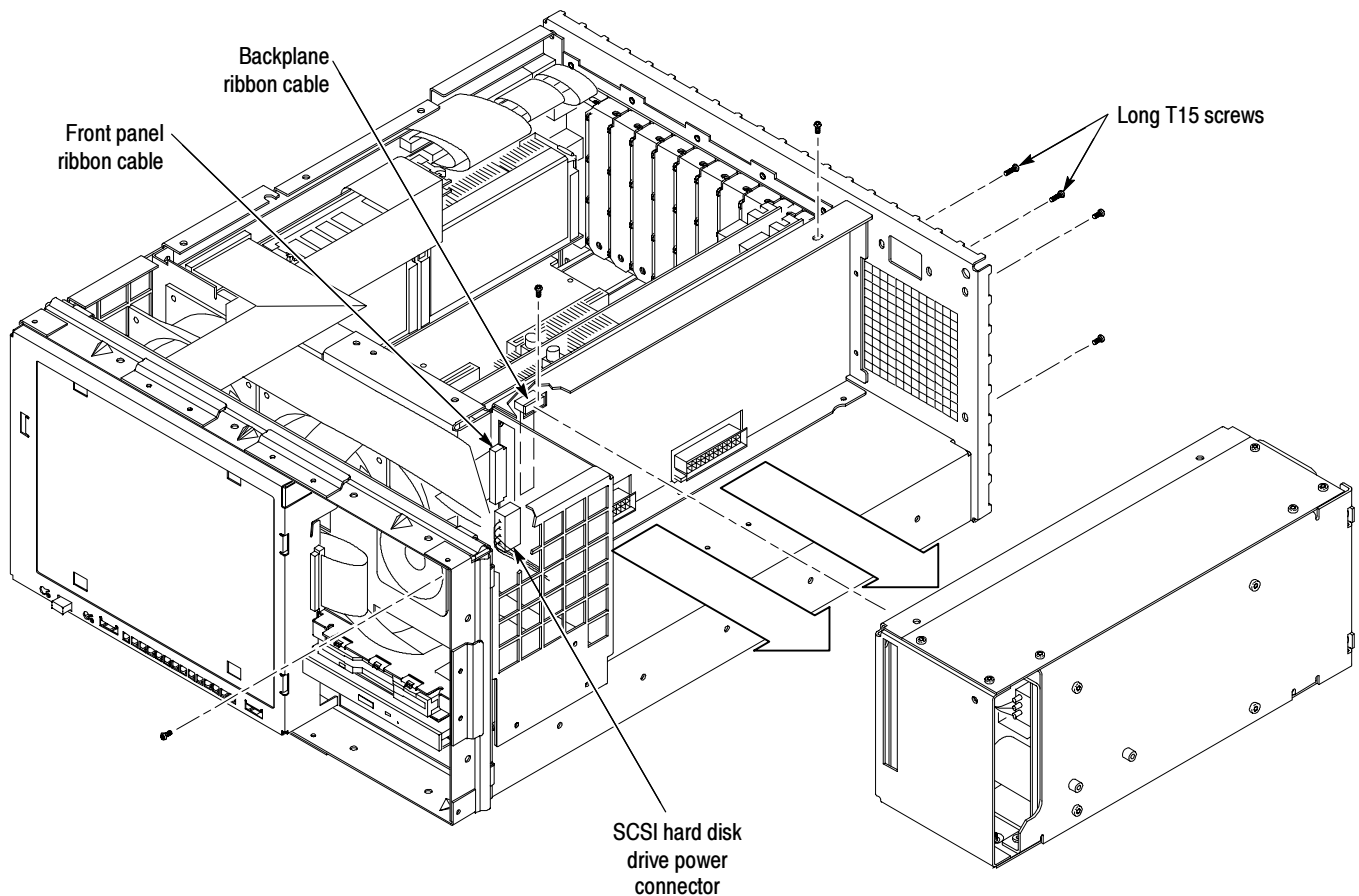
**NOTE.** *If you are replacing a hard disk drive, follow the instructions provided with the replacement disk drive to restore the software and disk partitioning required for the operating system.*

---

### **Power Supply Removal and Replacement**

Use the following steps to remove the power supply module:

1. Turn off and disconnect the main power from the PQA300.
2. Remove the measurement set cabinet (refer to *Removing the Cabinet* on page 6-5 for the removal instructions).
3. Remove the five short and two long T15 screws that attach the power supply module to the chassis (see Figure 6-13 for the screw locations).
  - a. At the front of the power supply module, remove one short T15 screw. Use a long shafted screwdriver to access the front screw through the hole in the chassis.
  - b. At the top of the power supply, remove two short T15 screws.
  - c. At the rear of the power supply, remove two short screws and two long T15 screws.



**Figure 6-13: Power supply large and small screws locations**

4. Disconnect the backplane ribbon cable from the power supply module connector.
5. Release the connector latches on the wide ribbon cable housing and disconnect the front panel ribbon cable from the front of the power supply module.
6. Disconnect the SCSI hard disk drive power cable from the front of the power supply module.
7. Slide the power supply module out of the chassis. Use a flat blade screwdriver as a lever if needed to disconnect the power supply connectors from the backplane connectors.

**Reinstall the Power Supply.** Use the following steps to reinstall the power supply module:

1. Align the power supply connectors with backplane connectors as shown in Figure 6-13.
2. Press the power supply module onto the backplane connectors/main chassis.
3. Attach the power supply module to the chassis with five short and two long T15 screws. Torque the screws to 8 in-lbs.
  - a. At the front of the power supply module, attach the power supply to the chassis with one short T15 screw.
  - b. Attach the top of the power supply to the chassis with two short T15 screws.

---

**NOTE.** *The long T15 screws are used for attaching the power supply to the chassis at either side of the line filter opening.*

---

- c. At the rear of the power supply, attach the power supply to the chassis with two short screws and two long T15 screws.
4. Plug in the backplane ribbon cable on the side of the power supply.
5. Plug the wide ribbon cable onto the power supply module connector on the front of the power supply.



---

**CAUTION.** *The power supply ribbon cable connector is difficult to fully plug on. Make sure both retaining latches are fully closed over the connector housing.*

---

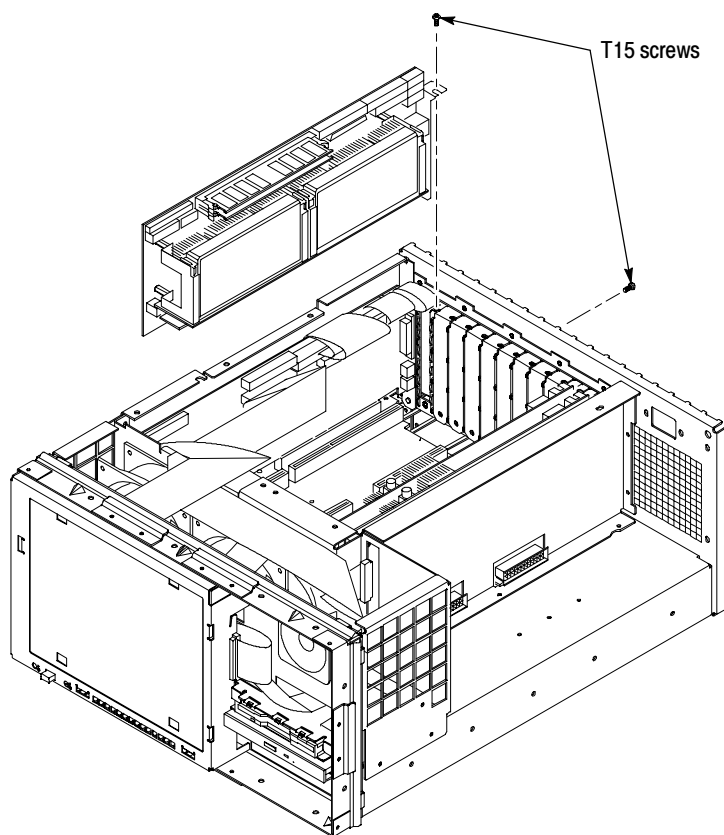
6. Plug the SCSI power cable onto the power supply connector located beneath the large ribbon cable connector on the front of the power supply chassis.

### **Controller Board Removal and Replacement**

Use the following procedure to remove the controller board.

1. Remove the circuit board retaining plate (see Figure 6-3 on page 6-8).
2. Remove the two T15 screws that hold the controller board to mainframe chassis (see Figure 6-14 for the screw locations).

3. Disconnect the SCSI disk drive ribbon cable from the controller board (see Figure 6-19).



**Figure 6-14: Controller board orientation and screw locations**

4. Disconnect the two 10-pin connectors (from J290 and J190 on the I/O circuit board) from the controller board.
5. Disconnect the 26-pin connector (from J170 on the I/O circuit board) from the bottom 26-pin connector on the controller board.
6. If the local display option is installed, disconnect the ribbon cable from the J4 connector on the controller board.
7. Carefully pull up on the controller board to loosen it from the backplane connectors.
8. When the board is loose from the backplane connectors, lift the assembly up and out of the module bay. Place the removed circuit board on a static-free surface or in a protective anti-static bag.

**Reinstall the Controller Board.** Use the following procedure to reinstall the controller circuit board. Refer to *CPU Jumper Settings* on page 6-37 to verify the correct positions of all the jumpers on the Controller board.

1. Position the controller board in the card bay in slot 11, the second slot from the right (when looking at the rear of the mainframe chassis).




---

**CAUTION.** While handling and installing the controller board, do not press on the memory SIMMs (single inline memory modules).

---

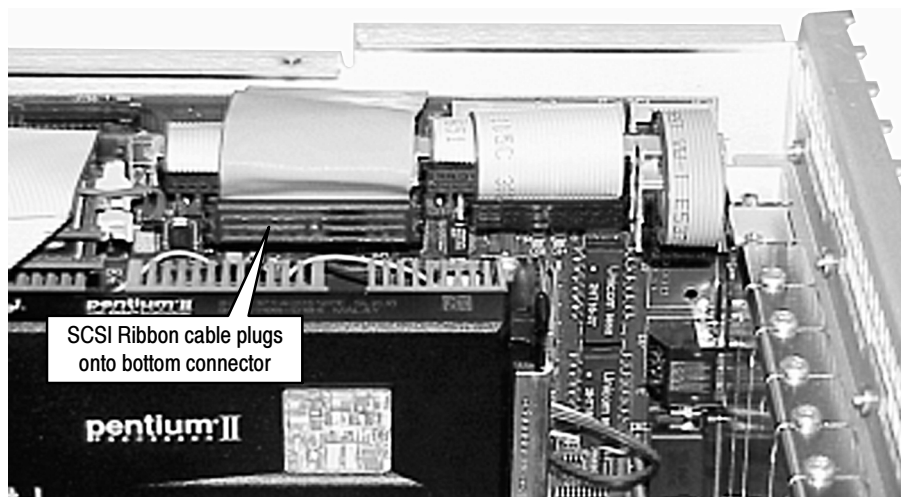
2. Lower the controller board into the mainframe while dressing the I/O board to controller board wiring harnesses away from the slot position.
3. Align the controller board edge connectors with the backplane slot connectors and press down firmly on the top edge of the circuit board to seat the controller board in the backplane connectors.
4. Attach the controller board bracket to the mainframe chassis with two T15 screws. Torque the screws to 8 in-lbs.
5. Reconnect the I/O board to controller board cables. Refer to *Connect I/O board to Controller board* on page 6-29 for the connection sequence.

### Controller I/O Board Removal and Replacement

The Controller I/O board has many interconnection cables to the controller board that must be disconnected for removal. After removing the cabinet and circuit board retaining plate, use the following procedure to remove the I/O circuit board:

1. Remove the two T15 screws that hold the controller I/O board to mainframe chassis (one on top and the other in the rear panel).
2. Disconnect the SCSI disk drive ribbon cable from the controller board (see Figure 6-15 for location).
3. Disconnect the two 10-pin connectors (from J290 and J190 on the I/O circuit board) from the controller board.
4. Disconnect the 26-pin connector (from J170 on the I/O circuit board) from the bottom 26-pin connector on the controller board.
5. If the local display option is installed, disconnect the ribbon cable from the LCD IN connector on the I/O board.
6. Carefully pull up on the I/O board to loosen it from the backplane connectors.
7. When the board is loose from the backplane connectors, lift the assembly up to gain access to the remaining interconnection cables.



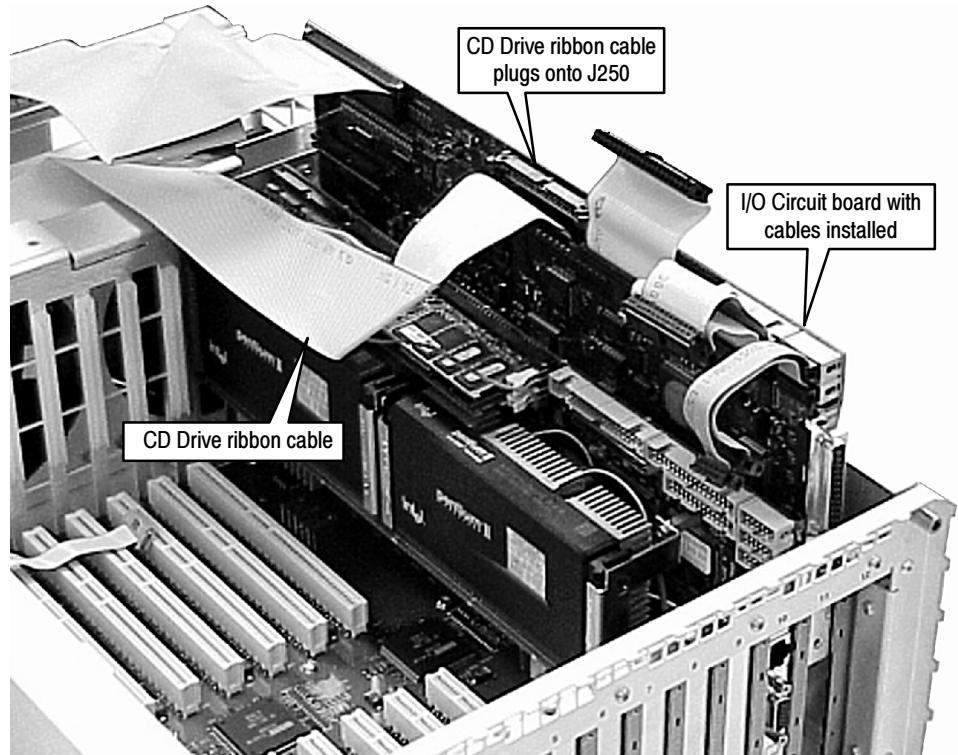


**Figure 6-15: SCSI ribbon cable connection location**

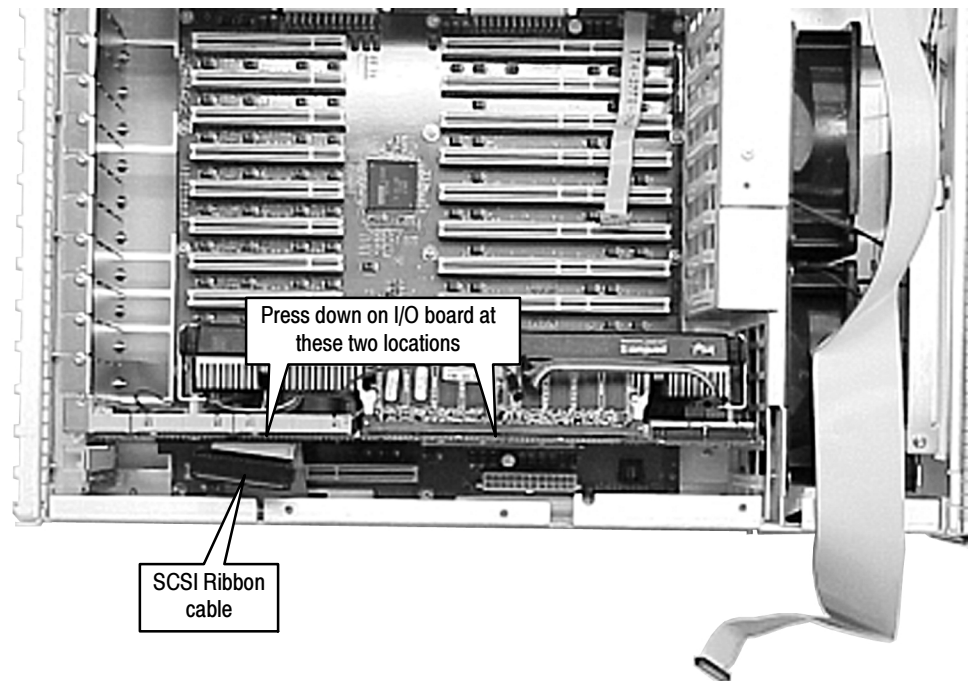
8. Disconnect the CD drive ribbon cable from J250 of the I/O circuit board.

**Reinstall the I/O Board.** Use the following steps to insert the I/O circuit board into the slot 12 position in the mainframe card bay:

1. Dress both controller board wire harnesses so that you can insert the I/O circuit board into the first slot as shown in Figure 6-16.
2. Hold the SCSI ribbon cable against the side of the mainframe and insert the I/O board into the slot. Align the front end of the circuit board with the guide rail on the front of the card bay.
3. Lower the I/O board into the mainframe slot but do not press the board into the backplane connector.
4. Route the CD drive ribbon cable over the I/O board.
5. Lift up the I/O board and (with one hand bracing the circuit board on the backside) plug the CD drive ribbon cable onto J250 of the I/O board.
6. Place your fingers on the top of the I/O board at the locations indicated in Figure 6-17 (directly over the J11 backplane connector) and press down to seat the board into the backplane connector.



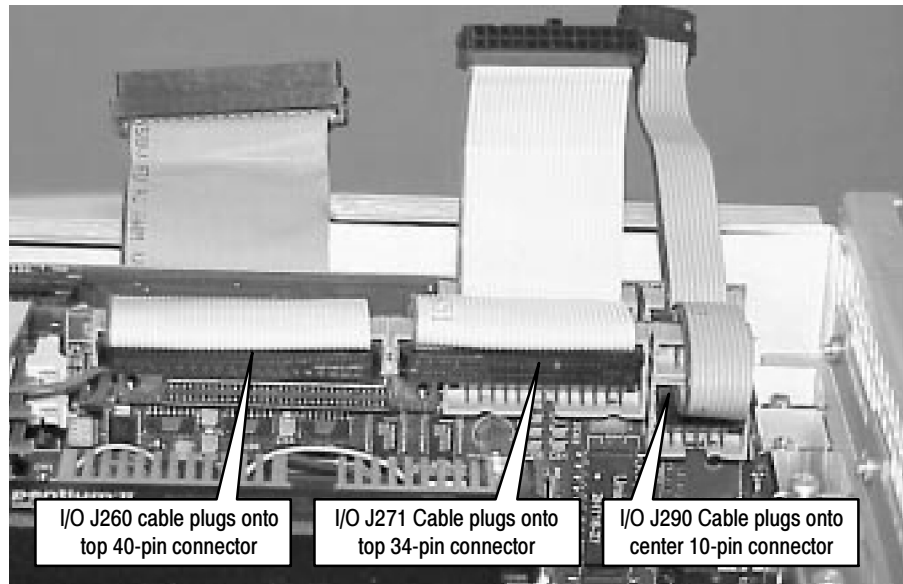
**Figure 6-16: Insert I/O board into slot 12**



**Figure 6-17: Installing the I/O circuit board**

**Connect I/O board to Controller board.** The interconnection cables between the I/O board and the controller board have to be connected in sequence that permits all the cables to be attached. Use the following step to make the cable connections.

1. Plug the ribbon cable from J290 of the I/O board to the center 10-pin connector on the controller board as shown in Figure 6-18.
2. Plug the ribbon cable from J271 of the I/O board to the top 34-pin connector of the controller board.



**Figure 6- 18: I/O to controller board top interconnections**

3. Plug the ribbon cable from J260 of the I/O board to the top 40-pin connector of the controller board.
4. Plug the ribbon cable from J190 of the I/O board to the bottom 10-pin connector as shown in Figure 6-19.
5. Plug the ribbon cable from J170 of the I/O board to the bottom 26-pin connector.
6. Plug the SCSI ribbon cable to the controller board bottom connector.
7. If the local display option is installed, connect the flat ribbon cable from J4 on the controller board to the LCD IN connector on the I/O board.

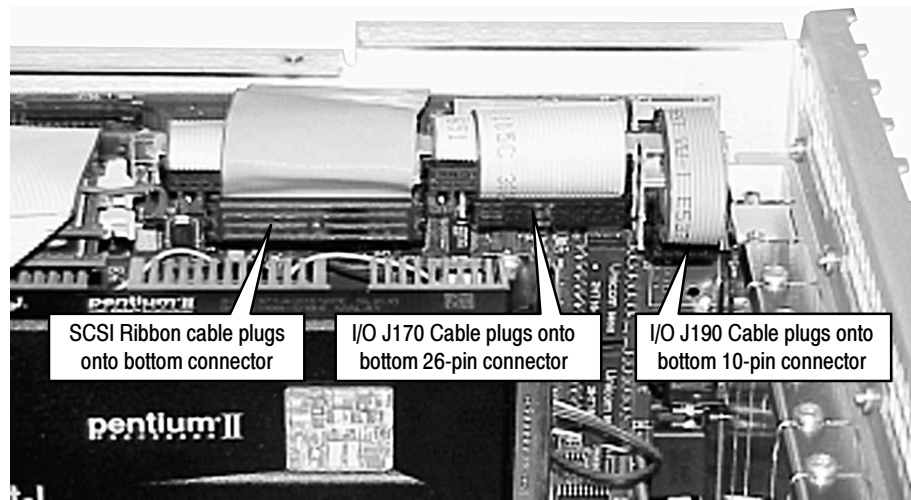


Figure 6-19: I/O to controller board bottom interconnections

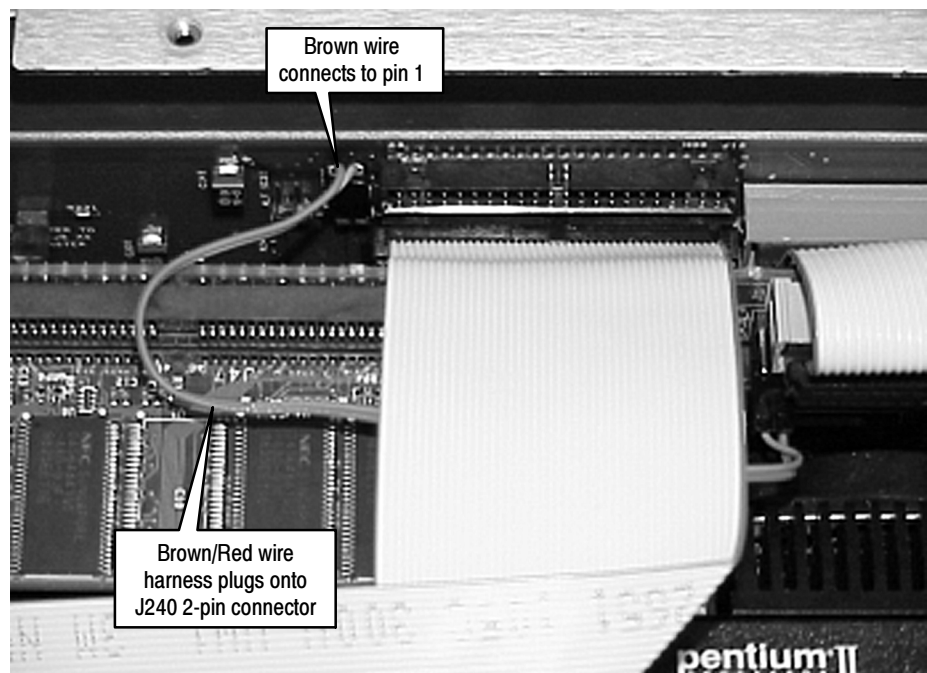
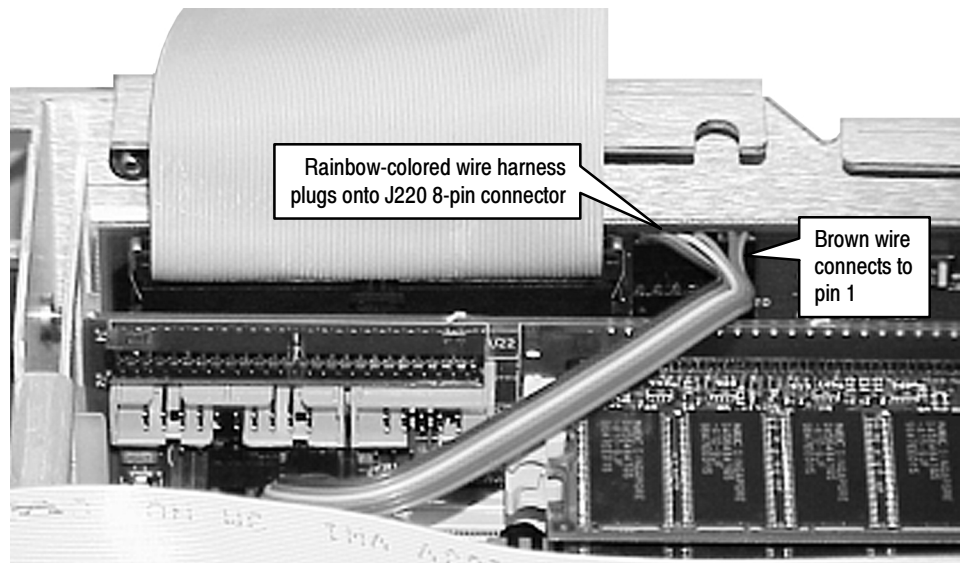


Figure 6-20: Top connection to controller board

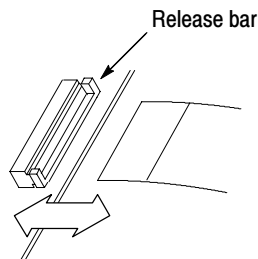


**Figure 6-21: Location of J220 connections and wiring orientation**

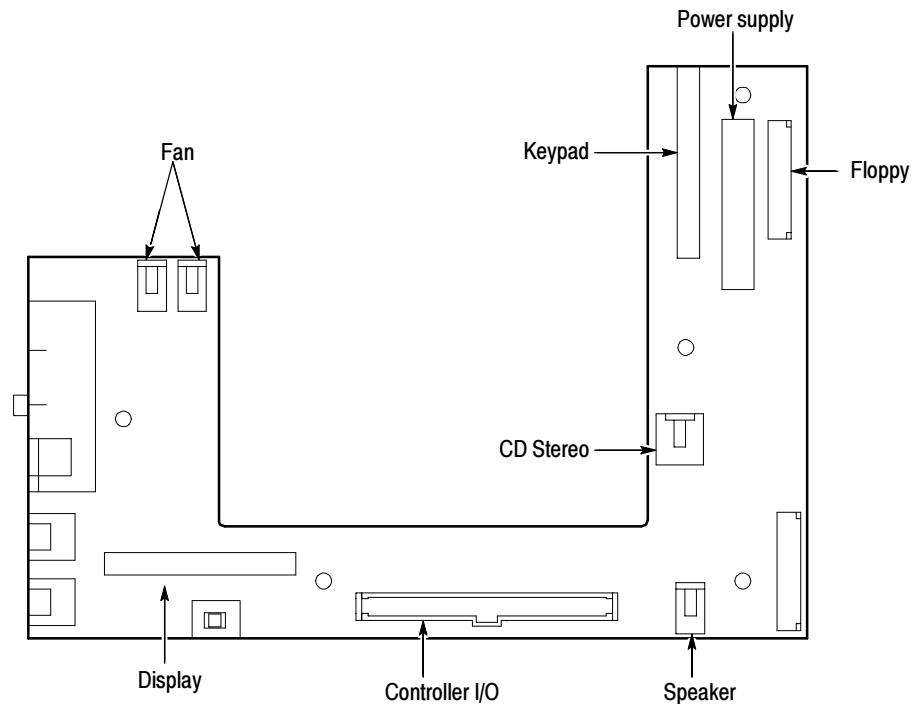
### **Interface Board Removal and Replacement**

Use the following procedure to remove the interface board:

1. Disconnect the speaker wire from the interface board J980 connector, see Figure 6-22.
2. Disconnect the right side fan wire from the interface board J420 (right FAN) connector.
3. Disconnect the left side fan wire from the interface board J410 (left FAN) connector.
4. Disconnect the floppy disk drive flexible circuit board from the interface board disk drive connector.
  - a. Release the locking latch on the flexible circuit board connector.



- b. Pull the flexible circuit board straight out of the connector.

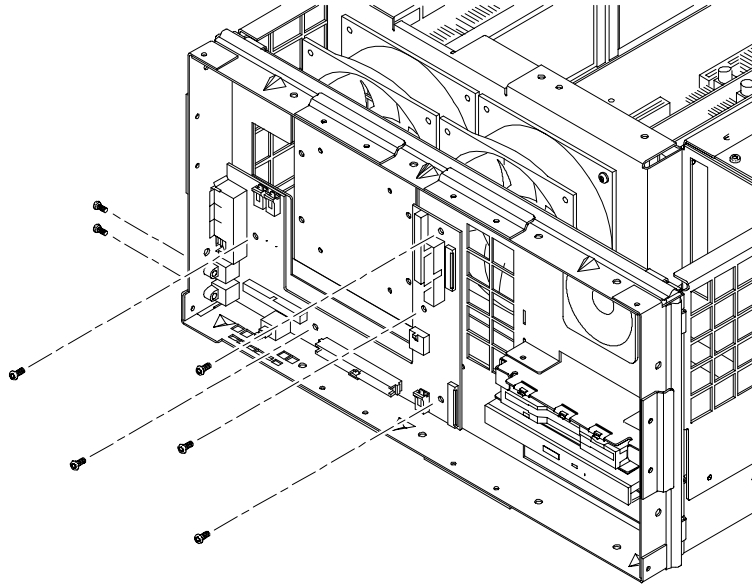


**Figure 6-22: Front panel interface circuit board connectors**

5. Disconnect the CD audio cable.
6. Disconnect the controller I/O ribbon cable from the interface board.
7. Disconnect the power supply cable.
8. Disconnect the keypad assembly ribbon cable from the interface board.
9. Remove the five T15 screws from the front of the board and the two metric screws on the left side that attach the interface board to the chassis (see Figure 6-23 for the screw locations).

**Reinstall the Interface Board.** Install the interface board onto the mainframe chassis as shown in Figure 6-23.

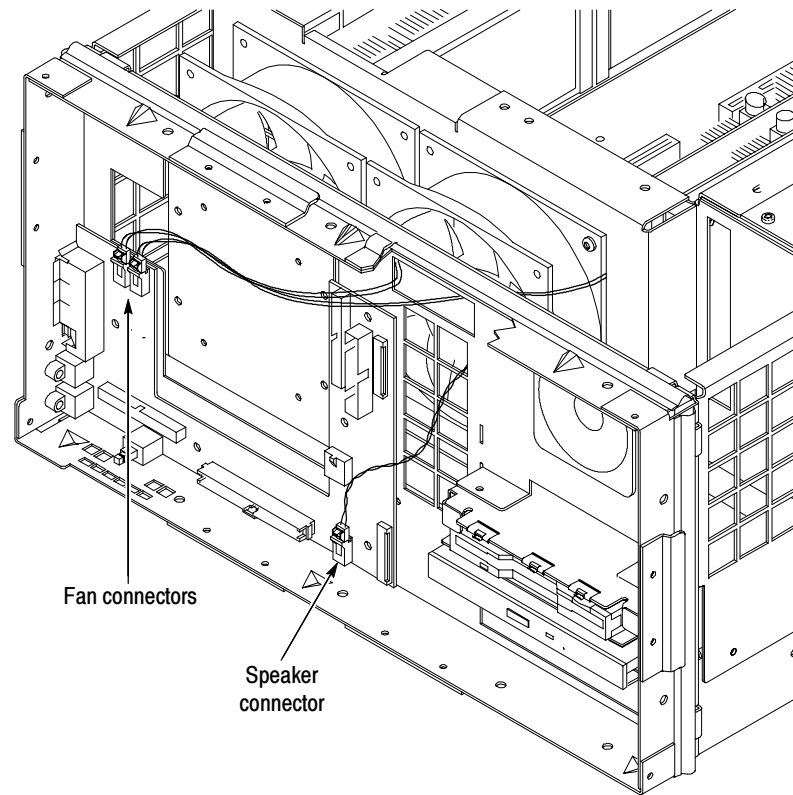
1. Orient the interface board so that the board components are facing up and the mouse/keyboard connectors are to the left.
2. Align the interface board mounting holes with the chassis studs and place the board onto chassis.



**Figure 6-23: Screw locations for the interface circuit board**

3. Attach the interface board to the chassis with five T15 screws through the front of the board and two metric screws at the side connectors. Torque the T15 screws to 8 in-lbs. Torque the metric screws to 2 in-lbs.
4. Route both fan wire harnesses through the slot in the chassis as shown in Figure 6-24.
5. Plug the left side fan wire harness into the interface board J410 (left FAN) connector as shown in Figure 6-24.
6. Plug the right side fan wire harness into the interface board J420 (right FAN) connector as shown in Figure 6-24.
7. Route the speaker wire harness through the top/right chassis ventilation hole as shown in Figure 6-24.
8. Plug the speaker wire harness into the interface board J980 connector as shown in Figure 6-24.
9. Connect the disk drive flexible circuit board to the interface board disk drive connector.





**Figure 6-24: Cut-away view showing wire routing of fan and speaker wires**

- 10.** Connect the ribbon cable connector from the controller I/O to the interface board controller connector.
- 11.** Connect the CD stereo cable.
- 12.** Connect the power supply cable.
- 13.** Connect the ribbon cable connector from the keypad assembly to the interface board.
- 14.** Reinstall the interface circuit board cover assembly.

## **Backplane Circuit Board Removal and Replacement**

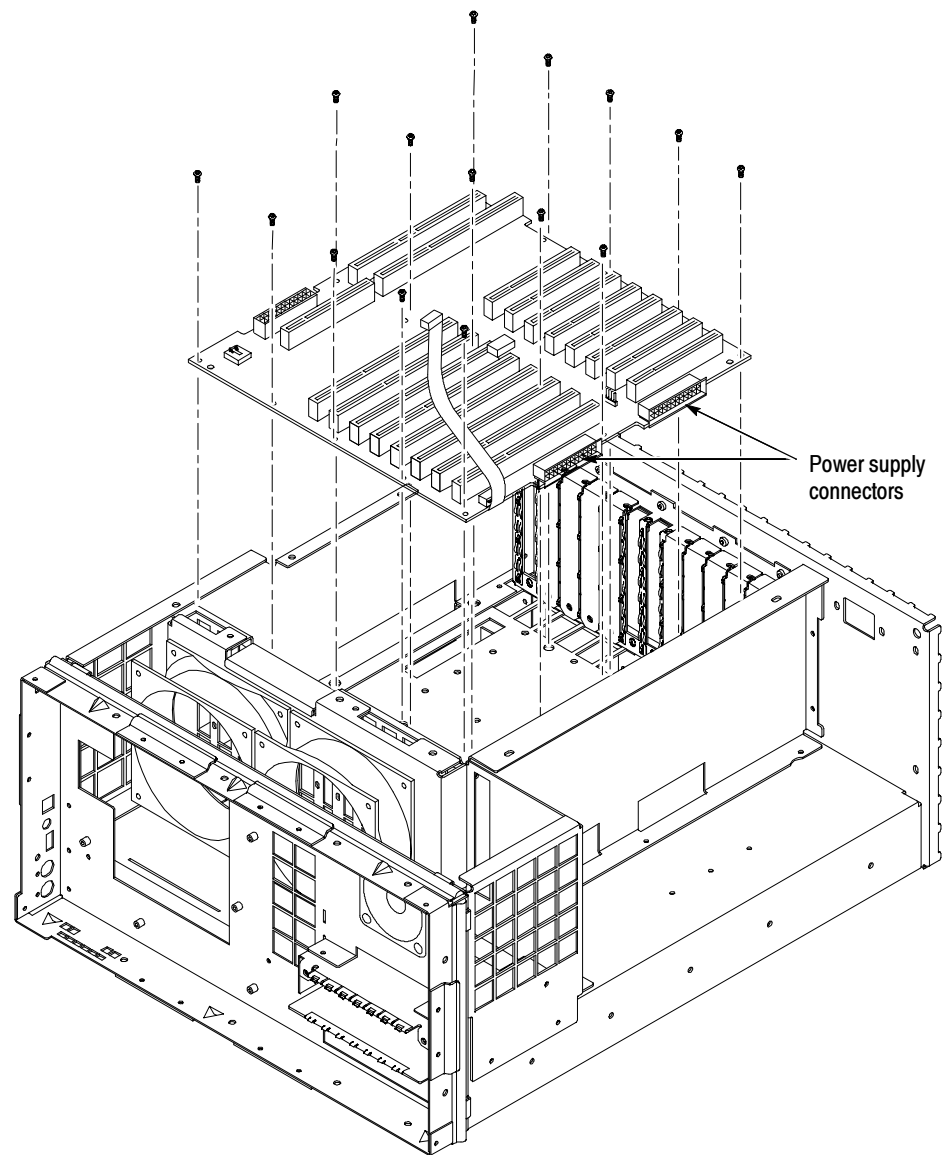
To remove the backplane, you must first remove the power supply and all of the plug-in modules.

**Remove the Backplane.** With the cabinet off the chassis, use the following procedure to remove the backplane:

1. Remove the power supply module (see *Power Supply Removal and Replacement* on page 6-22).
2. Remove all of the plug-in modules from the card bay (see the PQA300 module removal instructions starting with *Removing a Plug-in Module* on page 6-8).
3. Disconnect the RS232 cable connector from the backplane circuit board.
4. Remove the 15 screws holding the backplane board assembly to the chassis with a T15 screw tip screwdriver (see Figure 6-25 for the screw locations).
5. Lift the back plane board assembly out of the chassis.

**Reinstall the Backplane.** Use the following procedure to reinstall the backplane circuit board into the mainframe card bay.

1. Place the backplane board assembly into the mainframe chassis. See Figure 6-25 for orientation of back plane to chassis.
2. Attach backplane board assembly to the chassis with fifteen T15 screws. Torque the screws to 8 in-lbs.
3. Connect the RS232 cable connector to the backplane circuit board.
4. Reinstall the PCI plug in modules using their reinstallation instructions (refer to *Reinstalling a Plug-In Module* on page 6-9 and *Controller I/O Board Removal and Replacement* on page 6-26).
5. Reinstall the power supply assembly using its reinstallation instructions (refer to *Power Supply Removal and Replacement* on page 6-22).
6. Reinstall the circuit board retaining plate.
7. Reinstall the cabinet and front bezel to complete the assembly (refer to *Replacing the PQA300 Cabinet* on page 6-6 and *Replacing the Bezel Trim Ring* on page 6-7).



**Figure 6-25: Backplane orientation and screw locations**

### **CPU Jumper Settings**

Jumper positions set the CPU clock speed, enable or disable CPU features, or make operational settings for the CPU. The following tables show the jumper settings. Figure 6-26 shows the jumper locations on the CPU board with the jumpers in their factory settings.

**CPU and Bus Speed Settings.** The CPU speed setting is 266 MHz with a bus speed of 66 MHz.

**Table 6-2: CPU Speed settings**

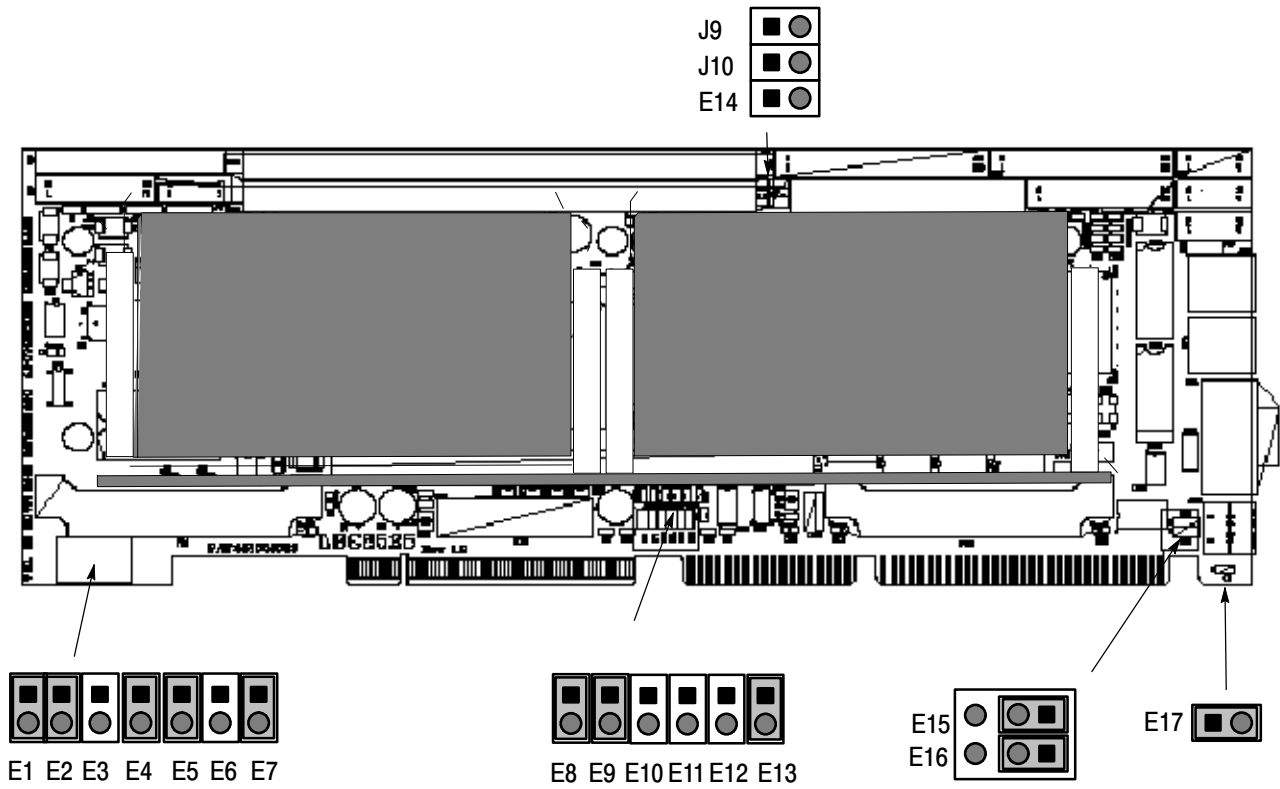
<b>CPU Speed</b>	<b>Bus</b>	<b>E1</b>	<b>E2</b>	<b>E3</b>	<b>E4</b>
233 MHz	66 MHz	OFF	OFF	ON	ON
266 MHz	66 MHz	ON	ON	OFF	ON
300 MHz	66 MHz	OFF	ON	OFF	ON
333 MHz	66 MHz	ON	OFF	OFF	ON
350 MHz	100 MHz	OFF	OFF	ON	ON
400 MHz	100 MHz	ON	ON	OFF	ON
450 MHz	100 MHz	OFF	ON	OFF	ON

**VGA Display Settings.** The VGA display jumpers on the CPU board are set for the default LCD flat panel display provided with Option LC. This is an 800 X 600 LCD display only. To use a 1024 X 768 TFT flat panel display, you need to change the jumper at E10 to “short.” If you attempt to use a DSTN flat panel at 1024 X 768, the four jumpers at E10, E11, E12, and E13 must all be on or in the “short” position.

**Table 6-3: Flat panel jumper settings**

<b>VGA Display</b>	<b>E10</b>	<b>E11</b>	<b>E12</b>	<b>E13</b>
640 X 480 TFT (Sharp)	OFF	ON	OFF	ON
800 X 600 TFT	OFF <sup>1</sup>	OFF <sup>1</sup>	OFF <sup>1</sup>	ON <sup>1</sup>
1024 X 768 TFT	ON	OFF	OFF	ON
1280 X 1020 TFT	OFF	ON	ON	ON
640 X 480 DSTN	ON	OFF	ON	ON
800 X 600 DSTN	OFF	OFF	ON	ON
1024 X 768 DSTN	ON	ON	ON	ON

<sup>1</sup> Default setting for the PQA3FLC flat panel display



**Figure 6-26: CPU Jumper setting locations**

## Repacking for Shipment

Before shipping an instrument to a Tektronix field office for repair, attach a tag to the instrument showing the following:

- Owner's name and address
- Serial number
- Description of the problem(s) encountered and/or service required.

The PQA300 Picture Quality Analysis System is shipped in cartons designed to provide it with the maximum protection. If you ship the instrument subsequently, you will need to use these cartons, the spacer pads, the protective bag, and the instrument support inserts to provide adequate protection.

---

**NOTE.** *The PQA300 Picture Quality Analysis System shipping carton in good condition must be used to return the instrument to Tektronix service centers. We cannot honor the warranties if the PQA300 is not shipped in its original carton or in a replacement carton and its supporting packaging material purchased from Tektronix. Contact your Tektronix representative to obtain new packaging.*

---

## Obtaining Replacement Packaging

New packaging material is available from Tektronix. The part numbers are in Table 6-4 and in the *Replaceable Mechanical Parts List* in the service manual. Packaging components are shown in Figure 6-28. Each component has an index number, which also appears in Table 6-4. To obtain these items contact your nearest Tektronix office or representative.

**Table 6-4: Packaging material**

Item	Tektronix part number	Index number
Accessory tray (keyboard)	004-4851-00	
Accessory tray	004-4852-00	
Spacer pad (makes two pads for inner shipping box)	004-4925-01	
Anti-static pouch	006-2427-01	
Protective bag	006-8164-00	
Top tray (cardboard insert)	004-4912-00	1
Instrument support inserts; top and bottom	004-4913-00	2

**Table 6-4: Packaging material (Cont.)**

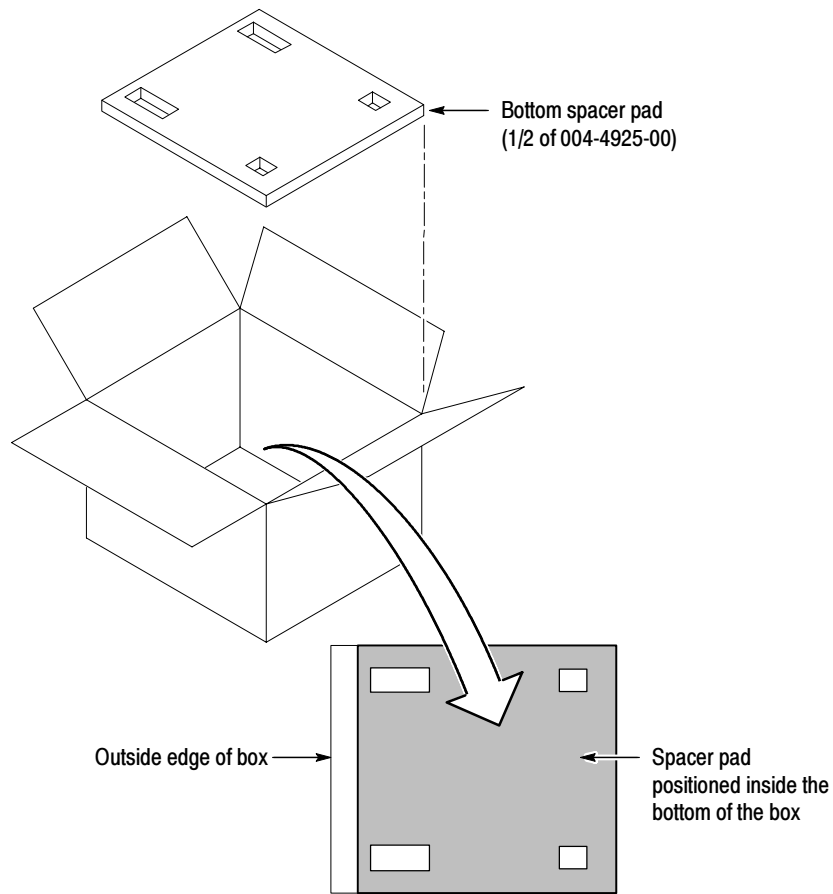
Item	Tektronix part number	Index number
Inner shipping box	004-4926-00	3
Shipping box	004-4914-00	4

## Repackaging Instructions

When the PQA300 is shipped, it is important to provide it with the maximum protection. Figure 6-27 shows how to repack the PQA300 for shipment. As the figure shows, it is not necessary to send the accessories with the PQA300 for reshipment to repair. If you are shipping to another site for reinstallation, pack the accessories last, in accessory trays at the top of the box.

The inner shipping box, pads, and protective bag provide the necessary protection to allow the shipping materials of the outer shipping box to correctly support the product for shipment. Pack the inner shipping box as follows:

1. If you have the original packaging material, start by placing one of the spacer pads in the bottom of the inner box. Position the side of the pad with the smaller, square holes against the side of the box as shown in Figure 6-27.
2. Remove the optional accessory pouch, if installed, and place the protective front cover on the front of the PQA300.
3. Place the PQA300 in the protective bag. The bag prevents dust, moisture, or other small packaging debris from entering the cabinet.
4. Fold the top of the bag neatly over the top of the PQA300 to make it as flat as possible and seal with packing tape.
5. Place the bagged PQA300 in the inner shipping box. The small feet on the bottom of the cabinet go in the square holes in the spacing pad and the larger feet near the front of the PQA300 go in the larger rectangular holes. The bezel end of the cabinet fits over the edge of the spacer pad.



**Figure 6-27: Placement of bottom spacer pad in inner shipping box**

6. Place the other spacer pad on top of the PQA300. Again, place the side with the small square holes against the side of the box. The protective front cover on the bezel of the PQA300 is not covered by the top spacer pad.
7. Close and tape the inner shipping box.
8. Place one of the support inserts in the bottom of the outer shipping box, film side up as shown in Figure 6-28.
9. Place the sealed inner shipping box in the center of the bottom support insert in the outer shipping box.
10. Put the second support insert over the inner shipping box, film side down.

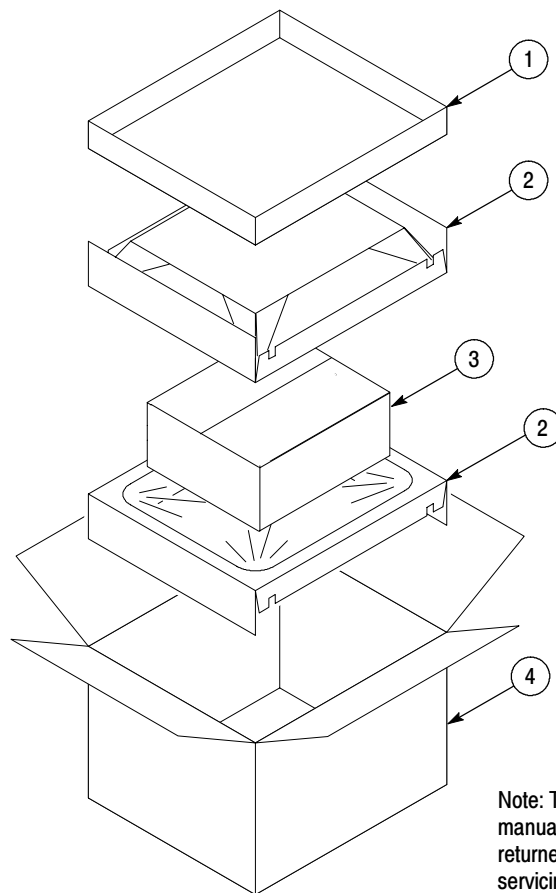


---

**NOTE.** *If you are using new packing material purchased from Tektronix, pre-stretch the film in the support inserts by pushing down firmly several times on the top support insert.*

---

11. Place the top tray in the box. If you are not shipping accessories with the PQA300 system, close and tape the outer shipping box.
12. When shipping the accessories, place the two accessory trays in the top tray, arrange the accessories in the trays, and then close and tape the outer shipping box.
13. Attach the appropriate shipping documents needed to ship the PQA300 system to its destination (either to Tektronix for repair or to another location).



**Figure 6-28: Repackaging**





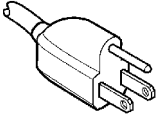
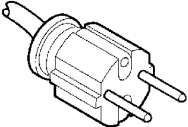
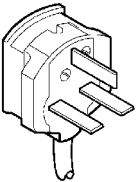
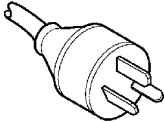
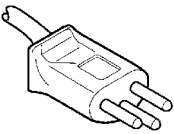
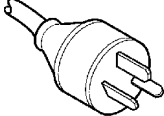
# Options



# Options

The power cord options shown in Table 7-1 are available for the PQA300 Picture Quality Analysis System.

**Table 7-1: Power Cord Options**

Plug configuration	Nominal usage	Option number	Tektronix part number
	North America 125 V/15 A	Standard	161-0216-00
	Europe 230 V/16 A	A1	161-0066-09
	United Kingdom 230 V/15 A	A2	161-0066-10
	Australia 230 V/10 A	A3	161-0066-11
	Switzerland 230 V/10 A	A5	161-0154-00
	China 240 V/10 A	AC	161-0304-00

## **Option 01 Composite Video**

The composite video option adds an encoder module for use in generating NTSC or PAL composite video and S-Video PQA200 test video sequences. The encoder module accepts 601 digital video from the generator DSP and performs the encoding to composite video. A decoder module is used with the analyzer DSP to capture NTSC and PAL composite video or S-Video. Composite video signals are converted to 601 digital video for application to the analyzer DSP for processing.

## **Option LC Display**

The Option LC provides an integrated display, touch screen, U.S. keyboard, keypad, and three-button mouse.



# **Replaceable Parts**





# Replaceable Parts

This section contains a list of the replaceable modules. Use this list to identify and order replacement parts.

## Parts Ordering Information

Replacement parts are available through your local Tektronix field office or representative.

Changes to Tektronix products are sometimes made to accommodate improved components as they become available and to give you the benefit of the latest improvements. Therefore, when ordering parts, it is important to include the following information in your order:

- Part number
- Instrument type or model number
- Instrument serial number
- Instrument modification number, if applicable

If you order a part that has been replaced with a different or improved part, your local Tektronix field office or representative will contact you concerning any change in part number.

### Module Servicing

Modules can be serviced by selecting one of the following three options. Contact your local Tektronix service center or representative for repair assistance.

**Module Exchange.** In some cases you may exchange your module for a remanufactured module. These modules cost significantly less than new modules and meet the same factory specifications. For more information about the module exchange program, call 1-800-833-9200. Outside North America, contact a Tektronix sales office or distributor; see the Tektronix web site for a list of offices: [www.tektronix.com](http://www.tektronix.com).

**Module Repair and Return.** You may ship your module to us for repair, after which we will return it to you.

**New Modules.** You may purchase replacement modules in the same way as other replacement parts.

## Using the Replaceable Parts List

This section contains a list of the mechanical and/or electrical components that are replaceable for the PQA300 Picture Quality Analysis System. Use this list to identify and order replacement parts. The following table describes each column in the parts list.

### Parts List Column Descriptions

Column	Column name	Description
1	Figure & Index Number	Items in this section are referenced by figure and index numbers to the exploded view illustrations that follow.
2	Tektronix Part Number	Use this part number when ordering replacement parts from Tektronix.
3 and 4	Serial Number	Column three indicates the serial number at which the part was first effective. Column four indicates the serial number at which the part was discontinued. No entries indicates the part is good for all serial numbers.
5	Qty	This indicates the quantity of parts used.
6	Name & Description	An item name is separated from the description by a colon (:). Because of space limitations, an item name may sometimes appear as incomplete. Use the U.S. Federal Catalog handbook H6-1 for further item name identification.
7	Mfr. Code	This indicates the code of the actual manufacturer of the part.
8	Mfr. Part Number	This indicates the actual manufacturer's or vendor's part number.

**Abbreviations**      Abbreviations conform to American National Standard ANSI Y1.1-1972.

**Mfr. Code to Manufacturer Cross Index**      The table titled Manufacturers Cross Index shows codes, names, and addresses of manufacturers or vendors of components listed in the parts list.

### Manufacturers cross index

Mfr. code	Manufacturer	Address	City, state, zip code
00779	AMP INC.	CUSTOMER SERVICE DEPT PO BOX 3608	HARRISBURG, PA 17105-3608
060D9	UNITREK CORPORATION	3000 COLUMBIA HOUSE BLVD, SUITE 1 20	VANCOUVER, WA 98661
06383	PANDUIT CORP	17303 RIDGELAND AVE	TINLEY PARK, IL 60477-3048
06915	RICHCO	5825 N TRIPP AVE P.O. BOX 804238	CHICAGO, IL 60646
01963	CHERRY ELECTRICAL PRODUCTS CO	3600 SUNSET AVENUE	WAUKEGAN, IL 60087-3214
03ZT7	MOBILE PLANET	9175 DEERING AVE	CHATSWORTH, CA 91311
060D9	UNITREK CORPORATION	3000 COLUMBIA HOUSE BLVD, SUITE 1 20	VANCOUVER, WA 98661
0ADN8	DELTA PRODUCTS CORP-DPZ	4405 CUSHING PARKWAY	FREMONT, CA 94538

## Manufacturers cross index (Cont.)

<b>Mfr. code</b>	<b>Manufacturer</b>	<b>Address</b>	<b>City, state, zip code</b>
0B445	ELECTRI-CORD MFG CO INC	312 EAST MAIN STREET	WESTFIELD, PA 16950
0D1M6	NMB TECHNOLOGIES INC	9730 INDEPENDENCE AVE	CHATSWORTH, CA 91311
0KB01	STAUFFER SUPPLY CO	810 SE SHERMAN	PORTLAND, OR 97214-4657
0KB05	NORTH STAR NAMEPLATE INC	5750 NE MOORE COURT	HILLSBORO, OR 97124-6474
12136	PHC INDUSTRIES INC	1643 HADDON AVE PO BOX 1448	CAMDEN, NJ 08103
1AW87	LEWIS SCREW CO.	4300 SOUTH RACINE AVENUE	CHICAGO, IL 60609
22670	GM NAMEPLATE INCORPORATED	2040 15TH AVE WEST	SEATTLE, WA 98119-2783
26233	NYLOK FASTENER CORP	1161 E SANDHILL AVE #D PO BOX 5228	CARSON, CA 90746
2K262	BOYD CORPORATION	6136 NE 87TH AVENUE	PORTLAND, OR 97220
2W733	BELDEN WIRE & CABLE COMPANY	2200 US HWY 27 SOUTH PO BOX 1980	RICHMOND, IN 47374
30817	INSTRUMENT SPECIALTIES CO INC.	SHIELDING WAY PO BOX 650	DELAWARE WATER GAP, PA 18327
3M099	PORTLAND SCREW COMPANY	6520 N BASIN AVE	PORTLAND, OR 97217
46628	LOGITECH INC	6505 KAISER DR	FREMONT, CA 94555
4T165	NEC ELECTRONICS, INC.	2880 SCOTT BLVD PO BOX 58062	SANTA CLARA, CA 95052-8062
50356	TEAC AMERICA INC	7733 TELEGRAPH RD PO BOX 750	MONTEBELLO, CA 90640-6537
52152	3M COMPANY	INDUSTRIAL TAPE DIVISION 3M CENTER	ST PAUL, MN 55144-1000
54407	POWER-ONE INC	740 CALLE PLANO	CAMARILLO, CA 93010
5F520	PANEL COMPONENTS CORP	PO BOX 115	OSKALOOSA, IA 52577-0115
5Y400	TRIAx METAL PRODUCTS INC	1880 SW MERLO DRIVE	BEAVERTON, OR 97006
61058	MATSUSHITA ELECTRIC CORP OF AMERICA	PANASONIC INDUSTRIAL CO DIV TWO PANASONIC WAY	SECAUCUS, NJ 07094
64409	DIVERSIFIED TECHNOLOGY INC	476 HIGHLAND COLONY PKY PO BOX 748	RIDGELAND, MS 39158-0748
7X318	KASO PLASTICS INC	5720-C NE 121ST AVE, STE 110	VANCOUVER, WA 98682
80009	TEKTRONIX INC	14150 SW KARL BRAUN DR PO BOX 500	BEAVERTON, OR 97077-0001
80126	PACIFIC ELECTRICORD CO	747 WEST REDONDO BEACH PO BOX 10	GARDENA, CA 90247-4203
8Z692	INTERMEC TECHNOLOGIES CORP	9290 LESAINTE DRIVE	FAIRFIELD, OH 45014
93907	CAMCAR DIV OF TEXTRON INC	ATTN: ALICIA SANFORD 516 18TH AVE	ROCKFORD, IL 611045181
9F560	IBM CORPORATION	420 E SOUTH TEMPLE ST	SALT LAKE CITY, UT 84145
TK0AT	AMP, INC	7-15-14 ROPPONGI MINATO-KU	TOKYO JAPAN,
TK0588	UNIVERSAL PRECISION PRODUCT	1775 NW CORNELIUS PASS RD	HILLSBORO, OR 97124
TK1163	POLYCAST INC	14140 SW 72ND AVE SUITE 100	TIGARD, OR 97224
TK1562	XPEDX.	9111 NE COLUMBIA BLVD	PORTLAND, OR 97220
TK1935	ACCRA-FAB INC	11007 NE 37TH CIRCLE	VANCOUVER, WA 98682

**Manufacturers cross index (Cont.)**

<b>Mfr. code</b>	<b>Manufacturer</b>	<b>Address</b>	<b>City, state, zip code</b>
TK1943	NEILSEN MANUFACTURING INC	3501 PORTLAND RD NE	SALEM, OR 97303
TK2172	WYLE ELECTRONICS INC	10300 SW NIMBUS AVE BLDG P, SUITE B	PORTLAND, OR 97223
TK2250	ARROW ELECTRONICS INC.	9500 SW NIMBUS AVE, BLDG E	BEAVERTON, OR 97008-7163
TK2383	PANASONIC INDUSTRIAL CO	1600 MC CANDLESS DR	MILPITAS, CA 95035
TK2376	CONDUCTIVE RUBBER TECH	22125 17TH AVE SE, SUITE 117	BOTHELL, WA 98021
TK2383	PANASONIC INDUSTRIAL CO	1600 MC CANDLESS DR	MILPITAS, CA 95035
TK2385	METALCAST ENGINEERING INC	4800 COLISEUM WAY	OAKLAND, CA 94601
TK2411	TEKTRONIX HONG KONG	8/F MAPPIN HOUSE 98 TEXACO RD	TSUEN WAN, N. T., HONG KONG CN
TK2480	WILLAMETTE PLASTIC	1111 NW 5TH PLACE	CANBY, OR 97013
TK2541	AMERICOR ELECTRONICS LTD	UNIT-H 2682 W COYLE AVE	ELK GROVE VILLAGE, IL 60007
TK2548	XEROX CORPORATION	14181 SW MILLIKAN WAY	BEAVERTON, OR 97005
TK2607	VANSTAR CORPORATION	OREGON CORP ACCOUNTS DIVISION 16280 SW UPPER BOONES FERRY RD	PORTLAND, OR 97224
TK2647	INSTRUMENT SPECIALTIES CO INC.	C/O TEMCO NW 1336 SE 51ST STREET	HILLSBORO, OR 97123
TK6074	DYNAPRO THIN FILM PRODUCTS	7025 WEST MARCIA RD.	MILWAUKIE, WI 53223
TK6108	KENT H LANDSBERG CO	27929 SW 95TH, SUITE 101	WILSONVILLE, OR 97070
TK6181	IMC PLASTICS INC	19400 SW TETON AVE	TUALATIN, OR 97062

**Replaceable parts list**

Fig. & index number	Tektronix part number	Serial no. effective	Serial no. discont'd	Qty	Name & description	Mfr. code	Mfr. part number
8-1							
1	671-4778-00		B010122	1	CIRCUIT BD ASSY: PICMG BACKPLANE	80009	671-4778-00
	671-4778-01	B010123		1	CIRCUIT BD ASSY: PICMG BACKPLANE	80009	671-4778-01
2	211-0722-00				SCREW. MACHINE: 6-32 X 0.250. PNH. STL. CDPL. T-15 TORX DR	0KB01	ORDER BY DESCRIPTION
3	351-1022-00			10	CARD GUIDES: L-3.0(76.2) A-2.5(63.5). NYLON 6/6. RMS-48	06915	RN-300-2
4	441-2180-00			1	CHASSIS ASSY: AL. ETCH & CHROMATE.	TK1943	441-2180-00
5	011-0175-00			1	TERMINATOR: SCSI III. SINGLE ENDED. ACTIVE. SHIELDED. 68 POS. MALE. 0.05 CTR. W/JACK-SCREWS	TK0AT	869516-1
6	211-0722-00				SCREW. MACHINE: 6-32 X 0.250. PNH. STL. CDPL. T-15 TORX DR	0KB01	ORDER BY DESCRIPTION
7	119-5832-00			1	FILTER. RFI: LINE FILTER. 6A. 50/60 HZ. 115/260 VAC. LEAKAGE CURRENT 0.4MA AT 250VAC/60HZ. 06GENG	0ADN8	06GENG3E
8	378-0454-00			1	FAN GUARD: FAN. GUARD. 4-POSITION	0D1M6	055013
9	119-5694-00			1	FAN. DC: TUBEAXIAL. 12 V. 2.7W. 83 CFM. 56.8 DBA. 2850 RPM. 92MM X 92MM X 25MM. W/2 PIN CONNECT	61058	FBA09A12H
10	650-3760-01			1	PWR SUPPLY ASSY:	80009	650-3760-01
11	174-3795-00			1	CABLE ASSY. SP: SPEAKER. CPD. 30-26AWG. 10.0 L. 1X2. 0.1 CTR. RCPT. FEMALE. LATCHING. PLZ. MTE. AMP 103961-	060D9	174-3795-00

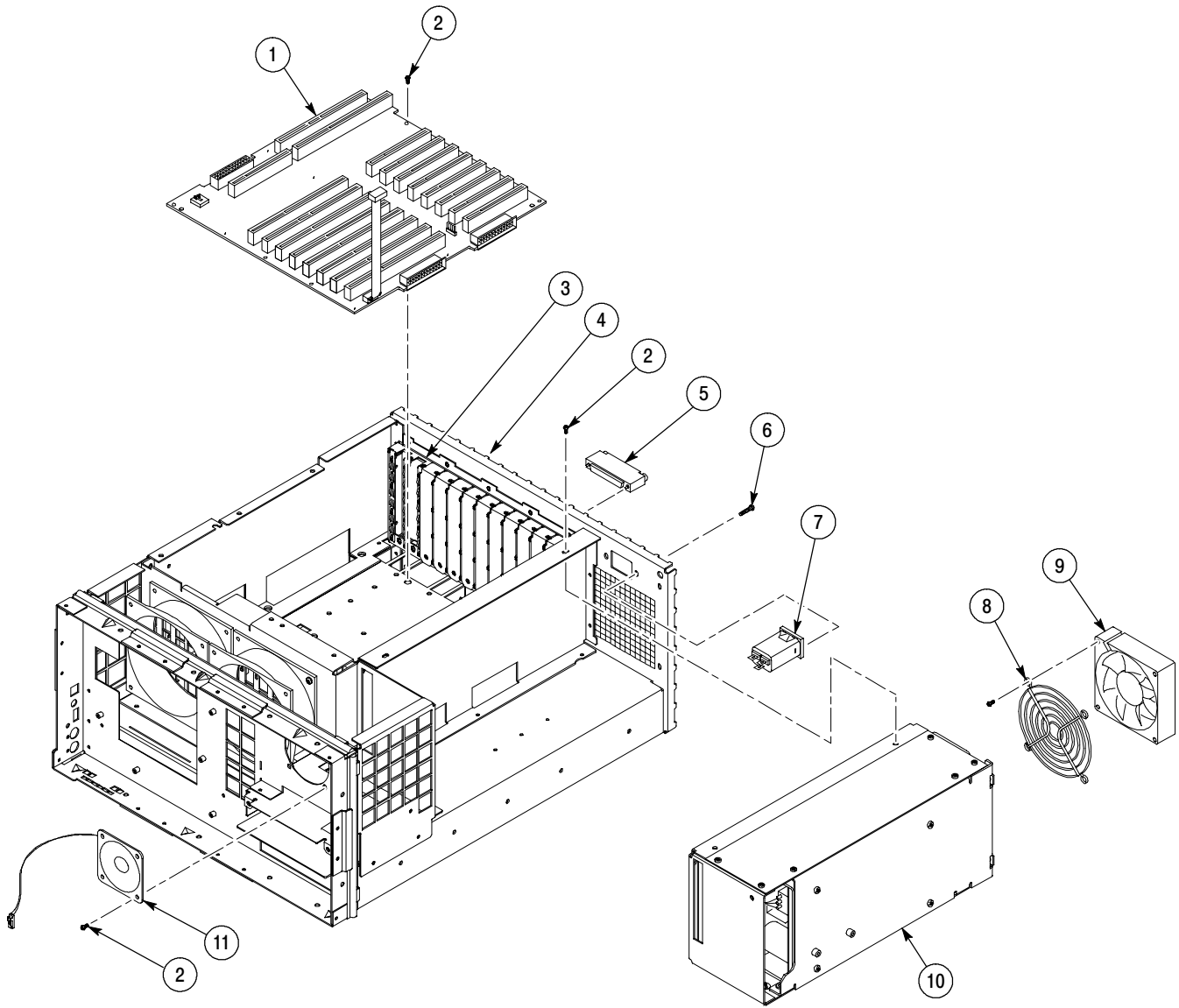


Figure 8- 1: Chassis parts

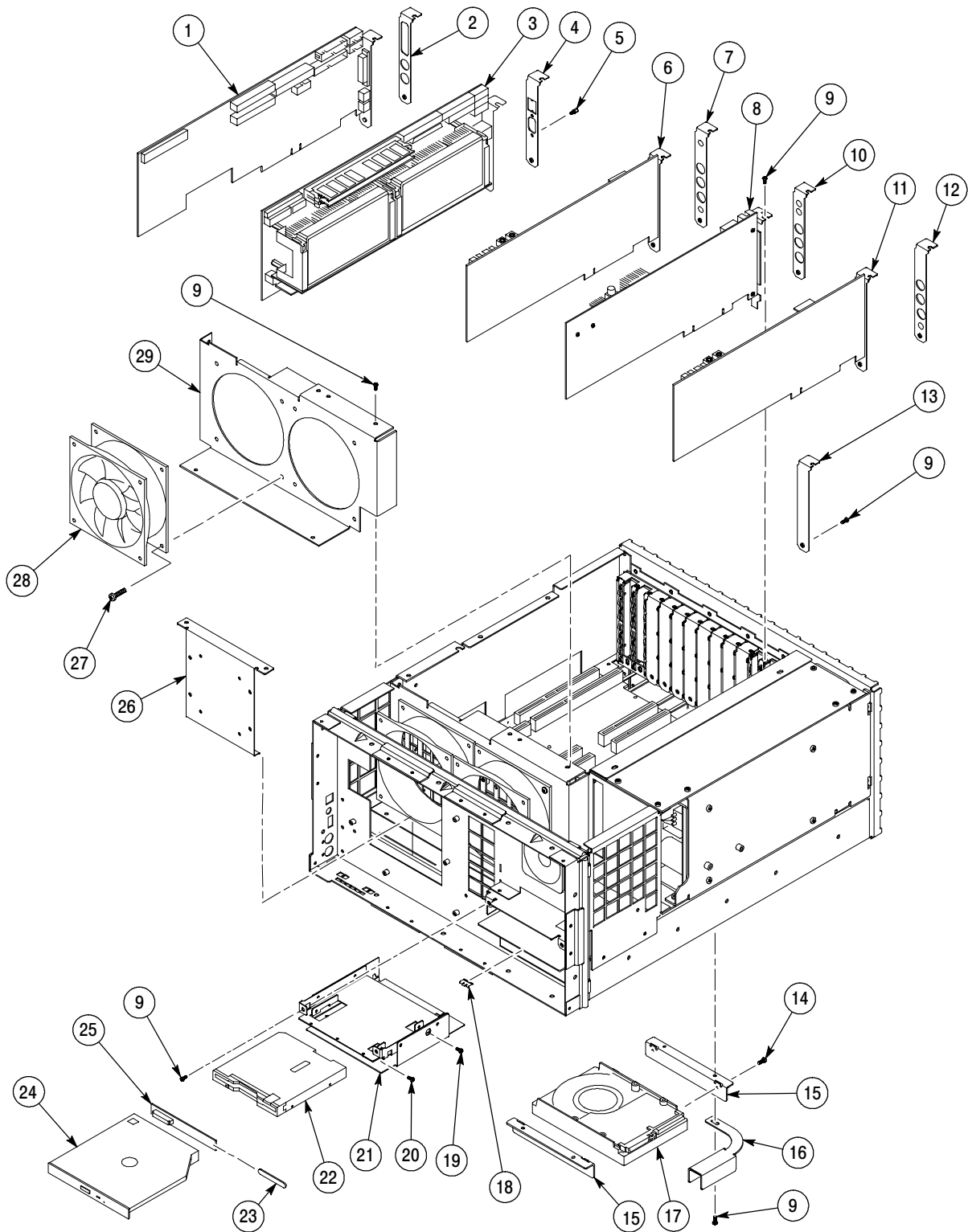
## Replaceable parts list

Fig. & index number	Tektronix part number	Serial no. effective	Serial no. discont'd	Qty	Name & description	Mfr. code	Mfr. part number
8-2							
1	671-4793-00			1	CIRCUIT BD ASSY: PROCESSOR. IO	80009	671-4793-00
2	407-4699-00			1	BRACKET PCI PROCESSOR I/O BOARD. 18 GA CRS	TK1943	407-4699-00
3	672-1551-01			1	CIRCUIT BD ASSY: PICMG PCI. CONTROLLER	80009	672-1551-01
4	407-4705-00			1	BRACKET. PCI: 18 GA CRS. DTI PROCESSOR	TK1943	407-4705-00
5	131-0890-01			2	CONN. HARDWARE: DSUB. JACK SCREW. 4-40 X 0.312 L HEX HD. STL CD PL. W/O WASHERS & NUT	00779	205818-2
6	671-5392-50			1	CIRCUIT BD ASSY:ENCODER, PQA300	80009	671-5392-50
7	407-4813-00			1	BRACKET,REAR PANEL MOUNT,ENCODER	TK1943	407-4813-00
8	671-4797-00			1	CIRCUIT BD ASSY:DSP, PQA300	80009	671-4797-00
9	211-0722-00				SCREW. MACHINE: 6-32 X 0.25. 0PN. HST. LCDP. LT-15 TORX DR	0KB01	ORDER BY DESCRIPTION
10	407-4716-00			1	BRACKET,REAR PANEL MOUNT,DSP	TK1943	407-4716-00
11	671-5390-50			1	CIRCUIT BD ASS:DECODER, PQA300	TK1943	671-5390-50
12	407-4752-00			1	BRACKET: REAR PANEL MOUNT, DECODER	TK1943	407-4752-00
13	407-4715-00			4	BRACKET: 0.062 AL. SIDE MOUNTING. 5.0L X 0.750. ETCH/CHROMATE	TK1943	407-4715-00
14	211-0747-00			8	SCREW. MACHINE: 6-32 X 0.188. PNH. STL. CDPL. T-15 TORX DR	0KB01	ORDER BY DESCRIPTION
15	407-4710-01			4	BRACKET: SCSI DRIVE MTG. 15.580 X 10.250. 0.062AL. CHROMATE	5Y400	407-4710-01
16	407-4841-00			1	BRACKET,HARD DRIVE:CABLE RETAINER,0.050 AL	TK1943	441-4841-00
17	119-6175-00		B010118	1	DISK DRIVE:WINCHESTER,3.5 INCH, 9 GBYTE, SCSI, 25L1810	9F560	25L1810
	119-6175-01	B010119		1	DISK DRIVE:WINCHESTER,3.5 INCH, 9.1 GBYTE, SCSI, 07N3220	9F560	07N3220
18	348-1567-00			6	GASKET. ELEC: CLIP ON. 16 X 0.51. BE CU. BRIGHT NI PLT	TK2647	97-521-19
19	211-1079-00			3	SCREW. MACHINE: 2.6 X 0.45 MM. 3.0L. PNH. STL. NICKEL PL. PHILLIPS. JCIS	0KB01	10310188-0
20	211-0950-00		B010107	4	SCREW. MACHINE: M2X3MM. PHL. PNH. STL NI PL	0KB01	0310248-0
	211-1070-00	B010108		4	SCREW. MACHINE: M2X2MM. PHL. PNH. STL NI PL	0KB01	211-1070-00
21	407-4721-02			1	BRACKET ASSY: DRIVE MOUNTING. 0.040 AL. ALLOY 5052 H32. ETCH/CHROMATE	TK1943	407-4721-02
22	119-6106-00			1	DISK DRIVE: FLOPPY. 3.5INCH. 1.44 MB. 0.5 IN HIGH. BLACK BEZEL. DDDS. 96 X 126 X 12.7MM. FD-05HF563	TK2250	FD-05HF5630
23	348-1432-00			1	FOOT: 6.5MM W X 43.50MM L. 2MM THK. RUBBER. BLACK. INSTRUMENT SUPPORT	TK2411	348-1432-00
24	119-5728-01			1	DISK DRIVE: OPTICAL. 644MB. CD-ROM. 16.7 MB/SEC. IDE/ATAPI. CD-224E-93.	50356	CD-224E-B93
25	671-4377-00			1	CIRCUIT BD ASSY: CD ROM INTERFACE. 389-2561-00 WIRED	80009	671-4377-00

**Replaceable parts list (Cont.)**

<b>Fig. &amp; index number</b>	<b>Tektronix part number</b>	<b>Serial no. effective</b>	<b>Serial no. discount'd</b>	<b>Qty</b>	<b>Name &amp; description</b>	<b>Mfr. code</b>	<b>Mfr. part number</b>
26	407-4515-01			1	BRACKET: HARD DRIVE MTG. 0.040 ALUMINUM. ALLLOY 5052 H34.	TK1943	407-4515-00
27	211-0721-00			2	SCREW. MACHINE: 6-32 X 0.375. PNH. STL. CDPL. T-15 TORX DR	0KB01	ORDER BY DESCRIPTION
28	119-5695-00			2	FAN. DC: TUBEAXIAL. 12 V. 3.24W. 2300 RPM. 83 CFM. 119MM X 38MM. 35 DBA. W/2 PIN CONNECTOR.	TK1943	NMB 4715KL-04W-B10-P00
29	407-4700-00			1	BRACKET ASSY: FAN MOUNTING.	TK1943	407-4700-00

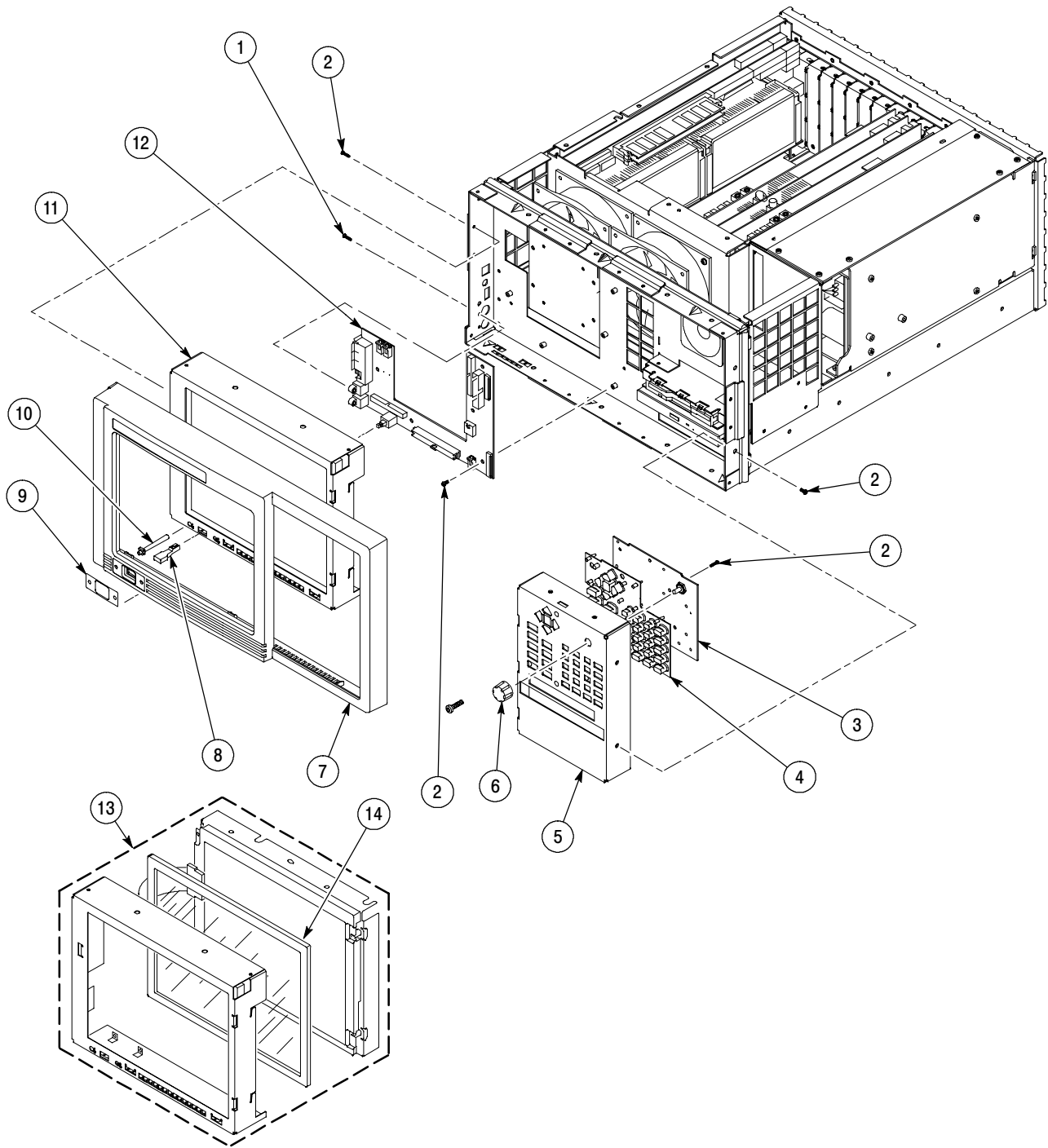




**Figure 8-2: Modules and mounting hardware**

**Replaceable parts list**

Fig. & index number	Tektronix part number	Serial no. effective	Serial no. discont'd	Qty	Name & description	Mfr. code	Mfr. part number
8-3							
1	211-0895-00			2	SCREW. MACH: M2.6 X 0.45 X 8MM. PHILLIPS. PNH. ZINC YELLOW	0KB01	211-0895-00
2	211-0722-00			80	SCREW. MACHINE: 6-32 X 0.250. PNH. STL. CDPL. T-15 TORX DR	0KB01	ORDER BY DESCRIPTION
3	679-4125-01			1	CIRCUIT BD ASSY: KEYPAD. TESTED. WIRED	80009	671-4125-01
4	260-2691-00			1	SWITCH,KEYPAD:ELASTOMECH,TV GRAY & TRANSLUCENT,RESISTANCE>1000OHMS,JAMAICA	TK2376	260-2691-00
5	614-0943-01			1	KEYPAD ASSY:RFA300	80009	614-0943-01
6	366-0790-00			1	KNOB:TV GRAY,0.920 ID X 0.9250 OD X 0.4750 H,PC/ABS BAYBLEND FR110	TK1163	366-0790-00
7	200-4384-00			1	BEZEL:PC ABS,9 X 17 X 1.50,JAMAICA,	TK2385	JAMACIA FRONT TRIM,HOUSING
8	366-0791-00			1	KEYCAP: POWER. 0.2X0.4X1.326. POLYCARBONATE.	7X318	366-0791-00
9	334-9582-00			1	MARKER. IDENT: LABEL. POWER BUTTON. 2.000 X 0.735	0KB05	334-9582-00
10	352-1068-00			2	LENS. LIGHT: CLEAR. ACRYLIC. LIGHT PIPE. 1.729 X 0.140	7X318	352-1068-00
11	407-4074-00			1	BRACKET: DISPLAY ASSEMBLY	TK1943	407-4704-00
12	679-4952-00			1	CIRCUIT BD ASSY: INTERFACE	80009	671-4952-00
13	650-4004-01			1	DISPLAY ASSEMBLY (OPT LC)	80009	650-4004-01
14	119-5934-00			1	TOUCH SCREEN:TOUCH PANEL ASSEMBLY 8-WIRE ANALOG RESISTIVE,10.4 INCH DISPLAY (OPT LC)	TK6074	9504 REV G



**Figure 8-3: Front panel parts**

**Replaceable parts list**

Fig. & index number	Tektronix part number	Serial no. effective	Serial no. discount'd	Qty	Name & description	Mfr. code	Mfr. part number
8-4							
1	343-1652-00			1	RETAINER: CIRCUIT BOARD	TK1943	343-1652-00
2	174-4229-00			1	CABLE ASSEMBLY: PARALLEL PORT. 2.500 INCHES	060D9	174-4229-00
3	174-4226-00			1	CABLE ASSEMBLY: PARALLEL PORT. 2 X 13. 2.500 INCHES	060D9	174-4226-00
4	174-4227-00			1	CABLE ASSEMBLY: FLOPPY. 2 X 17. 2.500 INCHES	060D9	174-4227-00
5	174-4225-00			2	CABLE ASSEMBLY: KEYBOARD/MOUSE. COM1. 2 X 5. 3.850 INCHES	060D9	174-4225-00
6	174-3940-00			1	CA ASSY,RF:COAXIAL,RFD,1,75 OHM, RG179,DOUBLE SHIELDED,10.0 L	060D9	174-3940-00
7	174-3939-00			1	CA ASSY,RF:COAXIAL,RFD,1,75 OHM, RG179,DOUBLE SHIELDED,12.5 L	060D9	174-3939-00
8	174-3761-00			1	CA ASSY. SP: RIBBON. RS232. IDC. 9. 3.5 L END TO END. (DSUB. MALE. RTANG. 9 POS. 0.109 CTR. W/THD INSER	060D9	174-3761-00
9	131-0890-01			2	CONN. HARDWARE: DSUB. JACK SCREW. 4-40 X 0.312 L HEX HD. STL CD PL. W/2 FLAT WASHERS. 1 LOCK WASHER. 4	0KB01	131-0890-01
10	174-4260-00			1	CA ASSY: DESCRETE. SCSI POWER. 16AWG. 19.5L. 2 DRIVE VERSION	060D9	174-4260-00
11	343-0775-00			2	CABLE. CLAMP: RIBBON. 1.0 X 1.0. GRAY. POLYVINYL. W/URETHANE FOAM TAPE BACKING. RETAINS 6 RIBBON CABLES	52152	80610029243/3484-1000
12	174-4261-00			1	CA ASSY: SCSI CONTROL. SCSI 68POS MALE X 3. SCSI 68 POS FEMALE PANEL MOUNT	060D9	174-4261-00
13	174-3786-01			1	CA ASSY. SP. LEC: HIGH DENSITY. FLOPPY DRIVE. ZIF. 6. .039 CTR. IN PLATED END FOR ZIF-LINE CONNECTOR	060D9	174-3786-01
14	174-4223-00			1	CABLE ASSEMBLY: FRONT PANEL INTERFACE. 2 X 50. 15.0 INCHES	060D9	174-4223-00
15	174-3814-00			1	CA ASSY. SP. ELEC: RIBBON. IDC. 4. 26-30 AWG. 15.0 L. (FEMALE. STR. 2 X 2. 0.079 CTR (2MM). BERG 69307-004)	060D9	174-3814-00
16	174-3787-00			1	CA ASSY. SP. ELEC: RIBBON. DISPLAY ADAPTOR BOARD. FLX. 50. 28AWG. 6.5 L. (RCPT. 2 X 50. FEMALE. STR. 0.079 C	060D9	174-3787-00
17	174-3789-00			1	CA ASSY. SP. ELEC: RIBBON. FRT PNL POWER. IDC. 30. 28AWG. PVC. 3 FOLDS (2.25 L. 8.5 L. 5.5L. 2.5L). (RCPT. F	060D9	174-3789-00
18	174-4237-00			1	CA ASSY: SP. BR. RIBBON. USB/SPEAKER. 26 AWG. 1 X 6 0.1 CTR X 2 - 1 X 4 0 .1 CTR	060D9	174-4237-00
19	174-4224-00			1	CABLE ASSEMBLY: IDE TO CD ROM. 11.200 X 10.400 X 6.800 X 2.850	060D9	174-4224-00
20	174-4262-00			1	CA ASSY: RIBBON. SCSI LED. 26 AWG. 6.500L. 2X BERG P/N 65039-35	060D9	174-4262-00
21	211-0722-00			7	SCREW. MACHINE: 6-32 X 0.250. PNH. STL. CDPL. T-15 TORX DR	0KB01	ORDER BY DESCRIPTION

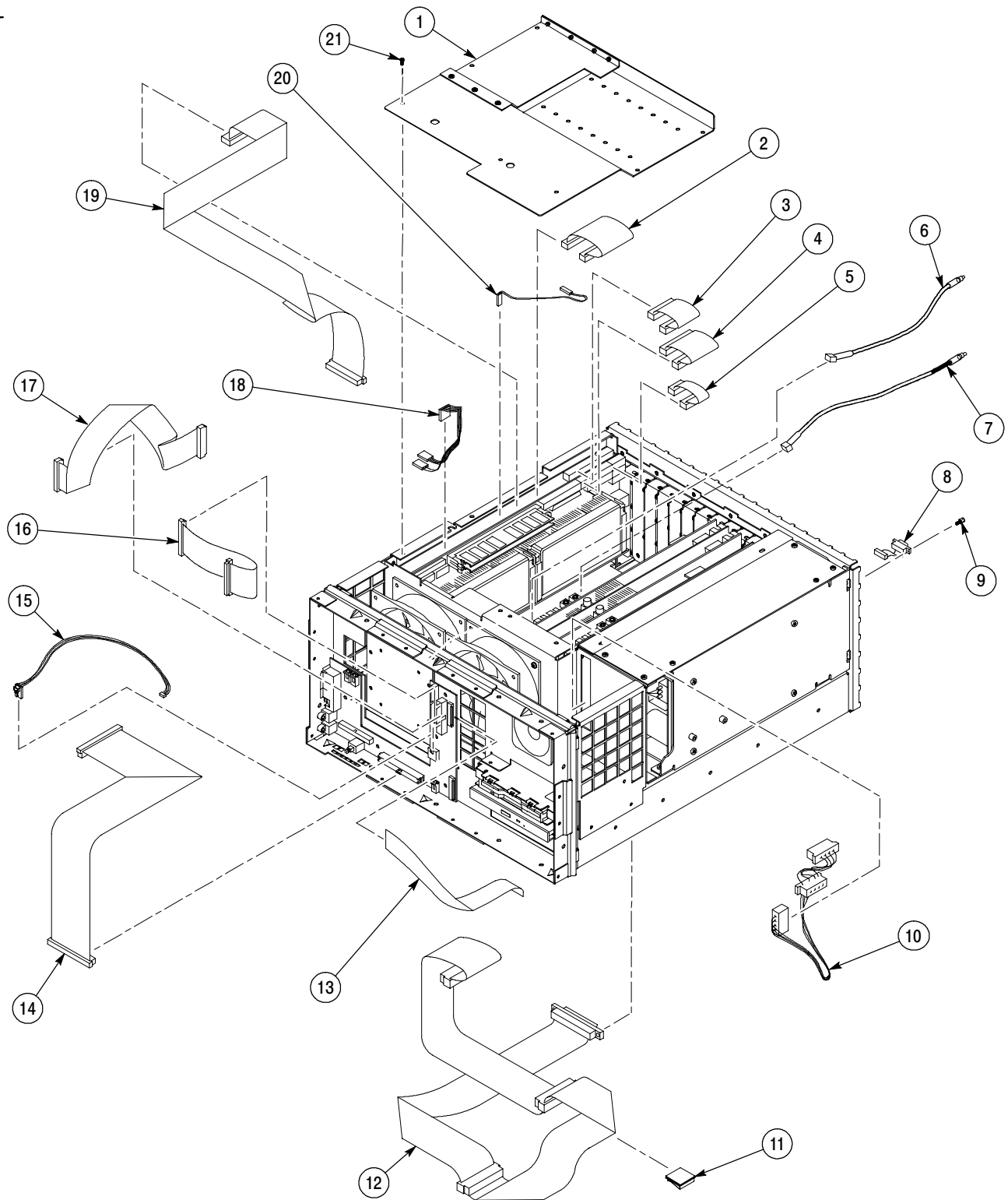


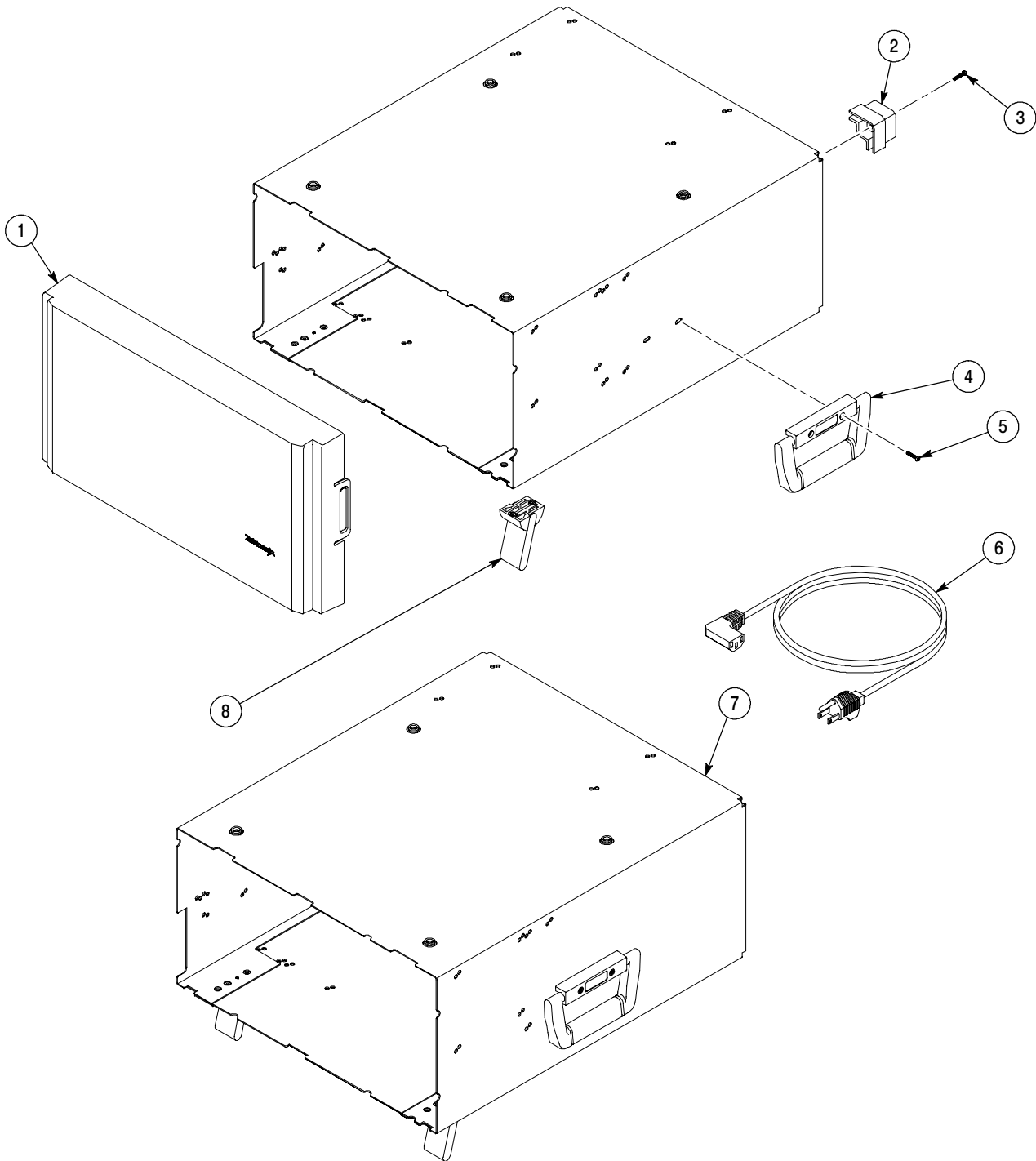
Figure 8-4: Cables

**Replaceable parts list**

Fig. & index number	Tektronix part number	Serial no. effective	Serial no. discont'd	Qty	Name & description	Mfr. code	Mfr. part number
8-5							
1	200-4408-00			1	COVER:PROTECTIVE	TK2480	200-4408-00
2	348-1154-01			4	FOOT,CABINET	80009	348-1154-01
3	211-0738-00			4	SCREW,MACHINE:6-32 X 0.625,PNH,STL BLK ZI,TORX	93907	ORDER BY DESCRIPTION
4	367-0477-00			1	HANDLE,CARRYING	12136	PT 3170
5	212-0213-00			2	SCREW,MACHINE:8-32 X 0.75 L,PNH,STL, BLACK OXIDE PL,TORX	0KB01	212-0213-00
6	161-0066-00			1	CA ASSY,PWR:3,18 AWG,250V/10A,98 INCH,US	0B445	ECM-161-0066-00
7	390-1176-00			1	CABINET:WRAP AROUND,W/HANDLE AND FEET	TK1943	390-1176-00
8	348-1515-00			2	FOOT, CABINET	TK1943	348-1515-00
<b>STANDARD ACCESSORIES</b>							
	071-0909-00			1	MANUAL,TECH:USER,PQA300 PICTURE QUALITY ANALYSIS	TK2548	071-0909-00
	063-3477-00			1	SOFTWARE PKG:APPLICATION,PICTURE QUALITY ANALYSIS,PQA300	TK2548	063-3477-00
	063-3484-00			1	SOFTWARE PKG:OPERATING SYSTEMS RECOVERY CD,PQA300	TK2548	063-3484-00
	016-1691-01			1	RACKMOUNT KIT:W/075-0372-01 INSTRUCTION SHEET,JAMAICA PLATFORM,		016-1691-01
	161-0066-00			1	CA ASSY, PWR: 3,18 AWG, 250V/10A, 98 INCH, STR, IEC320, RCPT X NEMA 5-15P, US, SAFETY CONTROLLED	0B445	ECM-161-0066-00
	063-3483-00			1	SOFTWARE PKG:VIDEO TEST SEQUENCES,PQA300	TK2548	063-3483-00
	012-0159-01			1	CA ASSY, RF: COAXIAL, LOW LOSS; RFD, 75 OHM, DUAL SHIELD, (2) TINNED COPPER, 72 L, BNC, MALE, STR, BOTH ENDS, CRIMP	060D9	012-0159-01
<b>STANDARD ACCESSORIES FOR OPTION 01</b>							
	174-3916-00			2	CA ASSY,RF:COAXIAL,RFD,1,75 OHM,9.0 L, BNC PLUG X SMB JACK (OPT 01)	80009	174-3916-00
	174-3915-00			1	CA ASSY, RF: COAXIAL, RFD, 1, 8.0 L, 75 OHM , SMB JACK BOTH ENDS (OPT 01)	80009	174-3915-00
	011-0102-01			2	TERMINATION, COAXIAL: 75 OHM, BNC (OPT 01)	80009	011-0102-01
	012-1554-00			2	CABLE,RF: COAXIAL, SVHS CABLE, 4, 75 OHM, DUL COAX, 72.0 L (6 FT),(MINI-DIN,4 POS,MALE,STR,GOLD (OPT 01)	TK6159	012-1554-00

## Replaceable parts list (cont.)

Fig. & index number	Tektronix part number	Serial no. effective	Serial no. discont'd	Qty	Name & description	Mfr. code	Mfr. part number
<b>STANDARD ACCESSORIES FOR OPTION LC</b>							
	118-9402-00			1	ASSY:83 KKEYBOARD EY NOTEBOOK KEYBOARD,IBM AT OR PS/2 COMPATIBLE,GRAY	01963	684-4100PAU
	119-4330-02			1	POINTER ASSY:MOUSE,400 DPI MOUSE,LOGITECH,SAW35,	46628	850448-0001
	119-6107-00			2	STYLUS:STYLUS FOR TOUCH SCREEN	03ZT7	T1100
<b>OPTIONAL ACCESSORIES</b>							
	161-0066-09			1	CA ASSY,PWR:3,0.75MM SQ,250V/10A,99 INCH,STR,IEC320,RCPT,EUROPEAN (EUROPEAN OPTION A1 ONLY)	2W733	ORDER BY DESCR
	161-0066-10			1	CA ASSY,PWR:3,0.1MM SQ,250V/10A,2.5 METER,STR, IEC320,RCPT X 13A,FUSED UK PLUG(13A FUSE),UNIT (UNITED KINGDOM OPTION A2 ONLY)	TK2541	ORDER BY DESCR
	161-0066-11			1	CA ASSY,PWR:3,1.0MM SQ,250V/10A,2.5 METER,STR, IEC320,RCPT,AUSTRALIA (AUSTRALIA OPTION A3 ONLY)	80126	ORDER BY DESCR
	161-0154-00			1	CA ASSY,PWR:3,1.0MM SQ,250V/10A,2.5 METER,STR, IEC320,RCPT,SWISS (SWISS OPTION A5 ONLY)	5F520	86515030
	161-0304-00			1	CA ASSY,PWR:3,1.0MM SQ,250V/10A,2.5 METER,STR,IEC320,RCPT,CHINA, (CHINA OPTION AC ONLY)	0B445	E13.900.098.A01
	071-0914-00			1	MANUAL,TECH:SERVICE,PQA300 PICTURE QUALITY ANALYSIS SYSTEM	TK2548	071-0914-00



**Figure 8- 5: Cabinet parts and accessories**





# Appendices



# Appendix A: Software Repair

The information in this appendix explains how to create and use an Emergency Repair Disk, gives instructions on reloading the PQA300 software, and how to load the video test sequences.

## If an Application Locks

As with all software, the application may lock up. In most cases the best solution is to use the Windows NT End Task utility. The following procedure uses this utility to unlock the application.

1. Press Ctrl+Alt+Del to access the Windows NT Security dialog box.
2. Choose the Task List command button to bring up the Task List dialog box.
3. Click on the locked application.
4. Click on the End Task command button. This should close the locked application.

If this does not close the locked application, perform the following procedure:

1. Press Ctrl+Alt+Del to access the Windows NT Security dialog box.
2. Choose the Shutdown command button to bring up the Shutdown dialog box.
3. Choose the Shutdown and Restart option button and then choose OK.

If this does not end the application or shut down the unit, power the instrument down for a few minutes, and then proceed with a normal power up.

---

**NOTE.** *It is not good practice to power down the instrument without first exiting Windows NT. Use this method only if the instrument is not responsive.*

---

## Creating and Using an Emergency Repair Disk

An emergency repair disk, specific to the system, is supplied with each PQA300 analyzer. Whenever you upgrade the software or change your password, it is strongly recommended that you also create a new emergency repair disk. This will minimize the chances that you will need to completely reload the operating software for a minor problem.

Use the emergency repair disk to restore your system to its initial setup state if your system files become corrupt and you are unable to recover the previous start-up configuration (Last Known Good - the Windows NT startup screen option). If you don't have the emergency repair disk, you will have to reinstall Windows NT. Refer to the Windows NT System Guide for the procedure required to restore your system.

You may also need the emergency repair disk to restore user passwords if they are forgotten. Be sure to update the emergency repair disk each time you add a user or change a password.



---

**CAUTION.** *The files on the Emergency Repair Disk are PQA300-specific; that is, the disk shipped with an PQA300 is the ONLY one that will work with that unit. Do not lose this disk. If you lose the Emergency Repair Disk provided with your PQA300, create a new one as described below.*

---

### Creating an Emergency Repair Disk

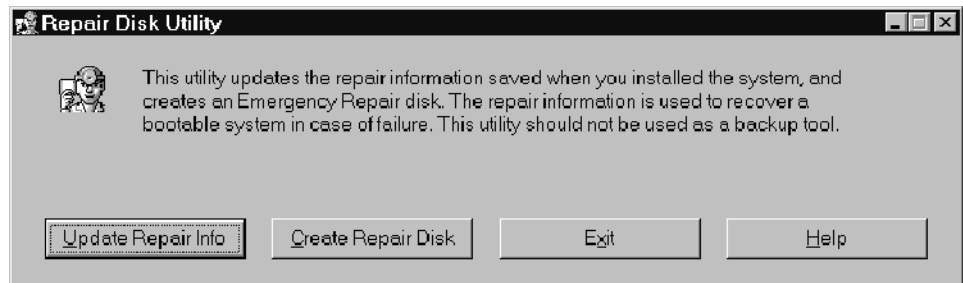
To create an emergency repair disk, mark a High Density 3.5-inch disk clearly as the emergency repair disk for PQA300 serial number B0xxxxx and then perform the following steps:

---

**NOTE.** *The emergency repair disk is PQA300-specific. Make sure that the emergency repair disk is clearly marked with its PQA300 serial number. The serial number of your PQA300 analyzer appears on the original emergency repair disk and on the instrument rear panel.*

---

1. Choose Run from the Windows NT Start menu.
2. Type rdisk in the Run dialog box. The Repair Disk Utility dialog box, as shown below, opens.



3. Click Update Repair Info to save your current configuration. A message appears to remind you that earlier repair information is overwritten. Click Yes to continue.
4. When the process is complete, a message appears to ask if you wish to create an Emergency Repair Disk. Click Yes. The message shown below appears.



5. Insert a 3.5-inch disk in drive A and click OK. Rdisk formats the disk and copies the configuration files onto it.
6. When the operation is complete, click Exit in the Repair Disk Utility dialog box. Remove the disk from drive A and keep it in a safe place.

### Using the Emergency Repair Disk

Always refer to the Windows NT documentation if you need more information.

1. Verify that you have a source of setup information available (the Windows NT back up software package).
2. Insert the Windows NT Setup disk.
3. Restart the PQA300.
4. When the Windows NT Setup Screen appears, press R (repair).
5. When prompted, insert the emergency repair disk.
6. The emergency repair disk performs the following:
  - Runs CHKDSK.EXE on the WINNT and SYSTEM partitions.
  - Verifies each file in the installation and replaces any that are missing or corrupt.
  - Replaces the System, Security, and Security Accounts Manager hives in the registry.
  - Reinstalls the Boot Loader (the boot sector, BOOT.INI, etc.).

## Reinstalling the PQA300 Picture Quality Analysis System Software

Use the following procedures to reinstall your PQA300 software if it is accidentally deleted or becomes corrupted. The application software is supplied on CD-ROM.

---

**NOTE.** *The following instructions are for reinstalling the PQA300 application software on a machine running Windows NT Workstation 4.0 only; procedures for upgrading the software may be different. If you are installing a software upgrade, follow the instructions provided with the upgrade kit.*

---

### Installing the PQA300 Application Program

Reinstalling the software involves the following procedures:

1. Place the software install disk in the CD player.
2. The Install Wizard displays.
3. Select either a full installation or a restoration of selected files, depending on the instrument condition.

### Standard Instrument Encoder and Decoder Driver

The PQA300 application software supports both the standard instrument and the Option 01 instrument, but when reloaded into the instrument, it is automatically set up for Option 01. In the standard instrument without the encoder and decoder circuit boards, the device driver for those boards must be disabled to prevent an error message about the modules not being installed. If the error message appears when starting the PQA300 application, click OK to continue. Turning off the driver stops the message from appearing.

Use the following procedure to turn off the encoder and decoder device driver in the standard instrument.

1. In the Windows NT screen, use the Start button in the task bar to select the Windows NT Control Panel (Start, Settings, Control Panel).
2. In the Control Panel, click on Devices two times quickly to open the device drivers control menu.
3. Scroll down the list of device drivers to the PQA Encoder/Decoder Driver and select it.
4. On the right side of the drivers list, select Disabled and close the window.
5. Close the Control Panel window.

When you start the PQA300 application with Version 2.0 firmware in a standard instrument, the error message about no encoder and decoder modules being installed will not be displayed with the device driver disabled.

## Installing the Generator and Reference Sequences

The test sequences are supplied on CD-ROM disks in Header Only and Header Plus generator sequences. The reference sequences are extracted from the generator sequences in the installation process. During installation, you have to select which generator sequences and reference you want to install.

1. Place the disk containing the sequences you want to install in the CD drive.
2. As with the Application Program disk, the CD reads automatically and the Install Wizard displays. The first installation window shows the standard warning that you should close any programs you have running, and it shows the copyright warning. Click on Next to continue the installation procedure.



3. The second window shows the default destination folder where the files you select later are to be saved. The default for normal installation of the files is the D drive in the PQA300 directory. If that selection is appropriate for your system, click on Next to continue the installation, and skip to step 5.



4. Click the Browse soft key to select other destinations for the files including any network drives that are accessible. After you make your selection, click the OK button to accept the change and exit the menu.

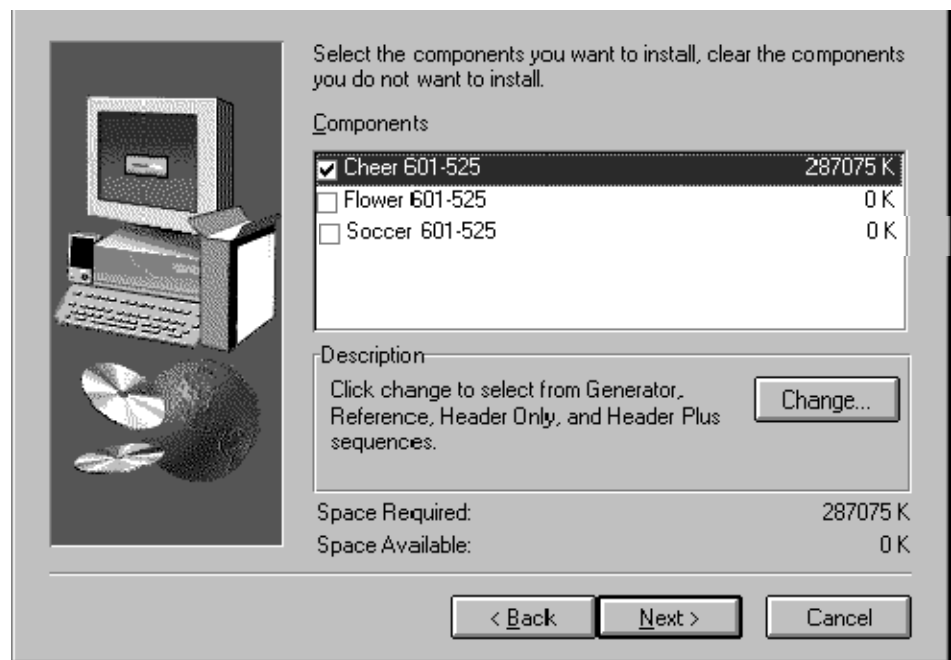


5. Click the Next button to continue the process. The next window is the selection window for choosing the test sequence or sequences you want to store on the hard drive.

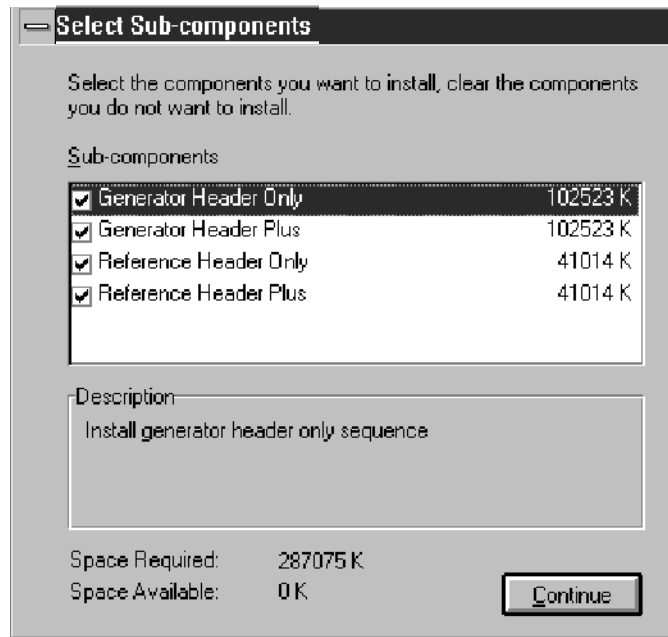


- Click in the check box to select a test sequence for installation. At this point all of the sub-components of the selected test sequence (generator, generator plus, reference, and reference plus) are selected for installation.

**NOTE.** The selections available under the Change soft key apply only to the highlighted test sequence name. If you want to make change selections for another sequence, highlight the sequence name before you click on the Change soft key.



- If you do not want to install all of the sub-components of a test sequence, click on the Change soft key. If you want to store all the sub-components, go to step 10.
- The window displayed when Change is selected permits you to clear any of the sub-components of a test sequence you do not want to install. Click in the check box to deselect any part of the test sequence. Note that if you deselect them all, the main test sequence selection also becomes deselected.
- Click on the Continue soft key to continue the installation after you have completed the sub-component selections.



10. The amount of disk space needed to store the selected test sequence components is displayed along with the amount of space available. If there is not enough disk storage space available, you will get a message to that effect, with a suggestion to either make more disk space or modify your selection to reduce the storage space required. You can delete unneeded generator and reference sequences using the Windows NT file manager or the PQA300 file operations menu. Generator video sequences are about 102 Mbytes each, and reference video sequences are about 42 Mbytes each.
11. Click Next to begin installing the files. A list of all the files you have selected for installation is displayed. If those selections are not what you want, go back to step 8 to correct the selection list. If the list is correct, click on the Continue soft key to install the files.

The generator and reference files you selected are automatically stored in the correct folders in the PQA300 directory (generator and reference respectively).

## Appendix B: PQA300 Directories and Files

The application software for the PQA300 consists of a number of directories and files. Note that nine directories are installed on the system drive (d:\) and the application files are loaded into these directories. The path is provided for each directory and file.

Path: D:\PQA300

\bin	<Dir>
\capture	<Dir>
\encdec	<Dir>
\function	<Dir>
\generate	<Dir>
\log	<Dir>
\precompute	<Dir>
\preference	<Dir>
\reference	<Dir>
\results	<Dir>
\temp	<Dir>

Path: D:\PQA300\bin

\drivers	<Dir>
\fonts	<Dir>
\support	>Dir>
Mfc42.dll	An executable file extension.
mfc42.dll	An executable file extension.
msvcrt.dll	An executable file extension.
mfco42d.dll	An executable file extension.
msvcrt.d.dll	An executable file extension.
pqa300.exe	The PQA300 application executable file.
pqa300ip.exe	An application initialization executable file.
pqa300ui.cnt	The online help contents file.
pqa300ui.exe	The PQA300 user interface executable file.
pqa300ui.GID	A file generated by the online help system.
pqa300ui.hlp	The online help file.
tekseqs.map	A list of the Tektronix video test sequences recognized.
caprefs.map	A list of the user named captured references. The user named references map to the user named test sequences.
userseqs.map	A list of the user named captured test sequences.
startup.prf	The startup preference file.

Path:D\PQA300\bin\support

iptools.ZIP	
Mfc42.dll	An executable file extension.

mfc42.dll	An executable file extension.
mfc4o42.dll	An executable file extension.
mmcodecs.exe	The encoder and decoder diagnostics executable file.
msvcrt.dll	An executable file extension.
msvcrt.d.dll	An executable file extension.
testdsp.exe	The DSP diagnostics executable file.

**Path: D:\PQA300\capture**

Location of all the captured (.cap) test video sequences. A new capture file is saved to this directory every time a captured file is saved to hard disk. Each file will have a time stamp to show the date and time of capture as well as the captured test sequence name and format id.

**Path: D:\PQA300\encdec**

Location of all the supporting files for the encoder and decoder. These files are a set of files that control the operating mode of the encoder and decoder modules.

**Path: D:\PQA300\function**

Location of all the function files (.tcl) for running automated testing sequences. These files are the scripts needed to run functions. Several function files are provided from Tektronix; others are user-generated files.

**Path: D:\PQA300\generate**

Location of all the generate (.gen) test video sequences. These files are the Tektronix provided test sequence loaded to the hard drive from CD-ROM or from another networked source.

**Path: D:\PQA300\log**

Location of all the log files. The log files are a set of files that record the activity of the application. The normal activity is record in the log file. User interface errors are recorded in the uierr file.

**Path: D:\PQA300\precompute**

Location of files that are precomputed as part of the measure process. The precomputed files are held here until needed for the measurement.

**Path: D:\PQA300\preference**

Location of all the preference (setup) files (.prf). These files are a set of text files that contain the setup information for the configuration files. The factory preference file contains the factory configuration settings. The shutdown preference file contains the configuration settings that were in effect at the time the PQA300 application was normally exited. The other preference files are user generated and named configuration settings.

Recalling these configuration files and saving others is controlled in the Preference configuration menu.

**Path:** D:\PQA300\reference

Location of all the stored reference (.ref) video sequences. These files are the Tektronix provided reference sequences loaded to the hard drive from CD-ROM or from a another networked source. They may also be test sequences captured as a reference.

**Path:** D:\PQA300\results

Location of all the measurement results files (.plm), (.jlm), (.jcm). New results files are saved for each measurement done on a captured video test sequence. The results files for a designated measurement or set of measurements call be recalled for display using the Results Configuration menu selections.

**Path:** D:\PQA300\temp

Location of the temporary files generated during the application processes. These temporary files are cleared when the process that generates them has completed.



## Appendix C: Video Test Sequences

The video test sequences are provided on CD-ROM disk in 601-525 and 601-625 digital video formats. There are five disks for the 525 sequences and five disks for the 625 sequences. The disk contents and the characteristics of the video in the test sequences are shown in Table C-1 for 601-525 format and in Table C-2 for 602-625 format. Each of the files is provided as Header Only and Header Plus video test sequences for the generator. The analyzer references are extracted from the generator video sequences during loading.

**NOTE.** Sequence of the same name in 525 and 625 formats do not necessarily have exactly the same content. Though very similar, the test sequences were acquired at different times; they were not converted from one format to another.

**Table C- 1: Video test sequences for 601-525 format**

Disk number	File name	Sequence title	Characteristic	Motion	Source
1	Flower	Flower Garden	Color details, landscape	Slow Pan	CCIR 15
	Cheer	Cheerleaders	Fast complex sports, rich background	Sports	CCIR 39
	Kiel	Kiel Harbor 4	Luminance detail, landscape	Zoom	CCIR 26
2	Tempete	Tempete	Horizontal, vertical, luminance, color detail	Random motion	CCIR 44
	Susie	Susie	Skin tone, talking head	Slow	CCIR 16
	Tennis	Table tennis	Multiple random motion, sports	Pan	CCIR 29
3	Football1	Football1	Sports, busy, large objects	Rapid motion	CCIR 38
	Football2	Football2	Slowly milling people, sports	Slow moving objects	CCIR 38
	Ferris	Ferris Wheel	Luminance and color details	Fast, complex	CCIR 36
4	Diva	Diva	Titles on busy scene	Slow	CCIR 43
	Mobile	Mobile and Calendar	Random motion of objects	Slow	CCIR 30
	Shinjuku	Shinjuku	Horizontal and vertical detail	Slow pan	CCIR 37
5	Wool	Balls of wool	Moving colors	Medium	CCIR 27
	Popple	Popple	Moving colors	Pan, rotate	CCIR 28
	Lily	Lily Pond	Luminance resolution	Still	CCIR 1

**Table C-2: Video test sequences for 601-625 format**

Disk number	File name	Sequence title	Characteristic	Motion	Source
1	Flower	Flower Garden	Color details, landscape	Slow Pan	CCIR 15
	Soccer	Soccer	Sports action	Fast	RAI
	Kiel	Kiel Harbor 4	Luminance detail. landscape	Zoom	CCIR 26
2	Tempete	Tempete	Horizontal, vertical, luminance, color detail	Random motion	CCIR 44
	Susie	Susie	Skin tone, talking head	Slow	CCIR 16
	Tennis	Table tennis	Multiple random motion, sports	Pan	CCIR 29
3	Ski	Ski race	Sports, moving objects	Pan, zoom	RAI
	Auto	Auto race	Sports, moving objects	Fast	RAI
	BBC	BBC disc	Random movement	Circular	CCIR 23
4	Diva	Diva	Titles on busy scene	Slow	CCIR 43
	Mobile	Mobile and Calendar	Random motion of objects	Slow	CCIR 30
	Sailboat	Sailboat	Moving colors	Slow	CCIR 14
5	Wool	Balls of wool	Moving colors	Medium	CCIR 27
	Popple	Popple	Moving colors	Pan, rotate	CCIR 28
	Lily	Lily Pond	Luminance resolution	Still	CCIR 1

The impaired video test sequences are provided to check the functionality of the PQA300. The impaired test sequences are provided as Mobile Header Plus sampled at different bit rates. When they are measured, the reference used in all cases is the Mobile+ reference sequence as identified from the header ID of the captured test sequence.

**Table C-3: Impaired video test sequences disk**

Sequence format	Sequence title	Sample rate
601-525	Mobile3mbs+.601	3 Mbits/sec
601-525	Mobile6mbs+.601	6 Mbits/sec
601-525	Mobile9mbs+.601	9 Mbits/sec
601-625	Mobile3mbs+.601	3 Mbits/sec
601-625	Mobile6mbs+.601	6 Mbits/sec
601-625	Mobile9mbs+.601	9 Mbits/sec